



LEADING THE RECYCLING ECONOMY,
INNOVATIVE ENERGY- SAVING EMISSION REDUCTION!



CBM9 Series Miniature Circuit Breakers CBL/G9 Series Earth Leakages

CBM9: MCB (13mm, 1P, 1P+N, 2P, 3P, 3P+N, 4P)
CBL9: RCCB (26mm, 2P)
CBG9: RCBO (26mm, 1P+N)



 **Gold Supplier**  Trade Assurance
[Http://Smartelectrical.en.Alibaba.com](http://Smartelectrical.en.Alibaba.com)
Alibaba.com  **TrustPass**

intertek
Total Quality. Assured.

dun & bradstreet

www.Oldlang.cn



BUREAU VERITAS



Oldlang_sale@163.com



CBM9(13mm) Miniature Circuit Breakers CBL9(13mm) Earth Leakages

Gold Supplier  Trade Assurance
[Http://Smartelectrical.en.Alibaba.com](http://Smartelectrical.en.Alibaba.com)
Alibaba.com  Verified  TrustPass



Innovative Energy-Saving Emission Reduction
Leading The Recycling Economy

www.Oldlang.cn
Oldlang_sale@163.com

About Oldlang Smart Electrical

The company named Oldlang Smart Electrical, which is a modern technology enterprise, committed to innovating energy conservation and emission reduction and leading the circular economy. The products focus on the original, low carbon, energy saving, collecting data, remote control and other functions are the characteristics of Oldlang's Smart electrical products. To enable users to use energy safely, reliably and efficiently is the value idea of Oldlang Smart Electrical. Therefore, the intelligent energy management is not only the inevitable development of the times, but also the direction of the development of the intelligent electrical of Oldlang's. Oldlang Smart Electrical provide wisdom into the city, the intelligent household practical products, improve people's life, improve the earth's environment, insist on sustainable development has always been the belief of Oldlang Smart Electrical.

In Oldlang smart electrical, we are always advocating:

INNOVATIVE ENERGY-SAVING EMISSION REDUCTION  LEADING THE RECYCLING ECONOMY!





CBM9 Miniature Circuit Breakers CBL9 Earth Leakages (13mm)

How to read Circuit Breaker Markings and Symbols

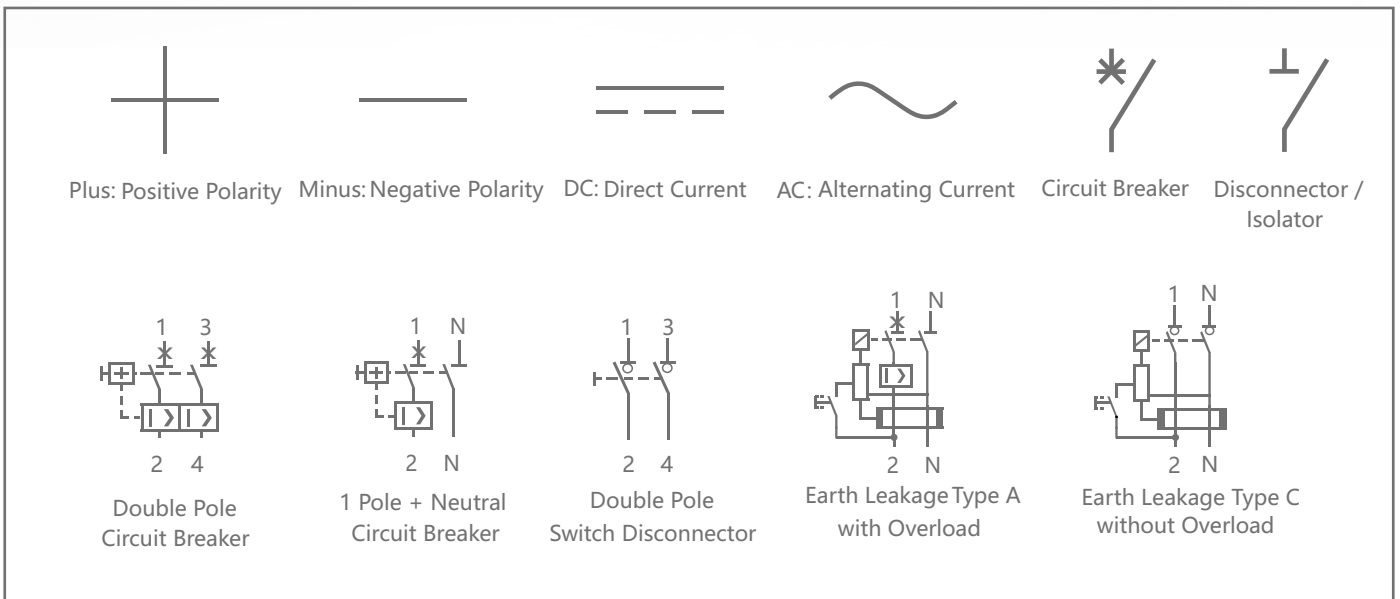
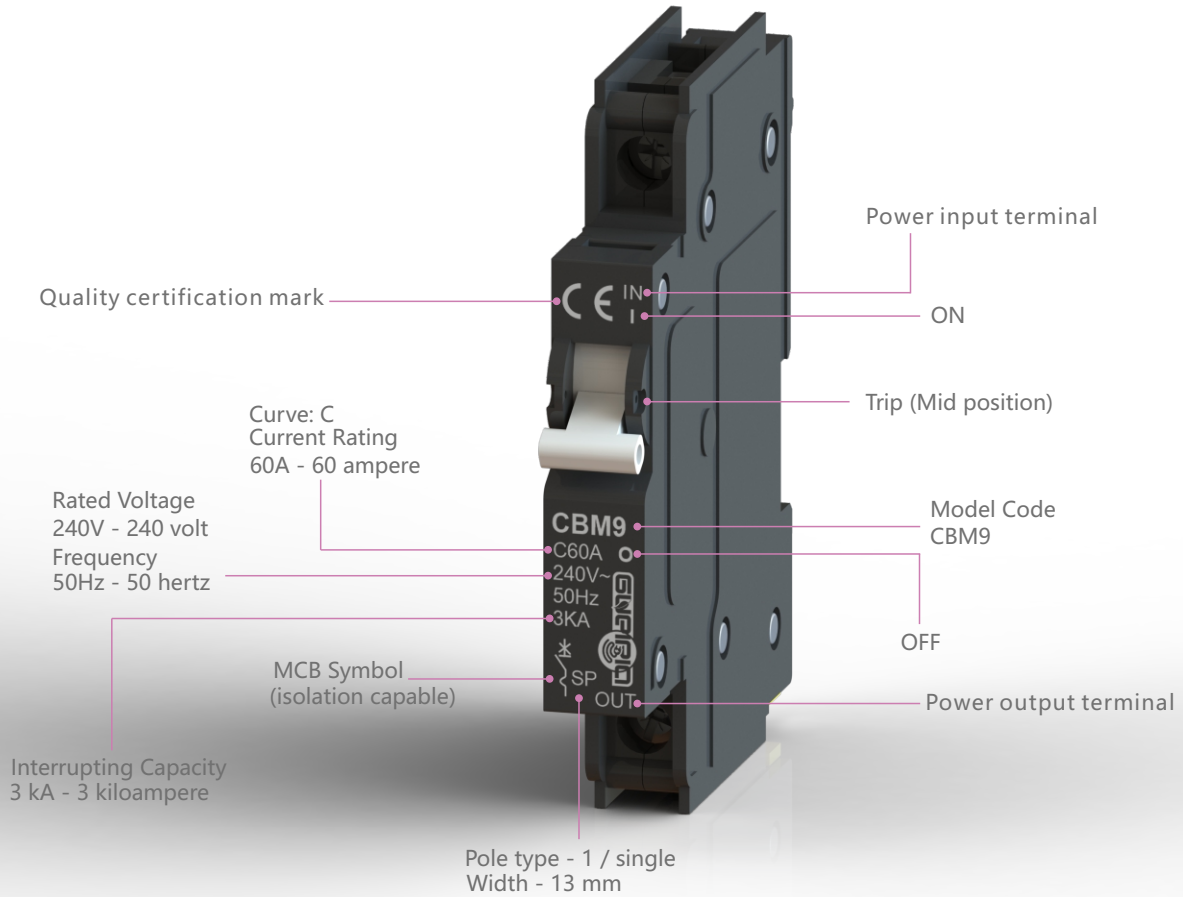



CBM9 (13mm) Miniature Circuit Breakers (MCB)

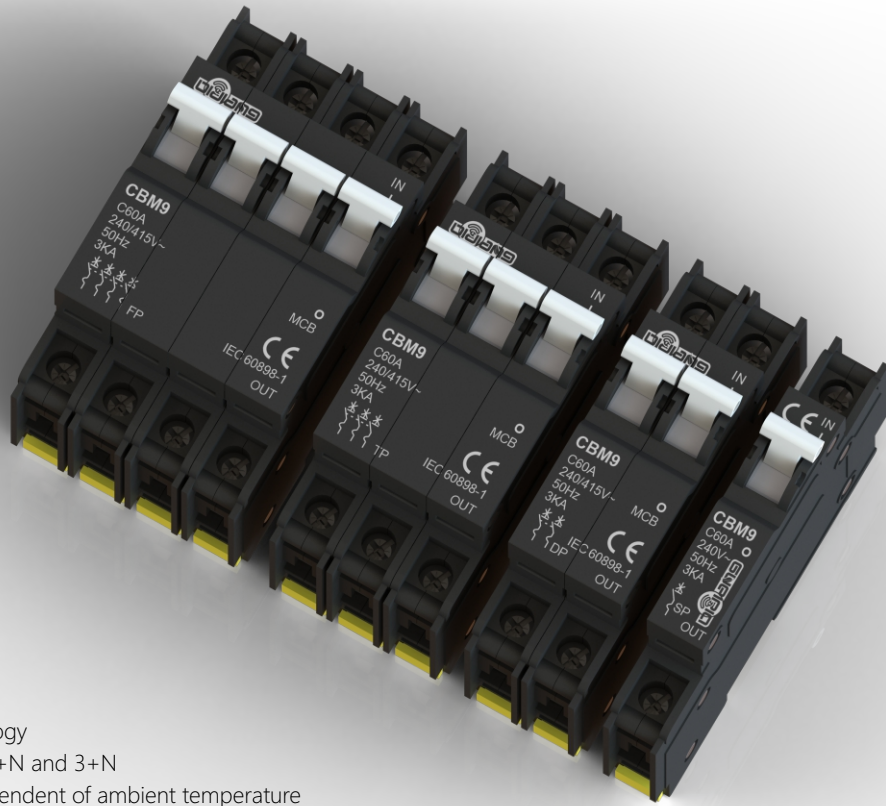

Features

- AC Circuit Breaker
- Hydraulic-Magnetic technology
- One, two, three, four pole, 1+N and 3+N
- 100% rating capability, independent of ambient temperature
- VC 8036 compliant (SANS 556-1)
- VDE approved, CE certiPed
- Ratings 5 to 60 A (subject to certiPcation)
- Precision tripping characteristics
- Ultra compact – 13 mm wide module
- Trip indication with mid-trip position
- Reset immediately after overload
- Mini Rail Mount product in black shells
- Suitable to use for electrical isolation
- Shell designed for easier installation onto busbar

Auxiliary Switch, Trip Alarm & Combo:

Features

- Auxiliary Switch
- Auxiliary Switch + Trip Alarm
- Trip Alarm
- AC and DC voltages
- UL 489 listed (Auxiliary Switch: 6 A 250 V AC, 0.5 A 80 V DC)
- IEC 60947-5-1 approved (Auxiliary Switch: 6 A 240 V AC, 0.5 A 110 V DC; Trip Alarm: 6 A 240 V AC, 0.5 A 110 V DC)
- Factory Ptted
- Attached to right hand side of Circuit Breaker
- Compact 6.5 mm width

Applications

- AC branch circuit protection (IEC / EN 60947-2)
- Switch Disconnecter (SANS 60947-3)
- Telecom / datacom equipment
- Lighting control
- UPS equipment
- Alternative energy equipment
- Mobile power generation equipment
- Railway signalling equipment
- Residential equipment
- Industrial equipment

Optional Accessories

- Handle lock
- Surface mounting clips
- Busbar
- Escutcheon blank
- Safety blank





CBM9 (13mm) Miniature Circuit Breakers (MCB)

Technical Data

Product Type	Circuit Breaker				
Approvals	VC 8036 (SANS 556-1)				
Number of Poles	1	2 (1+N)	2	3	4 (3+N)
Operating Voltages	240V AC			415V AC	
Minimum Current Rating	5 A			5 A	
Maximum Current Rating	60 A			50 A	
Specific Ratings (Verify Certification)	5, 6, 7, 8, 9, 10, 12, 15, 16, 20, 25, 30, 35, 40, 45, 50, 60 A				
Interrupting Capacity	2.5 kA				

Product Type	Circuit Breaker				
Approvals	IEC / EN 60947-2, VDE				
Number of Poles	1	2 (1+N)	2	3	4 (3+N)
Operating Voltages	240V AC			415V AC	
Minimum Current Rating	5 A				
Maximum Current Rating	50 A				
Specific Ratings (Verify Certification)	5, 6, 7, 8, 9, 10, 12, 15, 16, 20, 25, 30, 35, 40, 45, 50, 60 A				
Interrupting Capacity	3 kA				

Product Type	Switch Disconnecter			
Approvals	SANS 60947-3			
Number of Poles	1	2	3	4
Operating Voltages	240V AC	415V AC		
Current Rating	63 A			

Auxiliary Module	
Auxiliary Switch	DIN and Mini Rail mounted
Trip Alarm	Mini Rail mount only
Auxiliary Switch / Trip Alarm Combo	Mini Rail mount only

Product Type	CBM9(13)
Operating Temperature Range	-40 °C to +85 °C
Mounting Options	Mini Rail, surface mount
Time Delay Curves	3
Endurance	10000 operations -1500 electrical at rated current and voltage (IEC 60947-2)
Dielectric Strength	1480 V (single pole) / 1830 V (multi pole), 50 Hz for one minute after testing
Weight	102 g per pole, 160 g with auxiliary (depending on rating) (unpacked)
Humidity	35 to 85% relative
Altitude	Certification tests done at altitude ≈ 2000 metres. Will operate at higher altitudes.
Shock	16G (IEC 60068-2-27)
Vibrat	1G (IEC 60068-2-6) (sinusoidal wave)
Flammability	I3 - Ignition does not persist at 850 °C after glow wire is withdrawn with an oxygen index of ≥ 28
Toxicity	F1 - Smoke index of ≤ 20 which determines the fume class
Pollution Degree	PD2 - Normally only non-conductive pollution occurs. Temporary conductivity caused by condensation is to be expected.

Breaker CBM9	Wire Size mm ² (IEC)	Torque (IEC)	Comments
1 Pole to 4 Pole	0.75 - 35 mm ²	2.5 Nm	Pozidriv #2 Combi head



CBM9 (13mm) Miniature Circuit Breakers (MCB)

Time Delay Curves

* The published time delay curves are generated at 30°C ambient temperature with the Circuit Breaker mounted in the up-right position. The “must hold”, “must trip” and “instantaneous trip” current values are not affected by temperature, although delay time for the other operating current values may have to be adjusted using the temperature compensation curve which is available on request.

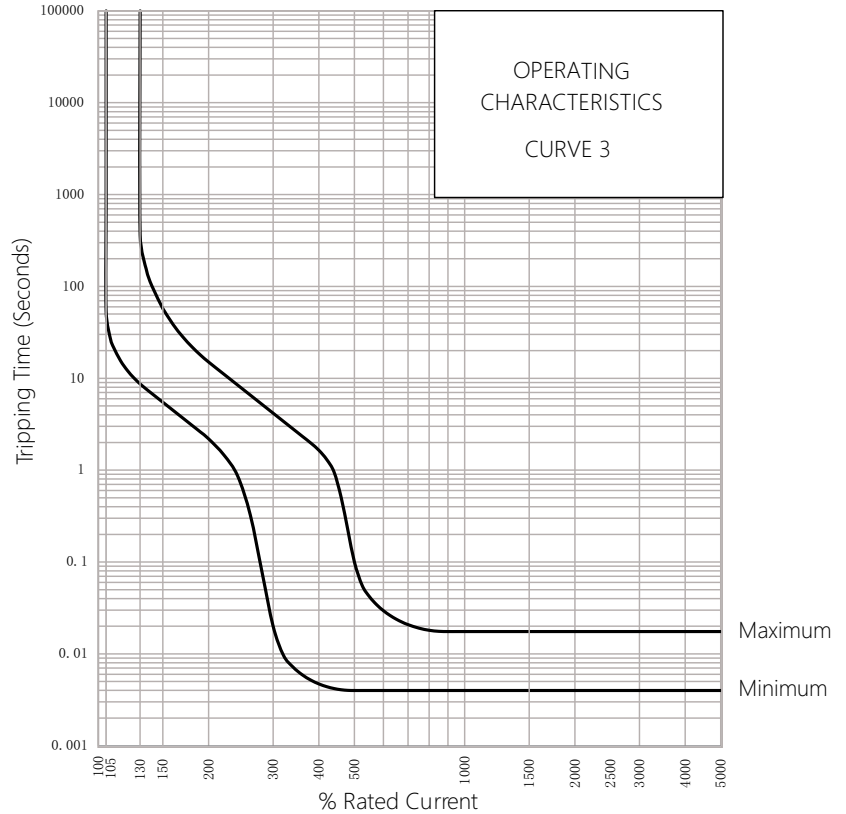

Internal Impedance vs Current Rating

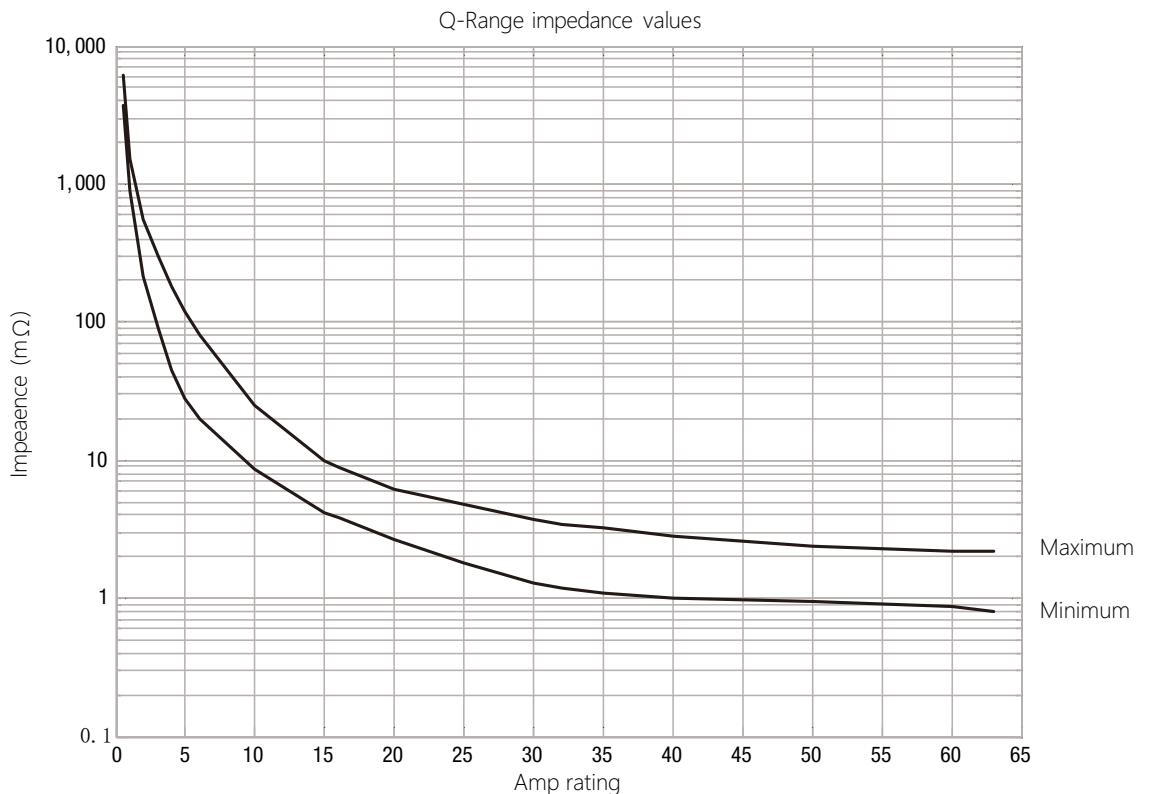



CBM9 (13mm) Miniature Circuit Breakers (MCB)

Outline Dimensions: Mini Rai

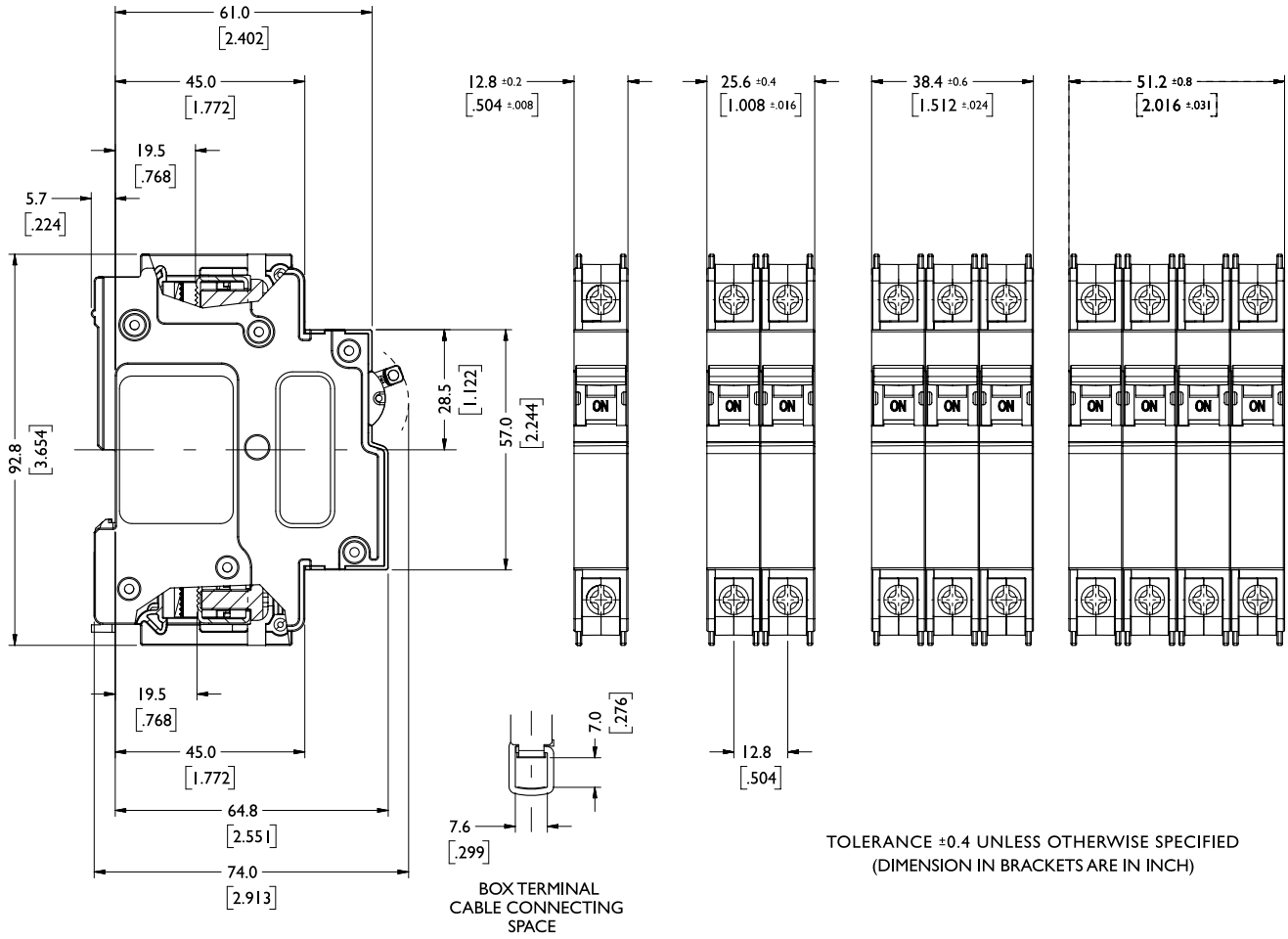



CBL9/CBG9 (13mm) Earth Leakages (RCCB & RCBO)

Features

- Hydraulic-magnetic technology
- 100% rating capability, independent of ambient temperature
- VC 8035 compliant
- VDE and CCC approved, CE certified
- Ratings 5 to 63 A
- Earth leakage sensitivity 30 mA
- Single pole plus switched neutral earth leakage protection
- Switch versions Ptted with short circuit protection
- Available in various currents and time delays
- Precision tripping characteristics
- Compact 26 mm wide module
- Trip indication with mid-trip position
- Reset immediately after overload
- Suitable to use for electrical isolation
- Shell designed for easier installation onto busbar

Applications

- Residential and commercial applications requiring high sensitivity earth leakage protection from electrical shock and Pre hazards
- Earth leakage protection (IEC / EN 60947-2)
- Telecom / datacom equipment
- Lighting control
- UPS equipment
- Alternative energy equipment
- Mobile power generation equipment
- Railway signalling equipment
- Industrial equipment

Auxiliary Switch, Trip Alarm & Combo:

Features

- Auxiliary switch
- Auxiliary switch + trip alarm
- Trip alarm
- AC and DC voltages
- UL 489 listed (auxiliary switch: 6 A 250 V AC, 0.5 A 80 V DC)
- IEC 60947-5-1 approved (Auxiliary Switch: 6 A 240 V AC, 0.5 A 110 V DC; trip alarm: 6 A 240 V AC, 0.5 A 110 V DC)
- Factory Ptted
- Attached to right hand side of circuit breaker
- Compact 6.5 mm width

Optional Accessories

- Rear studs (factory Ptted)
- Handle lock
- Surface mounting clips
- Busbar
- Escutcheon blank
- Safety blank



CBG9: RCBO



CBL9: RCCB





CBL9/CBG9 (13mm) Earth Leakages (RCCB & RCBO)

Technical Data

Product Type	CBG9	CBL9
Approvals	IEC / EN 60947-2, CE	
Number of Poles	2 (1+N)	2 (1+N)
Standard Ampere Ratings	5 to 63 A	40 and 63 A
Sensitivity	30 mA	30 mA
Rated Voltage	240 V	240 V
Rated Interrupting / Withstand Capacity	3 kA -	- 3 kA
Time Delay Curves	2	-

Auxiliary Module	
Auxiliary Switch	DIN and Mini Rail mounted
Trip Alarm	Mini Rail mount only
Auxiliary Switch / Trip Alarm Combo	Mini Rail mount only

Product Type	CBL9 / CBG9
Operating Temperature Range	-40 °C to +85 °C
Mounting Options	Dual mounting (DIN & Mini), surface mount, front mount
Time Delay Curves	2 (A version only)
Endurance	10000 operations - 1500 electrical at rated current and voltage (IEC 60947-2)
Dielectric Strength	1480 V (single pole) / 1830 V (multi pole), 50 Hz for one minute after testing
Weight	262 g - QA17C, 265 g - QA17A (unpacked)
Humidity	35 to 85% relative
Altitude	Certification tests done at altitude ≈ 2000 metres. Will operate at higher altitudes.
Shock	16 G (IEC 600068-2-27)
Vibration	2 G (IEC 600068-2-27) (sinusoidal wave)
Flammability	I3 - Ignition does not persist at 850 °C after glow wire is withdrawn with an oxygen index of ≥ 28
Toxicity	F1 - Smoke index of ≤ 20 which determines the fume class
Pollution Degree	PD2 - Normally only non-conductive pollution occurs. Temporary conductivity caused by condensation is to be expected.

Earth Leakage	Wire Size mm ² (IEC)	Torque (IEC)	Comments
1+N	0.75 - 35 mm ²	2.5 Nm	Pozidriv #2 Combi head



CBL9/CBG9 (13mm) Earth Leakages (RCCB & RCBO)

Time Delay Curves

* The published time delay curves are generated at 30°C ambient temperature with the Circuit Breaker mounted in the up-right position. The “must hold”, “must trip” and “instantaneous trip” current values are not affected by temperature, although delay time for the other operating current values may have to be adjusted using the temperature compensation curve which is available on request.

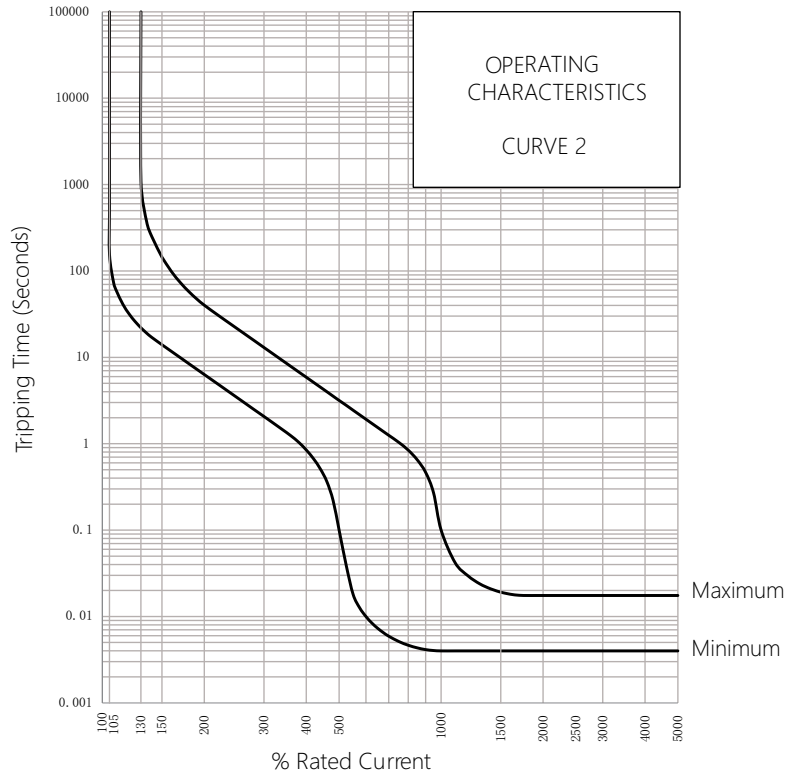

Internal Impedance vs Current Rating

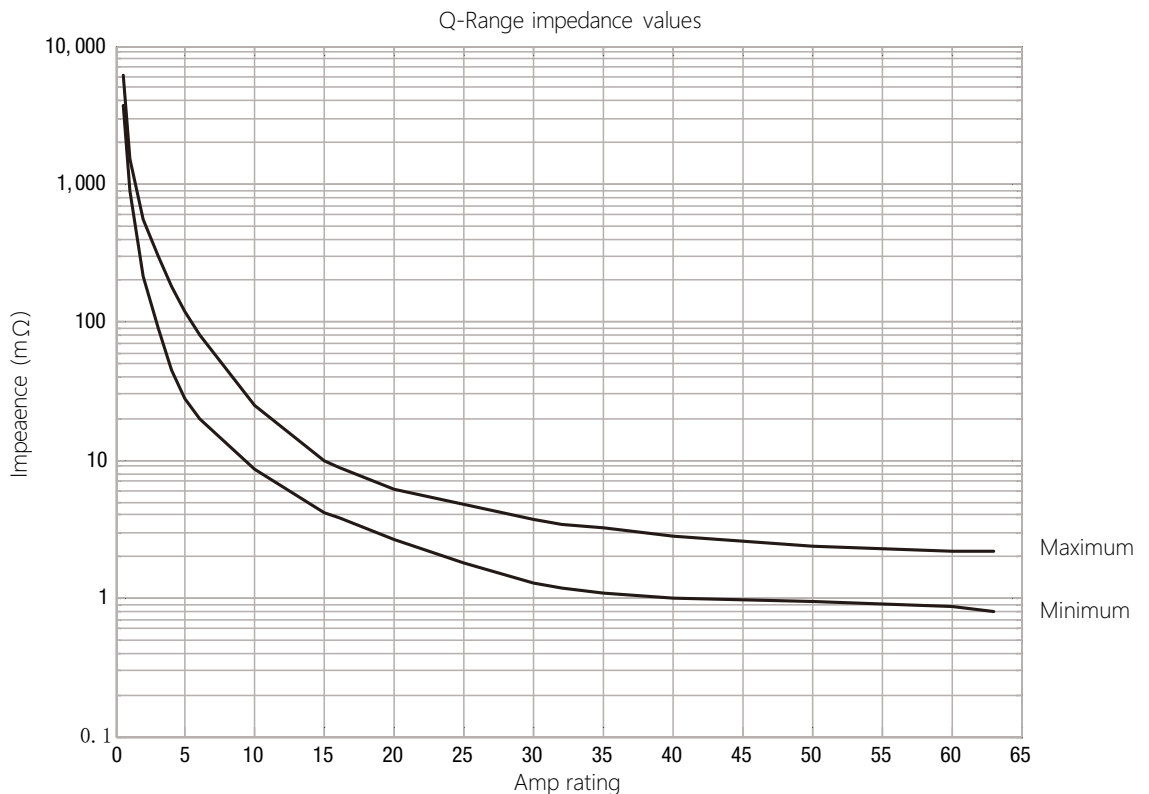



CBL9/CBG9 (13mm) Earth Leakages (RCCB & RCBO)

Outline Dimensions: Dual Mount

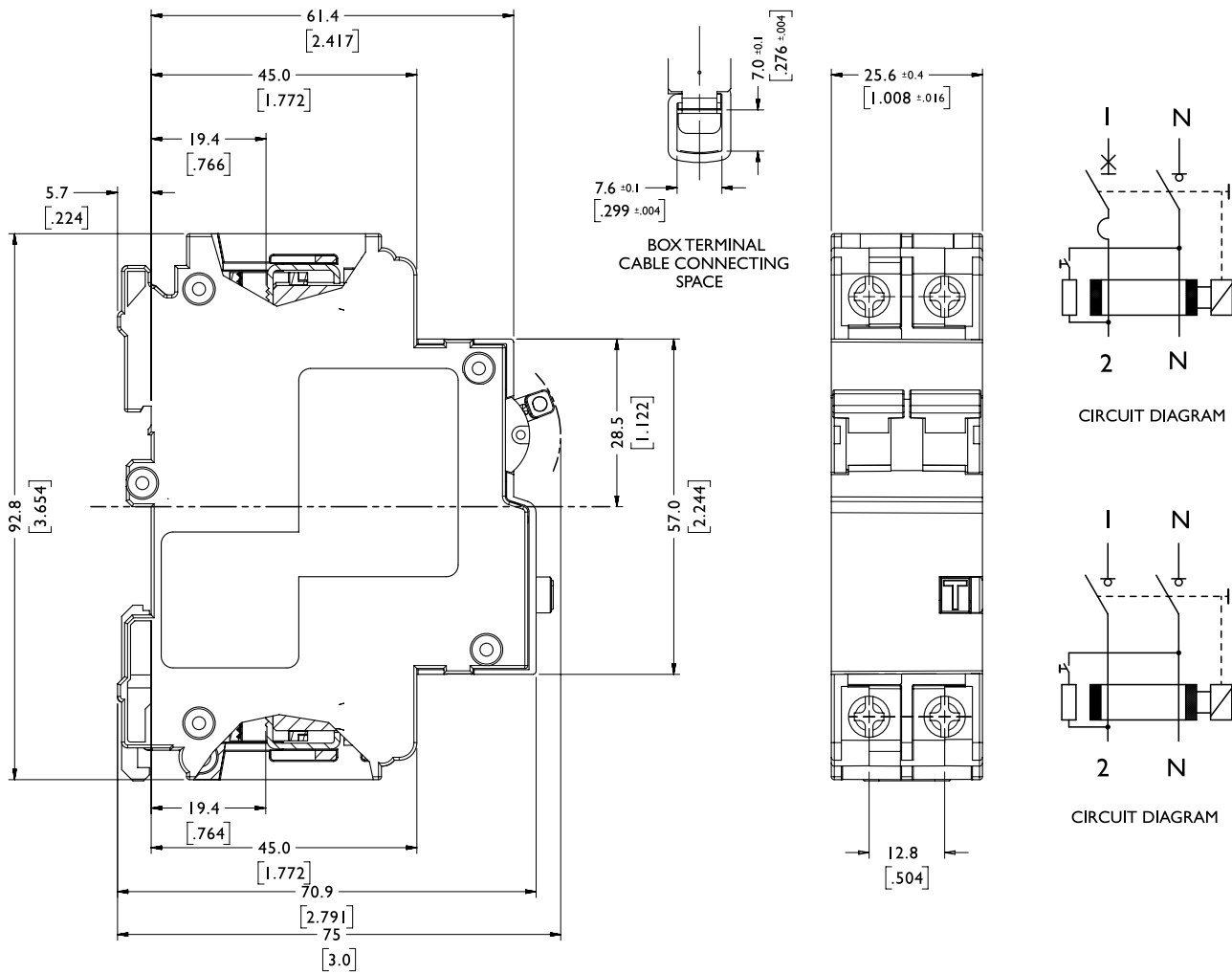

TOLERANCE ±0.4 UNLESS OTHERWISE SPECIFIED
(DIMENSION IN BRACKETS ARE IN INCH)



SAVE ON ENERGY, STARTS FROM ME !



LEADING THE RECYCLING ECONOMY,
INNOVATIVE ENERGY-SAVING EMISSION REDUCTION!

Oldlang Smart Electrical



Low Carbon



Wireless



Energy Saving

E-mail: Oldlang_sale@163.com <http://www.Oldlang.com>

Hangzhou: Future Science And Technology City / Nanjing: Gaochun Economic development zone / Wenzhou: Electric appliance city of China

