



BSI Standards Publication

Electrical accessories - Circuit-breakers for overcurrent protection for household and similar installations

Part 1: Circuit-breakers for a.c. operation

National foreword

This British Standard is the UK implementation of EN 60898-1:2019. It is derived from IEC 60898-1:2015. It supersedes BS EN 60898-1:2003+A13:2012, which will be withdrawn on 18 January 2024.

The CENELEC common modifications have been implemented at the appropriate places in the text. The start and finish of each common modification is indicated in the text by tags **[C]** and **[C]**.

The UK participation in its preparation was entrusted to Technical Committee PEL/23/1, Circuit breakers and similar equipment for household use.

A list of organizations represented on this committee can be obtained on request to its secretary.

This publication does not purport to include all the necessary provisions of a contract. Users are responsible for its correct application.

© The British Standards Institution 2019
Published by BSI Standards Limited 2019

ISBN 978 0 539 03705 0

ICS 11.040.55; 29.120.50

Compliance with a British Standard cannot confer immunity from legal obligations.

This British Standard was published under the authority of the Standards Policy and Strategy Committee on 28 February 2019.

Amendments/corrigenda issued since publication

Date	Text affected
------	---------------

EUROPEAN STANDARD

EN 60898-1

NORME EUROPÉENNE

EUROPÄISCHE NORM

January 2019

ICS 29.120.50

Supersedes EN 60898-1:2003, EN 60898-1:2003/IS1:2007, EN 60898-1:2003/IS2:2007, EN 60898-1:2003/IS3:2007, EN 60898-1:2003/IS4:2007

English Version

**Electrical accessories - Circuit-breakers for overcurrent protection for household and similar installations - Part 1: Circuit-breakers for a.c. operation
(IEC 60898-1:2015 , modified)**

Petit appareillage électrique - Disjoncteurs pour la protection contre les surintensités pour installations domestiques et analogues - Partie 1: Disjoncteurs pour le fonctionnement en courant alternatif
(IEC 60898-1:2015 , modifiée)

Elektrisches Installationsmaterial - Leitungsschutzschalter für Hausinstallationen und ähnliche Zwecke - Teil 1: Leitungsschutzschalter für Wechselstrom (AC)
(IEC 60898-1:2015 , modifiziert)

This European Standard was approved by CENELEC on 2018-05-22. CENELEC members are bound to comply with the CEN/CENELEC Internal Regulations which stipulate the conditions for giving this European Standard the status of a national standard without any alteration.

Up-to-date lists and bibliographical references concerning such national standards may be obtained on application to the CEN-CENELEC Management Centre or to any CENELEC member.

This European Standard exists in three official versions (English, French, German). A version in any other language made by translation under the responsibility of a CENELEC member into its own language and notified to the CEN-CENELEC Management Centre has the same status as the official versions.

CENELEC members are the national electrotechnical committees of Austria, Belgium, Bulgaria, Croatia, Cyprus, the Czech Republic, Denmark, Estonia, Finland, Former Yugoslav Republic of Macedonia, France, Germany, Greece, Hungary, Iceland, Ireland, Italy, Latvia, Lithuania, Luxembourg, Malta, the Netherlands, Norway, Poland, Portugal, Romania, Serbia, Slovakia, Slovenia, Spain, Sweden, Switzerland, Turkey and the United Kingdom.



European Committee for Electrotechnical Standardization
Comité Européen de Normalisation Electrotechnique
Europäisches Komitee für Elektrotechnische Normung

CEN-CENELEC Management Centre: Rue de la Science 23, B-1040 Brussels

European foreword

This document (EN 60898-1:2018) consists of the text of IEC 60898-1:2015 prepared by SC 23E “Circuit-breakers and similar equipment for household use” of IEC/TC 23 “Electrical accessories”, together with the common modifications prepared by CLC/TC 23E “Circuit breakers and similar devices for household and similar applications”.

The following dates are fixed:

- latest date by which this document has to be (dop) 2019-07-18 implemented at national level by publication of an identical national standard or by endorsement
- latest date by which the national standards (dow) 2024-05-28 conflicting with this document have to be withdrawn

This document supersedes EN 60898-1:2003, EN 60898-1:2003/A1:2004, and EN 60898-1:2003/A12:2008.

Clauses, subclauses, notes, tables, figures and annexes which are additional to those in IEC 60898-1:2015 are prefixed “Z”.

Attention is drawn to the possibility that some of the elements of this document may be the subject of patent rights. CENELEC shall not be held responsible for identifying any or all such patent rights.

This document has been prepared under a mandate given to CENELEC by the European Commission and the European Free Trade Association, and supports essential requirements of EU Directive(s).

For the relationship with EU Directive(s) see informative Annex ZZ, which is an integral part of this document.

Endorsement notice

The text of the International Standard IEC 60898-1:2015 was approved by CENELEC as a European Standard with agreed common modifications.

Annex ZA (normative)

Classification of circuit-breakers Type B and C up to and including 63 A into energy limiting classes

Circuit-breakers of B-type and C-type up to and including 63 A, shall be classified into energy limiting classes 1 or 3 in accordance with Table ZA.1 or Table ZA.2, as applicable, and be marked with the number of the energy limiting class in a square adjoining the symbol given in f) of Clause 6.

This classification shall not be applied to circuit-breakers type D and to circuit-breakers with rated current higher than 63 A.

Table ZA.1 – Permissible I^2t (let-through) values for circuit-breakers type B with rated current up to and including 63 A

Rated shortcircuit capacity A	Type B				
	Class 1	Class 3			
	≤ 63 A	≤ 16 A	20 A, 25 A, 32 A	40 A	50 A, 63 A
3 000	No limits specified	15 000	18 000	21 600	28 000
4 500		25 000	32 000	38 400	48 000
6 000		35 000	45 000	54 000	65 000
10 000		70 000	90 000	108 000	135 000

Table ZA.2 – Permissible I^2t (let-through) values for circuit breakers type C with rated current up to and including 63 A

Rated shortcircuit capacity A	Type C				
	Class 1	Class 3			
	≤ 63 A	≤ 16 A	20 A, 25 A, 32 A	40 A	50 A, 63 A
3 000	No limits specified	17 000	20 000	24 000	30 000
4 500		28 000	37 000	45 000	55 000
6 000		40 000	52 000	63 000	75 000
10 000		80 000	100 000	120 000	145 000

The maximum I^2t values measured during the test sequence E1 or E2 as applicable serve as reference values for the classification

Compliance with the requirements of Tables ZA.1 and ZA.2 is checked on the circuit-breakers with the highest rated current available within the range covered by each of these tables.

If these current ratings are not included in the samples submitted to test sequence E₁ or E₂ of Annex C, the appropriate number of samples of these ratings shall be additionally submitted to that test sequence. None of the values measured shall exceed the permissible I^2t value of the proposed energy limiting class in accordance with Tables ZA.1 and ZA.2.

If circuit-breakers rated 40 A are submitted with the range of circuit-breakers with rating exceeding 16 A and their measured I^2t values are lower than those indicated in Table ZA.1 or Table ZA.2 for rating 32 A, no relevant test is necessary for the circuit-breakers rated 32 A.

If circuit-breakers rated 50 A or 63 A are submitted with the range of circuit-breakers with rating exceeding 32 A and their measured I^2t values are lower than those indicated in Table ZA.1 or Table ZA.2 for rating 40 A, no relevant test is necessary for the circuit-breakers rated 40 A.

If circuit-breakers of D-type are submitted with the range of circuit-breakers of type B or type C and their measured I^2t values are lower than those indicated in Table ZA.1 or Table ZA.2 respectively, no relevant test is necessary for the circuit-breakers of type B or type C respectively.

If circuit-breakers of C-type are submitted with the range of circuit-breakers of type B and their measured I^2t values are lower than those indicated in Table ZA.1, no relevant test is necessary for the circuit-breakers of type B.

Annex ZB (normative)

Normative references to international publications with their corresponding European publications

The following documents are referred to in the text in such a way that some or all of their content constitutes requirements of this document. For dated references, only the edition cited applies. For undated references, the latest edition of the referenced document (including any amendments) applies.

NOTE 1 Where an International Publication has been modified by common modifications, indicated by (mod), the relevant EN/HD applies.

NOTE 2 Up-to-date information on the latest versions of the European Standards listed in this annex is available here: www.cenelec.eu.

Publication	Year	Title	EN / HD	Year
IEC 60051	Series	Direct acting indicating analogue electrical measuring instruments and their accessories -	EN 60051	Series
IEC 60112 +A1	2003 2009	Method for the determination of the proof and the comparative tracking indices of solid insulating materials	EN 60112 +A1	2003 2009
IEC 60227	Series	Polyvinyl chloride insulated cables of rated voltages up to and including 450/750V	EN 50525	Series
IEC 60228	2004	Conductors of insulated cables	EN 50525	Series
IEC 60269	Series	Low-voltage fuses	EN 60269	Series
IEC 60364-1 (mod)	2005	Low-voltage electrical installations – Part 1: Fundamental principles, assessment of general characteristics, definitions	HD 60364-1 + A1	2008 2017
IEC 60364-4-41 (mod)	2005	Electrical installations of buildings – Part 4: Protection for safety – Chapter 41: Protection against electric shock	HD 60364-4-41 + A11	2017 2017
IEC 60364-4-43 (mod)	2008	Electrical installations of buildings – Part 4: Protection for safety – Chapter 47: Application of protective measures for safety – Section 473: Measures of protection against overcurrent	HD 60364-4-43	2010
IEC 60417	Datab ase	Graphical symbols for use on equipment. Available from: http://www.graphical-symbols.info/equipment	–	–
IEC 60529 + A1 + A2	1989 1999 2013	Degrees of protection provided by enclosures (IP Code)	EN 60529 + A1 + A2	1991 2000 2013
IEC 60664-1	2007	Insulation co-ordination for equipment within low voltage systems . Part 1: Principles, requirements and tests	EN 60664-1	2007
IEC 60695-2-10	2013	Fire hazard testing - Part 2–10: Glowing/hot-wire based test methods - Glow-wire apparatus and common test procedure	EN 60695-2-10	2013

EN 60898-1:2019 (E)

IEC 60695-2-11	2014	Fire hazard testing - Part 2-11: Glowing/hot-wire based test methods – Glow- wire flammability test method for end products	EN 60695-2-11	2014
IEC 60898-2 +A1 (mod)	2000 2003	Circuit-breakers for overcurrent protection for household and similar installations – Part 2: Circuit-breakers for a.c. and d.c. operation	EN 60898-2	2006
IEC 60947-1	2007	Low-voltage switchgear and controlgear – Part 1 General rules	EN 60947-1	2007
IEC 60947-2	2016	Low-voltage switchgear and controlgear – Part 2 Circuit-breakers	EN 60947-2	2017
IEC 61009-1 +A1 +A2 (mod)	2010 2012 2013	Residual current operated circuit-breakers with integral overcurrent protection for household and similar uses (RCBO's) – Part 1: General rules	EN 61009-1 +A1 +A2 +A11 +A12	2013 2014 2014 2015 2016
IEC 61009-2-1	1991	Residual current operated circuit-breakers with integral overcurrent protection for household and similar use (RCBO's) – Part 2-1: Applicability of the general rules to RCBO's functionally independent of line voltage	EN 61009-2-1 +A11	1994 1998
IEC 61009-2-2	1991	Residual current operated circuit-breakers with integral overcurrent protection for household and similar uses (RCBO's) – Part 2-2: Applicability of the general rules to RCBO's functionally dependent on line voltage	–	–
IEC 61545	1996	Connecting devices – Devices for the connection of aluminium conductors in clamping units of any material and copper conductors in aluminium bodied clamping units	–	-
ISO 2039-2	1987	Plastics – Determination of hardness – Part 2: Rockwell hardness	EN ISO 2039-2	1999
ISO/IEC Guide 2	2004	Standardization and related activities - General vocabulary	–	–

Annex ZC (normative)

Special national conditions

Special national condition: National characteristic or practice that cannot be changed even over a long period, e.g. climatic conditions, electrical earthing conditions.

NOTE If it affects harmonization, it forms part of the European Standard or Harmonization Document.

For the countries in which the relevant special national conditions apply these provisions are normative, for other countries they are informative.

Clause Special national condition

J.1 **Austria, Czech Republic, Netherlands, Norway and Switzerland**

The upper limit of current for use of screwless terminals is 16 A.

J.3.3 **Austria, Belgium, Denmark, France, Germany, Italy, Portugal, Spain and Sweden**

Only universal screwless type terminals are accepted.

K.1 **Belgium, Italy and Spain**

The use of circuit-breakers with flat quick-connect terminations for rated currents up to and including 20 A is accepted.

K.8.2.2 **Belgium, Italy and Spain**

The use for rated currents up to and including 20 A is accepted.

Annex ZD (informative)

List of clauses that require retesting

Based on EN 60898-1:2003, A1:2004, A11:2005, A12:2008 and A13:2012, the following tests and/or requirements have been technically modified and may require retesting or inspection as applicable:

- 9.5.2 in 9.5 Tests of reliability of screw-type terminals for external copper conductors;
- 9.7.4 Insulation resistance and dielectric strength of auxiliary circuits;
- 9.10.3 Test of instantaneous tripping, of correct opening of the contacts and of the trip-free function;
- 9.15 Test Resistance to abnormal heat and to fire.

Annex ZZ (informative)

Relationship between this European standard and the safety objectives of Directive 2014/35/EU [2014 OJ L96] aimed to be covered

This European standard has been prepared under a Commission's standardization request relating to harmonized standards in the field of the Low Voltage Directive, M/511, to provide one voluntary means of conforming to safety objectives of Directive 2014/35/EU of the European Parliament and of the Council of 26 February 2014 on the harmonization of the laws of the Member States relating to the making available on the market of electrical equipment designed for use within certain voltage limits [2014 OJ L96].

Once this standard is cited in the Official Journal of the European Union under that Directive, compliance with the normative clauses of this standard given in Table ZZ.1 confers, within the limits of the scope of this standard, a presumption of conformity with the corresponding safety objectives of that Directive, and associated EFTA regulations.

Table ZZ.1 – Correspondence between this European standard and Article 3 of Directive 2014/35/EU [2014 OJ L153]

Safety Objectives of Directive 2014/35/EU	Clause(s) / subclause(s) of this EN	Remarks / Notes
(1)(a)	1, 2, 3, 4, 5, 6 – 9.3	
(1)(b)	8.1 – 9.4 and 9.5	
(1)(c)	7 – 9.1 and 9.2, Annex I	
(2) (a)	8.3 – 9.6, 8.5 – 9.9, 8.6 – 9.10, 8.7 - 9.11, 8.8 - 9.12, Annex C	
(2) (b)	8.4 – 9.8, 8.5 – 9.9, 8.6 – 9.10, 8.7 - 9.11, 8.8 – 9.12, Annex C	
(2) (c)	8.14, 8.15	
(2) (d)	8.1.3 – Measure, 8.3 – 9.7	
(3) (a)	8.9 – 9.13, 8.12 – 9.16	
(3) (b)	8.10 – 9.14, 8.11 – 9.15	
(3) (c)	8.6 – 9.10, 8.7 – 9.11, 8.8 – 9.12	

WARNING 1: Presumption of conformity stays valid only as long as a reference to this European standard is maintained in the list published in the Official Journal of the European Union. Users of this standard should consult frequently the latest list published in the Official Journal of the European Union.

WARNING 2: Other Union legislation may be applicable to the product(s) falling within the scope of this standard.

CONTENTS

FOREWORD	8
1 Scope	10
2 Normative references	11
3 Terms and definitions	11
3.1 Devices	11
3.2 General terms	12
3.3 Constructional elements	14
3.4 Conditions of operation	17
3.5 Characteristic quantities	17
3.6 Definitions related to insulation co-ordination	22
4 Classification	24
4.1 General	24
4.2 According to the number of poles:	24
4.3 According to the protection against external influences:	24
4.4 According to the method of mounting:	24
4.5 According to the methods of connection	24
4.5.1 According to the fixation system:	24
4.5.2 According to the type of terminals:	24
4.6 According to the instantaneous tripping current (see 3.5.17)	25
4.7 According to the I^2t characteristic	25
5 Characteristics of circuit-breakers	25
5.1 List of characteristics	25
5.2 Rated quantities	25
5.2.1 Rated voltages	25
5.2.2 Rated current (I_n)	26
5.2.3 Rated frequency	26
5.2.4 Rated short-circuit capacity (I_{cn})	26
5.2.5 Rated making and breaking capacity of an individual pole (I_{cn1})	26
5.3 Standard and preferred values	26
5.3.1 Preferred values of rated voltage	26
5.3.2 Preferred values of rated current	27
5.3.3 Standard values of rated frequency	27
5.3.4 Values of rated short-circuit capacity	27
5.3.5 Standard ranges of instantaneous tripping	28
5.3.6 Standard values of rated impulse withstand voltage (U_{imp})	28
6 Marking and other product information	28
6.1 Standard marking	28
6.2 Additional marking	29
6.3 Guidance table for marking	30
7 Standard conditions for operation in service	31
7.1 Standard conditions	31
7.2 Conditions of installation	32
8 Requirements for construction and operation	32
8.1 Mechanical design	32

8.1.1	General	32
8.1.2	Mechanism	32
8.1.3	Clearances and creepage distances (see Annex B)	33
8.1.4	Screws, current-carrying parts and connections	35
8.1.5	Terminals for external conductors	36
8.1.6	Non-interchangeability	38
8.1.7	Mechanical mounting of plug-in type circuit-breakers	39
8.2	Protection against electric shock	39
8.3	Dielectric properties and isolating capability	39
8.3.1	General	39
8.3.2	Dielectric strength at power frequency	40
8.3.3	Isolating capability	40
8.3.4	Dielectric strength at rated impulse withstand voltage (U_{imp})	40
8.4	Temperature-rise	40
8.4.1	Temperature-rise limits	40
8.4.2	Ambient air temperature	40
8.5	Uninterrupted duty	41
8.6	Automatic operation	41
8.6.1	Standard time-current zone	41
8.6.2	Conventional quantities	42
8.6.3	Tripping characteristic	42
8.7	Mechanical and electrical endurance	43
8.8	Performance at short-circuit currents	43
8.9	Resistance to mechanical shock and impact	43
8.10	Resistance to heat	43
8.11	Resistance to abnormal heat and to fire	44
8.12	Resistance to rusting	44
8.13	Power loss	44
8.14	Electromagnetic immunity	44
8.15	Electromagnetic emission	44
9	Tests	44
9.1	Type tests and test sequences	44
9.2	Test conditions	45
9.3	Test of indelibility of marking	46
9.4	Test of reliability of screws, current-carrying parts and connections	46
9.5	Tests of reliability of screw-type terminals for external copper conductors	48
9.6	Test of protection against electric shock	49
9.7	Test of dielectric properties	50
9.7.1	Resistance to humidity	50
9.7.2	Insulation resistance of the main circuit	50
9.7.3	Dielectric strength of the main circuit	51
9.7.4	Insulation resistance and dielectric strength of auxiliary circuits	51
9.7.5	Verification of impulse withstand voltages (across clearances and across solid insulation) and of leakage current across open contacts	52
9.8	Test of temperature-rise and measurement of power loss	54
9.8.1	Ambient air temperature	54
9.8.2	Test procedure	54
9.8.3	Measurement of the temperature of parts	54
9.8.4	Temperature-rise of a part	55
9.8.5	Measurement of power loss	55
9.9	28-day test	55

9.10	Test of tripping characteristic	55
9.10.1	General	55
9.10.2	Test of time-current characteristic.....	55
9.10.3	Test of instantaneous tripping, of correct opening of the contacts and of the trip-free function	56
9.10.4	Test of effect of single-pole loading on the tripping characteristic of multipole circuit-breakers.....	57
9.10.5	Test of effect of ambient temperature on the tripping characteristic	57
9.11	Verification of mechanical and electrical endurance	57
9.11.1	General test conditions	57
9.11.2	Test procedure	58
9.11.3	Condition of the circuit-breaker after test	58
9.12	Short-circuit tests.....	59
9.12.1	General	59
9.12.2	Values of test quantities	59
9.12.3	Tolerances on test quantities	60
9.12.4	Test circuit for short-circuit performance.....	60
9.12.5	Power factor of the test circuit	61
9.12.6	Measurement and verification of I^2t and of the peak current (I_p)	61
9.12.7	Calibration of the test circuit	62
9.12.8	Interpretation of records	62
9.12.9	Condition of the circuit-breaker for test	62
9.12.10	Behaviour of the circuit-breaker during short-circuit tests.....	63
9.12.11	Test procedure	64
9.12.12	Verification of the circuit breaker after short circuit tests	69
9.13	Mechanical stresses	69
9.13.1	Mechanical shock	69
9.13.2	Resistance to mechanical stresses and impact	70
9.14	Test of resistance to heat.....	73
9.15	Resistance to abnormal heat and to fire	74
9.16	Test of resistance to rusting.....	76
Annex A	(informative) Determination of short-circuit power factor	89
A.1	General.....	89
A.2	Method 1 – Determination from d.c. component	89
A.3	Method 2 – Determination with pilot generator	89
Annex B	(normative) Determination of clearances and creepage distances	90
B.1	General.....	90
B.2	Orientation and location of a creepage distance.....	90
B.3	Creepage distances where more than one material is used.....	90
B.4	Creepage distances split by floating conductive part.....	90
B.5	Measurement of creepage distances and clearances	90
Annex C	(normative) Test sequences and number of samples	95
C.1	Test sequences	95
C.2	Number of samples to be submitted for full test procedure and acceptance criteria	97
C.3	Number of samples to be submitted for simplified test procedure	97
Annex D	(informative) Co-ordination under short-circuit conditions between a circuit-breaker and another short-circuit protective device (SCPD) associated in the same circuit.....	101

D.1	General.....	101
D.2	Overview.....	101
D.3	General requirements for the co-ordination of a circuit-breaker with another SCPD	102
D.3.1	General consideration.....	102
D.3.2	Take-over current	102
D.3.3	Behaviour of C ₁ in association with another SCPD	102
D.4	Type and characteristics of the associated SCPD	102
D.5	Verification of selectivity	103
D.6	Verification of back-up protection.....	103
D.6.1	Determination of the take-over current.....	103
D.6.2	Verification of back-up protection.....	103
D.6.3	Tests for verification of back-up protection	104
D.6.4	Results to be obtained	105
Annex E	108
Annex F (informative)	Examples of terminals	109
Annex G	112
Annex H (normative)	Arrangement for short-circuit test.....	113
Annex I (normative)	Routine tests	116
I.1	General.....	116
I.2	Tripping tests	116
I.3	Verification of clearances between open contacts	116
Annex J (normative)	Particular requirements for circuit-breakers with screwless type terminals for external copper conductors.....	117
J.1	Scope	117
J.2	Normative references.....	117
J.3	Terms and definitions.....	117
J.4	Classification	118
J.5	Characteristics of circuit-breakers.....	118
J.6	Marking.....	118
J.7	Standard conditions for operation in service.....	118
J.8	Constructional requirements	119
J.8.1	Connection or disconnection of conductors	119
J.8.2	Dimensions of connectable conductors	119
J.8.3	Connectable cross-sectional areas	120
J.8.4	Insertion and disconnection of conductors	120
J.8.5	Design and construction of terminals	120
J.8.6	Resistance to ageing	121
J.9	Tests	121
J.9.1	Test of reliability of screwless terminals.....	121
J.9.2	Tests of reliability of terminals for external conductors: mechanical strength	122
J.9.3	Cycling test.....	122
J.10	Reference documents	124
Annex K (normative)	Particular requirements for circuit-breakers with flat quick-connect terminations.....	126
K.1	Scope	126
K.2	Normative references.....	126

K.3	Terms and definitions.....	126
K.4	Classification	127
K.5	Characteristics of circuit-breakers.....	127
K.6	Marking.....	127
K.7	Standard conditions for operation in service.....	127
K.8	Constructional requirements	127
K.8.1	Clearances and creepage distances (see Annex B)	127
K.8.2	Terminals for external conductors	128
K.9	Tests	128
K.9.1	Mechanical overload-force.....	128
K.10	Reference documents	132
Annex L	133
Bibliography	134
Figure 1	– Thread forming tapping screw (3.3.22).....	75
Figure 2	– Thread cutting tapping screw (3.3.23)	75
Figure 3	– Typical diagram for all short circuit tests except for 9.12.11.2.2)	76
Figure 4	– Typical diagram for short circuit tests according to 9.12.11.2.2)	77
Figure 5	– Detail of impedance Z and Z_1	77
Figure 6	– Calibration of the test circuit	79
Figure 7	– Mechanical shock test apparatus (9.13.1)	80
Figure 8	– Standard test finger (9.6)	81
Figure 9	– Mechanical impact test apparatus (9.13.2)	82
Figure 10	– Striking element for pendulum for mechanical impact test apparatus (9.13.2).....	83
Figure 11	– Mounting support for mechanical impact test (9.13.2).....	84
Figure 12	– Example of mounting for a flush type fixed circuit-breaker for mechanical impact test.....	85
Figure 13	– Example of mounting of a panel board type circuit-breaker for mechanical impact test (9.13.2).....	86
Figure 14	– Application of force for mechanical test on a rail-mounted circuit-breaker (9.13.2.3).....	87
Figure 15	– Ball-pressure test apparatus.....	87
Figure 16	– Example of application of force for mechanical test on two-pole plug-in circuit-breaker, the holding in position of which depends solely on the plug-in connections (9.13.2.4)	88
Figure 17	– Diagrammatic representation (9.15)	88
Figure B.1	– Examples of methods of measuring creepage distances and clearances.....	94
Figure D.1	– Overcurrent co-ordination between a circuit-breaker and a fuse or back- up protection by a fuse – Operating characteristics.....	106
Figure D.2	– Total selectivity between two circuit-breakers	106
Figure D.3	– Back-up protection by a circuit-breaker – Operating characteristics	107
Figure F.1	– Examples of pillar terminals	109
Figure F.2	– Examples of screw terminals and stud terminals	110
Figure F.3	– Examples of saddle terminals.....	111
Figure F.4	– Examples of lug terminals	111

Figure H.1 – Test arrangement	114
Figure H.2 – Grid circuit.....	114
Figure H.3 – Grid circuit.....	115
Figure J.1 – Connecting samples	122
Figure J.2 – Examples of screwless-type terminals	124
Figure K.1 – Example of position of the thermocouple for measurement of the temperature-rise	129
Figure K.2 – Dimensions of male tabs.....	130
Figure K.3 – Dimensions of round dimple detents (see Figure K.2)	131
Figure K.4 – Dimensions of rectangular dimple detents (see Figure K.2).....	131
Figure K.5 – Dimensions of hole detents	131
Figure K.6 – Dimensions of female connectors	132
Table 1 – Standard values of rated voltage.....	27
Table 2 – Ranges of instantaneous tripping	28
Table 3 –	28
Table 4 – Minimum clearances and creepage distances.....	34
Table 5 – Connectable cross-sections of copper conductors for screw-type terminals.....	37
Table 6 – Temperature-rise values.....	40
Table 7 – Time-current operating characteristics.....	42
Table 8 – Maximum power loss per pole	44
Table 9 – List of type tests.....	45
Table 10 – Cross-sectional areas (<i>S</i>) of test copper conductors corresponding to the rated currents	46
Table 11 – Screw thread diameters and applied torques	47
Table 12 – Pulling forces	48
Table 13 – Test voltage of auxiliary circuits	52
Table 14 – Test voltage for verification of impulse withstand voltage	53
Table 15 – Test voltage for verifying the suitability for isolation, referred to the rated impulse withstand voltage of the circuit breakers and the altitude where the test is carried out	54
Table 16 – Applicability of short-circuit tests	59
Table 17 – Power factor ranges of the test circuit	61
Table 18 – Ratio <i>k</i> between service short-circuit capacity (<i>I_{CS}</i>) and rated short-circuit capacity (<i>I_{CN}</i>).....	66
Table 19 – Test procedure for <i>I_{CS}</i> in the case of single- and two-pole circuit-breakers	66
Table 20 – Test procedure for <i>I_{CS}</i> in the case of three- and four-pole circuit-breakers.....	67
Table 21 – Test procedure for <i>I_{CS}</i> in the case of three-phase tests for single-pole circuit-breakers of rated voltage 230/400 V	67
Table 22 – The test procedure for <i>I_{CN}</i>	68
Table 23 – Test procedure for <i>I_{CN}</i> in the case of three-phase tests for single-pole circuit-breakers of rated voltage 230/400 V	68
Table C.1 – Test sequences	96
Table C.2 – Number of samples for full test procedure.....	97

Table C.3 – Reduction of samples for series of circuit-breakers having different numbers of poles	99
Table C.4 – Test sequences for a series of circuit-breakers being of different instantaneous tripping classifications	100
Table J.1 – Connectable conductors	120
Table J.2 – Cross-sections of copper conductors connectable to screwless-type terminals.....	120
Table J.3 – Pull forces	122
Table K.1 – Informative table on colour code of female connectors in relationship with the cross section of the conductor.....	127
Table K.2 – Overload test forces.....	128
Table K.3 – Dimensions of tabs	129
Table K.4 – Dimensions of female connectors.....	132

INTERNATIONAL ELECTROTECHNICAL COMMISSION

**ELECTRICAL ACCESSORIES –
CIRCUIT-BREAKERS FOR OVERCURRENT PROTECTION
FOR HOUSEHOLD AND SIMILAR INSTALLATIONS –****Part 1: Circuit-breakers for a.c. operation**

FOREWORD

- 1) The International Electrotechnical Commission (IEC) is a worldwide organization for standardization comprising all national electrotechnical committees (IEC National Committees). The object of IEC is to promote international co-operation on all questions concerning standardization in the electrical and electronic fields. To this end and in addition to other activities, IEC publishes International Standards, Technical Specifications, Technical Reports, Publicly Available Specifications (PAS) and Guides (hereafter referred to as "IEC Publication(s)"). Their preparation is entrusted to technical committees; any IEC National Committee interested in the subject dealt with may participate in this preparatory work. International, governmental and non-governmental organizations liaising with the IEC also participate in this preparation. IEC collaborates closely with the International Organization for Standardization (ISO) in accordance with conditions determined by agreement between the two organizations.
- 2) The formal decisions or agreements of IEC on technical matters express, as nearly as possible, an international consensus of opinion on the relevant subjects since each technical committee has representation from all interested IEC National Committees.
- 3) IEC Publications have the form of recommendations for international use and are accepted by IEC National Committees in that sense. While all reasonable efforts are made to ensure that the technical content of IEC Publications is accurate, IEC cannot be held responsible for the way in which they are used or for any misinterpretation by any end user.
- 4) In order to promote international uniformity, IEC National Committees undertake to apply IEC Publications transparently to the maximum extent possible in their national and regional publications. Any divergence between any IEC Publication and the corresponding national or regional publication shall be clearly indicated in the latter.
- 5) IEC itself does not provide any attestation of conformity. Independent certification bodies provide conformity assessment services and, in some areas, access to IEC marks of conformity. IEC is not responsible for any services carried out by independent certification bodies.
- 6) All users should ensure that they have the latest edition of this publication.
- 7) No liability shall attach to IEC or its directors, employees, servants or agents including individual experts and members of its technical committees and IEC National Committees for any personal injury, property damage or other damage of any nature whatsoever, whether direct or indirect, or for costs (including legal fees) and expenses arising out of the publication, use of, or reliance upon, this IEC Publication or any other IEC Publications.
- 8) Attention is drawn to the Normative references cited in this publication. Use of the referenced publications is indispensable for the correct application of this publication.
- 9) Attention is drawn to the possibility that some of the elements of this IEC Publication may be the subject of patent rights. IEC shall not be held responsible for identifying any or all such patent rights.

International Standard IEC 60898-1 has been prepared by sub-committee 23E: Circuit-breakers and similar equipment for household use, of IEC technical committee 23: Electrical accessories.

This second edition cancels and replaces the first edition published in 2002, Amendment 1:2002 and Amendment 2:2003. This edition constitutes a technical revision.

This edition includes the following significant technical changes with respect to the previous edition:

- a) Revision of 9.5 Terminals
- b) Revision of the test of glow wire
- c) Simplification of the figures for short circuit tests.

The text of this standard is based on the following documents:

FDIS	Report on voting
23E/881/FDIS	23E/894/RVD

Full information on the voting for the approval of this standard can be found in the report on voting indicated in the above table.

This publication has been drafted in accordance with the ISO/IEC Directives, Part 2.

In this standard, the following print types are used:

- Requirements proper: in roman type.
- *Test specifications: in italic type.*
- Explanatory matter: in smaller roman type.

A list of all parts in the IEC 60898 series, published under the general title *Electrical accessories – Circuit-breakers for overcurrent protection for household and similar installations*, can be found on the IEC website.

The committee has decided that the contents of this publication will remain unchanged until the stability date indicated on the IEC website under "<http://webstore.iec.ch>" in the data related to the specific publication. At this date, the publication will be

- reconfirmed,
- withdrawn,
- replaced by a revised edition, or
- amended.

A bilingual version of this publication may be issued at a later date.

The contents of the corrigendum of November 2015 have been included in this copy.

ELECTRICAL ACCESSORIES – CIRCUIT-BREAKERS FOR OVERCURRENT PROTECTION FOR HOUSEHOLD AND SIMILAR INSTALLATIONS –

Part 1: Circuit-breakers for a.c. operation

1 Scope

This part of IEC 60898 applies to a.c. air-break circuit-breakers for operation at 50 Hz, 60 Hz or 50/60 Hz, having a rated voltage not exceeding 440 V (between phases), a rated current not exceeding 125 A and a rated short-circuit capacity not exceeding 25 000 A.

As far as possible, it is in line with the requirements contained in IEC 60947-2.

These circuit-breakers are intended for the protection against overcurrents of wiring installations of buildings and similar applications; they are designed for use by uninstructed people and for not being maintained.

They are intended for use in an environment with pollution degree 2 [C] and overvoltage category III. [C1]

[E] NOTE 1 Additional requirements are necessary for circuit-breakers used in locations having more severe overvoltage conditions. [C]

They are suitable for isolation.

[C] Circuit-breakers of this standard are suitable for use in IT systems provided that the requirements of HD 60364-4-43 are complied with. [C]

This standard also applies to circuit-breakers having more than one rated current, provided that the means for changing from one discrete rating to another is not accessible in normal service and that the rating cannot be changed without the use of a tool.

This standard does not apply to

- circuit-breakers intended to protect motors;
- circuit-breakers, the current setting of which is adjustable by means accessible to the user.

For circuit-breakers having a degree of protection higher than IP20 according to IEC 60529, for use in locations where arduous environmental conditions prevail (e.g. excessive humidity, heat or cold or deposition of dust) and in hazardous locations (e.g. where explosions are liable to occur), special constructions may be required.

This standard does not apply to circuit-breakers for a.c. and d.c. operation, which is covered by IEC 60898-2.

This standard does not apply to circuit-breakers which incorporate residual current tripping devices, which is covered by IEC 61009-1, IEC 61009-2-1, and IEC 61009-2-2.

[C] Supplementary requirements may be necessary for circuit-breakers of the screw-in types. [C]

A guide for co-ordination under short-circuit conditions between a circuit-breaker and another short-circuit protective device (SCPDs) is given in Annex D. For more severe overvoltage conditions, circuit-breakers complying with other standards (e.g. IEC 60947-2) should be used.

For an environment with a higher pollution degree, enclosures giving the appropriate degree of protection should be used.

NOTE 2 Circuit-breakers within the scope of this standard can also be used for protection against electric shock in case of fault, depending on their tripping characteristics and on the characteristics of the installation. The criterion of application for such purposes is dealt with by installation rules.

- ☒ NOTE 3 Recommendations for the dimensional coordination between enclosures and circuit-breakers for mounting on rails according to EN 60715 or equivalent means are given in the CENELEC report PD CLC/TR 50473. ☒

This standard contains all requirements necessary to ensure compliance with the operational characteristics required for these devices by type tests.

It also contains the details relative to test requirements and methods of testing necessary to ensure reproducibility of test results.

This standard states

- a) the characteristics of circuit-breakers;
- b) the conditions with which circuit-breakers shall comply, with reference to:
 - 1) their operation and behaviour in normal service;
 - 2) their operation and behaviour in case of overload;
 - 3) their operation and behaviour in case of short-circuits up to their rated short-circuit capacity;
 - 4) their dielectric properties;
- c) the tests intended for confirming that these conditions have been met and the methods to be adopted for the tests;
- d) the data to be marked on the devices;
- e) the test sequences to be carried out and the number of samples (see Annex C);
- f) the co-ordination under short-circuit conditions with another short-circuit protective device (SCPD) associated in the same circuit (see Annex D);
- g) the routine tests to be carried out on each circuit-breaker to reveal unacceptable variations in material or manufacture, likely to affect safety (see Annex I).

2 Normative references

- ☒ NOTE Normative references to international standards are given in Annex ZB. ☒

3 Terms and definitions

For the purposes of this document, the terms and definitions given in IEC 60050-441, as well as the following apply.

3.1 Devices

3.1.1

switching device

device designed to make or break the current in one or more electric circuits

[SOURCE: IEC 60050-441:1984, 441-14-01]

3.1.2

mechanical switching device

switching device designed to close and open one or more electric circuits by means of separable contacts

[SOURCE: IEC 60050-441:1984, 441-14-02]

3.1.3**fuse**

device that, by the fusing of one or more of its specially designed and proportioned components, opens the circuit in which it is inserted and breaks the current when this exceeds a given value for a sufficient time

[SOURCE: IEC 60050-441:1984, 441-18-01, modified – "The fuse comprises all the parts that form the complete device" has been deleted.]

3.1.4**circuit-breaker**

<mechanical> mechanical switching device, capable of making, carrying and breaking currents under normal circuit conditions and also making, carrying for a specified time, and automatically breaking currents under specified abnormal circuit conditions such as those of short-circuit

[SOURCE: IEC 60050-441:1984, 441-14-20]

3.1.5**plug-in circuit-breaker**

circuit-breaker having one or more plug-in terminals (see 3.3.20) and designed for use with appropriate means for the plug-in connection

3.2 General terms**3.2.1****overcurrent**

current exceeding the rated current

[SOURCE: IEC 60050-441:1984, 441-11-06]

3.2.2**overload current**

overcurrent occurring in an electrically undamaged circuit

Note 1 to entry: An overload current may cause damage if sustained for a sufficient time.

3.2.3**short-circuit current**

overcurrent resulting from a fault of negligible impedance between points intended to be at different potentials in normal service

Note 1 to entry: A short-circuit current may result from a fault or from an incorrect connection.

3.2.4**main circuit**

<of a circuit-breaker> all the conductive parts of a circuit-breaker included in the circuit which it is designed to close and open

3.2.5**control circuit**

<of a circuit-breaker> circuit (other than a path of the main circuit) intended for the closing operation or opening operation, or both, of the circuit-breaker

3.2.6**auxiliary circuit**

<of a circuit-breaker> all the conductive parts of a circuit-breaker intended to be included in a circuit other than the main circuit and the control circuit of the circuit-breaker

3.2.7**pole**

<of a circuit-breaker> that part of a circuit-breaker associated exclusively with one electrically separated conducting path of its main circuit provided with contacts intended to connect and disconnect the main circuit itself and excluding those portions which provide a means for mounting and operating the poles together

3.2.7.1**protected pole**

pole provided with an overcurrent release (see 3.3.6)

3.2.7.2**unprotected pole**

pole without overcurrent release (see 3.3.6), but otherwise generally capable of the same performance as a protected pole of the same circuit-breaker

Note 1 to entry: To ensure compliance with this requirement, the unprotected pole may be of the same construction as the protected pole(s), or of a particular construction.

Note 2 to entry: If the short-circuit capacity of the unprotected pole is different from that of the protected pole(s), this has to be indicated by the manufacturer.

3.2.7.3**switched neutral pole**

pole only intended to switch the neutral, and not intended to have a short-circuit capacity

3.2.8**closed position**

position in which the predetermined continuity of the main circuit of the circuit-breaker is secured

3.2.9**open position**

position in which the predetermined clearance between open contacts in the main circuit of the circuit-breaker is secured

3.2.10**air temperature****3.2.10.1****ambient air temperature**

temperature, determined under prescribed conditions, of the air surrounding the circuit-breaker

Note 1 to entry: For circuit breakers installed inside an enclosure, it is the temperature of air outside the enclosure

[SOURCE: IEC 60050-441:1984, 441-11-13, modified – "complete switching device or fuse" has been replaced by "circuit-breaker".]

3.2.10.2**reference ambient air temperature**

ambient air temperature on which the time-current characteristics are based

3.2.11**operation**

transfer of the moving contact(s) from the open position to the closed position or vice versa

Note 1 to entry: If distinction is necessary, an operation in the electrical sense (make or break) is referred to as a "switching operation" and an operation in the mechanical sense (close or open) is referred to as a "mechanical operation".

3.2.12**operating cycle**

succession of operations from one position to another and back to the first position

3.2.13**operation sequence**

<of a mechanical switching device> succession of specified operations with specified time intervals

[SOURCE: IEC 60050-441:1984, 441-16-03]

3.2.14**uninterrupted duty**

duty in which the main contacts of a circuit-breaker remain closed whilst carrying a steady current without interruption for long periods (which could be weeks, months, or even years)

**3.2.15****type test**

test of one or more devices made to a certain design to show that the design meets certain requirements

[SOURCE: IEC 60050-441:1984, 441-53-01, modified]

**3.2.16****routine test**

test to which each individual device is subjected during or after manufacture to ascertain whether it complies with certain criteria

[SOURCE: IEC 411-53-02, modified]

3.3 Constructional elements**3.3.1****main contact**

contact included in the main circuit of a circuit-breaker and intended to carry in the closed position the current of the main circuit

3.3.2**arcing contact**

contact on which the arc is intended to be established

Note 1 to entry: An arcing contact may serve as a main contact. It may also be a separate contact so designed that it opens after and closes before another contact, which it is intended to protect from damage.

[SOURCE: IEC 60050-441:1984, 441-15-08]

3.3.3**control contact**

contact included in a control circuit of a circuit-breaker and mechanically operated by the circuit-breaker

3.3.4**auxiliary contact**

contact included in an auxiliary circuit and mechanically operated by the circuit-breaker (e.g. for indicating the position of the contacts)

3.3.5**release**

device, mechanically connected to (or integrated into) a circuit-breaker, which releases the holding means and permits the automatic opening of the circuit-breaker

3.3.6**overcurrent release**

release which causes a circuit-breaker to open, with or without time-delay, when the current in the release exceeds a pre-determined value

Note 1 to entry: In some cases this value can depend upon the rate of rise of current.

3.3.7**inverse time-delay overcurrent release**

overcurrent release which operates after a time-delay inversely dependent upon the value of the overcurrent

Note 1 to entry: Such a release may be designed so that the time-delay approaches a definite minimum for high values of overcurrent.

3.3.8**direct overcurrent release**

overcurrent release directly energized by the current in the main circuit of a circuit-breaker

3.3.9**overload release**

overcurrent release intended for protection against overloads

3.3.10**conductive part**

part which is capable of conducting current although it may not necessarily be used for carrying current in normal service

3.3.11**exposed conductive part**

conductive part which can be readily touched and which normally is not live, but which may become live under fault conditions

Note 1 to entry: Typical exposed conductive parts are walls of metal enclosures, metal operating handles, etc.

3.3.12**terminal**

conductive part of a device, provided for re-usable electrical connection to external circuits

3.3.12.1**screw-type terminal**

terminal for the connection and subsequent disconnection of a conductor or the inter-connection of two or more conductors, capable of being dismantled, the connection being made, directly or indirectly, by means of screws or nuts of any kind

3.3.12.2**pillar terminal**

screw-type terminal in which the conductor is inserted into a hole or cavity, where it is clamped under the shank of the screw(s).

Note 1 to entry: The clamping pressure may be applied directly by the shank of the screw or through an intermediate clamping element to which pressure is applied by the shank of the screw

Note 2 to entry: Examples of pillar terminals are shown in Annex F, Figure F.1.

[SOURCE: IEC 60050-442:1984, 442-06-22]

3.3.12.3**screw terminal**

terminal in which the conductor is clamped under the head of the screw and where the clamping pressure can be applied directly by the head of the screw or through an intermediate part, such as a washer, a clamping plate or an anti-spread device

Note 1 to entry: Examples of screw terminals are shown in Annex F, Figure F.2.

[SOURCE: IEC 60050-442:1984, 442-06-08]

3.3.12.4

stud terminal

screw-type terminal in which the conductor is clamped under a nut.

Note 1 to entry: The clamping pressure may be applied directly by a suitably shaped nut or through an intermediate part, such as a washer, a clamping plate or an anti-spread device

Note 2 to entry: Examples of stud terminals are shown in Annex F, Figure F.2.

[SOURCE: IEC 60050-442:1984, 442-06-23]

3.3.12.5

saddle terminal

screw-type terminal in which the conductor is clamped under a saddle by means of two or more screws or nuts

Note 1 to entry: Examples of saddle terminals are shown in Annex F, Figure F.3.

[SOURCE: IEC 60050-442:1984, 442-06-09]

3.3.12.6

lug terminal

screw terminal or stud terminal, designed for clamping a cable lug or a bar directly or indirectly by means of a screw or nut

Note 1 to entry: Examples of lug terminals are shown in Annex F, Figure F.4.

[SOURCE: IEC 60050-442:1984, 442-06-16]

3.3.12.7

screwless terminal

connecting terminal for the connection and subsequent disconnection of one conductor or the interconnection of two or more conductors capable of being dismantled, the connection being made, directly or indirectly, by means of springs, wedges, eccentrics or cones, etc., without special preparation of the conductor other than removal of insulation

[SOURCE: IEC 60050-442:1984, 442-06-13 modified by adding the last part of the text]

3.3.12.8

plug-in terminal

terminal the electrical connection and disconnection of which can be effected without displacing the conductors of the corresponding circuit

Note 1 to entry: The connection is effected without the use of a tool and is provided by the resilience of the fixed and/or moving parts and/or by springs

3.3.13

tapping screw

screw manufactured from a material having a greater resistance to deformation when applied by rotary insertion to a hole in a material having a lesser resistance to deformation.

Note 1 to entry: The screw is made with a tapered thread, the taper being applied to the core diameter of the thread at the end section of the screw.

Note 2 to entry: The thread produced by application of the screw is formed securely only after sufficient revolutions have been made to exceed the number of threads on the tapered section

3.3.13.1**thread-forming tapping screw**

tapping screw having an uninterrupted thread

Note 1 to entry: It is not a function of this thread to remove material from the hole

Note 2 to entry: An example of thread-forming tapping screw is shown in Figure 1.

3.3.13.2**thread-cutting tapping screw**

tapping screw having an interrupted thread. The thread is intended to remove material from the hole.

Note 1 to entry: An example of thread-cutting tapping screw is shown in Figure 2.

3.4 Conditions of operation**3.4.1****closing operation**

operation by which the circuit-breaker is brought from the open position to the closed position

3.4.2**opening operation**

operation by which the circuit-breaker is brought from the closed position to the open position

3.4.3**dependent manual operation**

operation solely by means of directly applied manual energy, such that the speed and force of the operation are dependent upon the action of the operator

[SOURCE: IEC 60050-441:1984, 441-16-13]

3.4.4**independent manual operation**

stored energy operation where the energy originates from manual power, stored and released in one continuous operation, such that the speed and force of the operation are independent of the action of the operator

[SOURCE: IEC 60050-441:1984, 441-16-16]

3.4.5**trip-free circuit-breaker**

circuit-breaker, the moving contacts of which return to and remain in the open position when the automatic opening operation is initiated after the initiation of the closing operation, even if the closing command is maintained

Note 1 to entry: To ensure proper breaking of the current which may have been established, it may be necessary that the contacts momentarily reach the closed position.

3.5 Characteristic quantities

NOTE Unless otherwise specified, all values of current and voltage are r.m.s. values.

3.5.1**rated value**

stated value of any one of the characteristic quantities that serve to define the working conditions for which the circuit-breaker is designed and built

3.5.2**prospective current**

current that would flow in the circuit if each pole of the circuit-breaker were replaced by a conductor of negligible impedance

Note 1 to entry: The prospective current may be qualified in the same manner as an actual current, for example prospective breaking current, prospective peak current.

[SOURCE: IEC 60050-441:1984, 441-17-01, modified – "complete switching device or fuse" has been replaced by "circuit-breaker".]

3.5.3

prospective peak current

peak value of a prospective current during the transient period following initiation

Note 1 to entry: The definition assumes that the current is established by an ideal circuit-breaker, that is, with instantaneous transition from infinite to zero impedance. For circuits where the current can follow several different paths, for example polyphase circuits, it further assumes that the current is established simultaneously in all poles, even if the current in only one pole is considered.

[SOURCE: IEC 60050-441:1984, 441-17-02]

3.5.4

maximum prospective peak current

prospective peak current when the initiation of the current takes place at the instant which leads to the highest possible value

Note 1 to entry: For a multipole circuit-breaker in a polyphase circuit, the maximum prospective peak current refers to a single pole only.

[SOURCE: IEC 60050-441:1984, 441-17-04]

3.5.5

short-circuit making and breaking capacity

alternating component of the prospective current, expressed by its r.m.s. value, which the circuit-breaker is designed to make, to carry for its opening time and to break under specified conditions

3.5.5.1

ultimate short-circuit breaking capacity

breaking capacity for which the prescribed conditions according to a specified test sequence do not include the capability of the circuit-breaker to carry 0,85 times its non-tripping current for the conventional time

3.5.5.2

service short-circuit breaking capacity

breaking capacity for which the prescribed conditions according to a specified test sequence include the capability of the circuit-breaker to carry 0,85 times its non-tripping current for the conventional time

3.5.6

breaking current

current in a pole of a circuit-breaker at the instant of initiation of the arc during a breaking operation

3.5.7

applied voltage

voltage which exists across the terminals of a pole of a circuit-breaker just before the making of the current

Note 1 to entry: This definition refers to a single-pole device. For a multipole device the applied voltage is the voltage across the supply terminals of the device.

3.5.8

recovery voltage

voltage which appears across the terminals of a pole of a circuit-breaker after the breaking of the current

Note 1 to entry: This voltage may be considered in two successive intervals of time, one during which a transient voltage exists, followed by a second one during which the power-frequency or the steady-state recovery voltage alone exists.

Note 2 to entry: This definition refers to a single-pole device. For a multipole device the recovery voltage is the voltage across the supply terminals of the device.

[SOURCE: IEC 60050-441:1984, 441-17-25, modified –Note 2 to entry has been added.]

3.5.8.1

transient recovery voltage

recovery voltage during the time in which it has a significant transient character

Note 1 to entry: The transient voltage may be oscillatory or non-oscillatory or a combination of these, depending on the characteristics of the circuit and of the circuit-breaker. It includes the voltage shift of the neutral of a polyphase circuit.

[SOURCE: IEC 60050-441:1984, 441-17-26, modified –Note 2 has been deleted.]

3.5.8.2

power-frequency recovery voltage

recovery voltage after the transient voltage phenomena have subsided

[SOURCE: IEC 60050-441:1984, 441-17-27]

3.5.9

opening time

time measured from the instant at which, the circuit-breaker being in the closed position, the current in the main circuit reaches the operating value of the overcurrent release to the instant when the arcing contacts have separated in all poles

Note 1 to entry: The opening time is commonly referred to as tripping time, although, strictly speaking, tripping time applies to the time between the instant of initiation of the opening time and the instant at which the opening command becomes irreversible.

3.5.10

arcing time

3.5.10.1

arcing time of a pole

interval of time between the instant of initiation of the arc in a pole and the instant of final arc extinction in that pole

[SOURCE: IEC 60050-441:1984, 441-17-37, modified – “or a fuse” and "or that fuse" have been deleted.]

3.5.10.2

arcing time of a multipole circuit-breaker

interval of time between the instant of first initiation of an arc and the instant of final extinction in all poles

[SOURCE: IEC 60050-441:1984, 441-17-38]

3.5.11

break time

interval of time between the beginning of the opening time of a circuit-breaker and the end of the arcing time

3.5.12

I^2t

Joule integral

integral of the square of the current over a given time interval

$$I^2t = \int_{t_0}^{t_1} i^2 dt$$

3.5.13

I^2t characteristic of a circuit-breaker

curve giving the maximum values of I^2t as a function of the prospective current under stated conditions of operation

3.5.14

co-ordination between overcurrent protective devices in series

3.5.14.1

overcurrent protective co-ordination of overcurrent protective devices

co-ordination of two or more overcurrent protective devices in series to ensure overcurrent selectivity) and/or back-up protection

[SOURCE: IEC 60947-1:2007, 2.5.22]

3.5.14.2

overcurrent selectivity

co-ordination of the operating characteristics of two or more overcurrent protective devices in series such that, on the incidence of overcurrents within stated limits, the device intended to operate within these limits does so, while the other(s) does (do) not

[SOURCE: IEC 60947-2:2006/AMD2:2013, 2.17.1]

3.5.14.3

back-up protection

overcurrent co-ordination of two overcurrent protective devices in series, where the protective device, generally but not necessarily on the supply side, effects the overcurrent protection with or without the assistance of the other protective device and prevents excessive stress on the latter

[SOURCE: IEC 60947-1:2007, 2.5.24]

3.5.14.4

total selectivity

overcurrent selectivity where, in the presence of two overcurrent protective devices in series, the protective device on the load side effects the protection without causing the other protective device to operate

[SOURCE: IEC 60947-2:2006, 2.17.2]

3.5.14.5

partial selectivity

overcurrent selectivity where, in the presence of two overcurrent protective devices in series, the protective device on the load side effects the protection up to a given level of overcurrent, without causing the other protective device to operate

[SOURCE: IEC 60947-2:2006, 2.17.3]

3.5.14.6

selectivity limit current

I_s

current co-ordinate of the intersection between the total time-current characteristic of the protective device on the load side and the pre-arcing (for fuses), or tripping (for circuit-breakers) time-current characteristic of the other protective device

Note 1 to entry: The selectivity limit current (see Figure D.1) is a limiting value of current

- below which, in the presence of two overcurrent protective devices in series, the protective device on the load side completes its breaking operation in time to prevent the other protective device from starting its operation (i.e. selectivity is ensured);
- above which, in the presence of two overcurrent protective devices in series, the protective device on the load side may not complete its breaking operation in time to prevent the other protective device from starting its operation (i.e. selectivity is not ensured)

[SOURCE: IEC 60947-2:2006, 2.17.4]

3.5.14.7

take-over current

I_B

current co-ordinate of the intersection between the time-current characteristics of two overcurrent protective devices

Note 1 to entry: The take-over current is the current co-ordinate of the intersection between the maximum break-time / current characteristics of two overcurrent protective devices in series.

[SOURCE: IEC 60050-441:1984, 441-17-16]

3.5.14.8

conditional short-circuit current (of a circuit or a switching device)

prospective current that a circuit or a switching device, protected by a specified short-circuit protective device, can satisfactorily withstand for the total operating time of that device under specified conditions of use and behaviour

Note 1 to entry: For the purpose of this standard, the short-circuit protective device is generally a circuit-breaker or a fuse.

Note 2 to entry: This definition differs from IEC 60050-441:1984, 441-17-20 by broadening the concept of current limiting device into a short-circuit protective device, the function of which is not only to limit the current.

[SOURCE: IEC 60947-1:2007, 2.5.29]

3.5.14.9

rated conditional short-circuit current

I_{nc}

value of prospective current, stated by the manufacturer, which the equipment, protected by a short-circuit protective device specified by the manufacturer, can withstand satisfactorily for the operating time of this device under the test conditions in the relevant product standard

[SOURCE: IEC 60947-1:2007, 4.3.6.4]

3.5.15

conventional non-tripping current

I_{nt}

- Ⓒ specified value of current which the circuit-breaker is capable of carrying for a specified time designated as conventional time, without tripping

[SOURCE: IEC 60050-442:1998, 442-05-54] Ⓒ

3.5.16

conventional tripping current

I_t

specified value of current which causes the circuit-breaker to trip within a specified time (conventional time)

- Ⓒ [SOURCE: IEC 60050-441:1984, 442-05-55, modified] Ⓒ

3.5.17**instantaneous tripping current**

minimum value of current causing the circuit-breaker to operate automatically without intentional time-delay

3.6 Definitions related to insulation co-ordination**3.6.1****insulation coordination**

mutual correlation of insulation characteristics of electrical equipment taking into account the expected micro-environment and the influencing stresses

[SOURCE: IEC 60664-1:2007, 1.3.1]

3.6.2**working voltage**

highest r.m.s. value of the a.c. or d.c. voltage across any particular insulation which can occur when the equipment is supplied at rated voltage

Note 1 to entry: Transients are disregarded.

Note 2 to entry: Both open-circuit conditions and normal operating conditions are taken into account.

[SOURCE: IEC 60664-1:2007, 3.5]

3.6.3**overvoltage**

any voltage having a peak value exceeding the corresponding peak value of maximum steady-state voltage at normal operating conditions

[SOURCE: IEC 60664-1:2007, 3.7]

3.6.4**impulse withstand voltage**

highest peak value of impulse voltage of prescribed form and polarity, which does not cause breakdown of the insulation under specific conditions

[SOURCE: IEC 60664-1:2007, 3.8.1]

3.6.5**overvoltage category**

numeral defining a transient overvoltage condition

[SOURCE: IEC 60664-1:2007, 3.10, modified – The notes have been deleted.]

3.6.6**macro-environment**

environment of the room or other location, in which the equipment is installed or used

[SOURCE: IEC 60664-1:2007, 3.12.1]

3.6.7**micro-environment**

immediate environment of the insulation which particularly influences the dimensioning of the creepage distances

[SOURCE: IEC 60664-1:2007, 3.12.2]

3.6.8**pollution**

any addition of foreign matter, solid, liquid or gaseous that can result in a reduction of electric strength or surface resistivity of the insulation

[SOURCE: IEC 60664-1:2007, 3.11]

3.6.9**pollution degree**

numeral characterising the expected pollution of the micro-environment

Note 1 to entry: The pollution degree to which equipment is exposed may be different from that of the macro-environment where the equipment is located because of protection offered by means such as an enclosure or internal heating to prevent absorption or condensation of moisture.

[SOURCE: IEC 60664-1:2007, 3.13, modified – Note 1 to entry has been added.]

3.6.10**isolation****isolating function**

function intended to cut off the supply from all or a discrete section of the installation by separating the installation from every source of electrical energy for reasons of safety

[SOURCE: IEC 60947-1:2007, 2.1.19,]

3.6.11**isolating distance**

<of a pole of a mechanical switching device> clearance between open contacts, meeting the safety requirements specified for isolation purposes

[SOURCE: IEC 60050-441:1984, 441-17-35 **C**], modified **C**]

3.6.12**clearance**

shortest distance in air between two conductive parts along a string stretched the shortest way between these conductive parts (see Annex B)

Note 1 to entry: For the purpose of determining a clearance to accessible parts, the accessible surface of an insulating enclosure is considered conductive as if it was covered by a metal foil wherever it can be touched by a hand or a standard test finger according to Figure 8.

[SOURCE: IEC 60050-441:1984, 441-17-31, modified – Note 1 to entry has been added.]

3.6.13**creepage distance**

shortest distance along the surface of an insulating material between two conductive parts

Note 1 to entry: See Annex B.

Note 2 to entry: For the purpose of determining a creepage distance to accessible parts, the accessible surface of an insulating enclosure is considered conductive as if it was covered by a metal foil wherever it can be touched by a hand or a standard test finger according to Figure 8.

[SOURCE: IEC 60050-151:1984, 151-15-50 modified – Notes 1 and 2 to entry have been added.]

4 Classification

4.1 General

Circuit-breakers are classified according to several criteria.

4.2 According to the number of poles:

- single-pole circuit-breakers;
- two-pole-circuit-breakers with one protected pole;
- two-pole circuit-breakers with two protected poles;
- three-pole circuit-breakers with three protected poles;
- four-pole circuit-breakers with three protected poles;
- four-pole circuit-breakers with four protected poles.

NOTE The pole which is not a protected pole can be

- "unprotected" (see 3.2.7.2), or
- "switched neutral" (see 3.2.7.3).

4.3 According to the protection against external influences:

- enclosed-type (not requiring an appropriate enclosure);
- unenclosed-type (for use with an appropriate enclosure).

4.4 According to the method of mounting:

- surface-type;
- flush-type;
- panel board type, also referred to as distribution board type.

NOTE These types may be intended to be rail mounted.

4.5 According to the methods of connection

4.5.1 According to the fixation system:

- circuit-breakers, the electrical connections of which are not associated with the mechanical mounting;
- circuit-breakers, the electrical connections of which are associated with the mechanical mounting.

NOTE Examples of this type are:

- plug-in type;
- bolt-on type;
- screw-in type.

Some circuit-breakers can be of the plug-in type or bolt-on type on the line side only, the load terminals being usually suitable for wiring connection.

4.5.2 According to the type of terminals:

- circuit-breakers with screw-type terminals for external copper conductors;
- circuit-breakers with screwless type terminals for external copper conductors;

NOTE 1 The requirements for circuit-breakers equipped with this type of terminals are given in Annex J.

- circuit-breakers with flat quick-connect terminals for external copper conductors;

NOTE 2 The requirements for circuit-breakers equipped with this type of terminals are given in Annex K.

- circuit-breakers with screw-type terminals for external aluminium conductors;

NOTE 3 The requirements for circuit-breakers with this type of terminal are given in Annex L.

4.6 According to the instantaneous tripping current (see 3.5.17)

- B-type;
- C-type;
- D-type.

NOTE The selection of a particular type can depend on the installation rules.

4.7 According to the I^2t characteristic

Ⓒ Circuit-breakers of B-type and C-type, having rated current up to and including 63 A and having short-circuit breaking capacity of 3 000 A, 4 500 A, 6 000 A and 10 000 A, are classified according to the limits within which their I^2t characteristics lie, measured according to 9.12.6 (see Annex ZA). Ⓒ

5 Characteristics of circuit-breakers

5.1 List of characteristics

The characteristics of a circuit-breaker shall be stated in the following terms:

- number of poles (see 4.2);
- protection against external influences (see 4.3);
- method of mounting (see 4.4);
- method of connection (see 4.5);
- value of rated operational voltage (see 5.3.1);
- value of rated current (see 5.3.2);
- value of rated frequency (see 5.3.3);
- range of instantaneous tripping current (see 4.5 and 5.3.5);
- value of rated short-circuit capacity (see 5.3.4);
- I^2t characteristic (see 3.5.13);
- I^2t classification (see 4.6).

5.2 Rated quantities

5.2.1 Rated voltages

5.2.1.1 Rated operational voltage (U_e)

The rated operational voltage (hereinafter referred to as rated voltage) of a circuit-breaker is the value of voltage, assigned by the manufacturer, to which its performance (particularly the short-circuit performance) is referred.

NOTE The same circuit-breaker can be assigned a number of rated voltages and associated rated short-circuit capacities.

5.2.1.2 Rated insulation voltage (U_i)

The rated insulation voltage of a circuit-breaker is the value of voltage, assigned by the manufacturer, to which dielectric test voltages and creepage distances are referred.

Unless otherwise stated, the rated insulation voltage is the value of the maximum rated voltage of the circuit-breaker. In no case shall the maximum rated voltage exceed the rated insulation voltage.

5.2.1.3 Rated impulse withstand voltage (U_{imp})

- Ⓒ The rated impulse withstand voltage (U_{imp}) of a circuit-breaker is the value of voltage, assigned by the manufacturer, to which impulse test voltages and clearances are referred.

The rated impulse withstand voltage of a circuit-breaker shall be equal to or higher than the standard value of rated impulse withstand voltage given in 5.3.6. C

C NOTE For dimensioning of clearances, for rated impulse withstand voltages higher than the standard value of rated impulse withstand voltage given in 5.3.6, see EN 60664 series. C

5.2.2 Rated current (I_n)

A current assigned by the manufacturer as the current which the circuit-breaker is designed to carry in uninterrupted duty (see 3.2.14), at a specified reference ambient air temperature.

The standard reference ambient air temperature is 30 °C. If a different reference ambient air temperature for the circuit-breaker is used, the effect on the overload protection of cables shall be taken into account, since this is also based on a reference ambient air temperature of 30 °C according to installation rules.

C Text deleted C

5.2.3 Rated frequency

The rated frequency of a circuit-breaker is the power frequency for which the circuit-breaker is designed and to which the values of the other characteristics correspond.

The same circuit-breaker may be assigned a number of rated frequencies.

5.2.4 Rated short-circuit capacity (I_{cn})

The rated short-circuit capacity of a circuit-breaker is the value of the ultimate short-circuit breaking capacity (see 3.5.5.1) assigned to that circuit-breaker by the manufacturer.

NOTE A circuit-breaker having a given rated short-circuit capacity has a corresponding service short-circuit capacity (I_{cs}) (see C Table 18 C).

5.2.5 Rated making and breaking capacity of an individual pole (I_{cn1})

The value of the limiting short-circuit making and breaking capacity on each individual protected pole of multipole circuit breakers.

NOTE The corresponding rated quantity of RCBOs is the rated residual making and breaking capacity $I_{\Delta m}$ (see 5.2.7 of IEC 61009-1:2010).

The standard values are those given in 5.3.4.1.

5.3 Standard and preferred values

C 5.3.1 Standard values of rated voltage

Standard values of rated voltage are given in Table 1. C

C

Table 1 — Standard values of rated voltage

Circuit-breakers	Circuit supplying the circuit-breaker	Rated voltage of circuit-breakers for use in systems 230 V, 230/400 V, 400 V
Single pole	Single phase (phase to neutral or phase to phase)	230 V
	Three-phase 4-wire	230 V
Two-pole	Single phase (phase to neutral) or three-phase, using 3 singlepole circuit-breakers (3-wire or 4-wire)	230/400 V
	Single phase (phase to neutral or phase to phase)	230 V
Three-pole	Single phase (phase to phase)	400 V
	Three phase (4-wire)	230 V
	Three phase (3-wire or 4-wire)	400 V
Four-pole	Three phase (4-wire)	400 V
NOTE Wherever in this standard there is a reference to 230 V or 400 V, they may be read as 220 V or 240 V, 380 V or 415 V, respectively.		

C

C Two-pole circuit-breakers rated 230 V may have one or two protected poles. Two-pole circuit-breakers rated 400 V shall have two protected poles. Three-pole circuit-breakers shall have three protected poles. Four-pole circuit-breakers may have three or four protected poles.

C

5.3.2 Preferred values of rated current

Preferred values of rated current are:

6 A, 8 A, 10 A, 13 A, 16 A, 20 A, 25 A, 32 A, 40 A, 50 A, 63 A, 80 A, 100 A and 125 A.

5.3.3 Standard values of rated frequency

Standard values of rated frequency are 50 Hz and 60 Hz.

5.3.4 Values of rated short-circuit capacity

5.3.4.1 Standard values up to and including 10 000 A

Standard values of rated short-circuit capacities up to and including 10 000 A are:

1 500 A*, 3 000 A, 4 500 A, 6 000 A, 10 000 A.

C (*) Only for circuit-breakers incorporated or associated with and in the immediate vicinity of socket-outlets or switches for household and similar applications. C

The corresponding power factor ranges are given in 9.12.5.

5.3.4.2 Standard values above 10 000 A up to and including 25 000 A

For values above 10 000 A up to and including 25 000 A the standard values are: 15 000 A, 20 000 A and 25 000 A.

The corresponding power factor range is given in 9.12.5.

5.3.5 Standard ranges of instantaneous tripping

Standard ranges of instantaneous tripping are given in Table 2.

Table 2 – Ranges of instantaneous tripping

Type	Range
B	Above $3 I_n$ up to and including $5 I_n$
C	Above $5 I_n$ up to and including $10 I_n$
D	Above $10 I_n$ up to and including $20 I_n$
Text deleted	

5.3.6 Standard value of rated impulse withstand voltage (U_{imp})

The standard value of the rated impulse withstand voltage (U_{imp}) is 4 kV.

Table 3 (void)

Text deleted

6 Marking and other product information**6.1 Standard marking**

Each circuit-breaker shall be marked in a durable manner with the following:

- manufacturer's name or trade mark;
- type designation, catalogue number or serial number;
- rated voltage(s);
- rated current without symbol "A", preceded by the symbol of instantaneous tripping (B, C or D), for example B 16;
- rated frequency if the circuit-breaker is designed only for one frequency (see 5.3.3);
- rated short-circuit capacity, in A, within a rectangle, without symbol "A";
- wiring diagram, unless the correct mode of connection is evident;
- reference calibration temperature, if different from 30 °C;
- degree of protection (only if different from IP20);
- void;
- void;
- making and breaking capacity on an individual protected pole of multipole circuit-breakers (I_{cn1}), if different from I_{cn} ;
- energy limiting class in a square in accordance with Annex ZA, if applied. I_{cn} and the energy limiting class, when applied, shall be both on the device and combined.

Marking d) shall be readily visible when the circuit-breaker is installed. If, for small devices, the available space is insufficient, markings a), b), c), f), g), l) and m) may be put on the side or on the back of the circuit-breaker. Marking g) alternatively may be on the inside of any cover which has to be removed in order to connect the supply wires but shall not be on a label loosely attached to the circuit-breaker. Any other information not marked shall be given in the manufacturer's documentation.

The suitability for isolation, which is provided by all circuit-breakers of this standard, may be indicated by the symbol  (IEC 60417-6169-1) on the device. When affixed, this marking may be included in a wiring diagram, where it may be combined with symbols of other functions, e.g. overload protection, or other symbols of IEC 60417. When the symbol is used on its own (i.e. not in a wiring diagram), combination with symbols of other functions is not allowed.

Irrespective of type (B, C or D), the manufacturer shall publish in his literature the I^2t characteristic (see 3.5.13).

The manufacturer may indicate the I^2t classification (see 4.7) and mark the circuit-breakers accordingly.

For circuit-breakers other than those operated by means of push-buttons the open position shall be indicated by the symbol O (a circle) IEC 60417-5008 and the closed position by the symbol I (a short vertical straight line) IEC 60417-5007. Additional national symbols for this indication are allowed. Provisionally the use of this national indication alone is allowed. These indications shall be readily visible when the circuit-breaker is installed.

For circuit-breakers operated by means of two push-buttons, only the push-button designed for the opening operation shall be red and/or be marked with the symbol O (IEC 60417-5008).

Red shall not be used for any other push-button of the circuit-breaker.

If a push-button is used for closing the contacts and is clearly identified as such, its depressed position is sufficient to indicate the closed position.

If a single push-button is used for closing and opening the contacts and is identified as such, the button remaining in its depressed position is sufficient to indicate the closed position. On the other hand, if the button does not remain depressed, an additional means indicating the position of the contacts shall be provided.

For circuit-breakers with multiple current ratings, the maximum value shall be marked in accordance with marking d), and in addition the value for which the circuit-breaker is adjusted shall be indicated without ambiguity.

If it is necessary to distinguish between the supply and the load terminals, the former shall be indicated by arrows pointing towards the circuit-breaker and the latter by arrows pointing away from the circuit-breaker.

Terminals intended exclusively for the neutral shall be indicated by the letter N.

Terminals intended for the protective conductor, if any, shall be indicated by the symbol  (IEC 60417-5019).

NOTE The symbol , (IEC 60417-5017), previously recommended, will be progressively superseded by the preferred symbol IEC 60417-5019 given above.

For rail mounting circuit-breakers, appropriate rail(s) shall be indicated in manufacturer's documentation.

Marking shall be indelible and easily legible, and shall not be placed on screws, washers or other removable parts.

Compliance is checked by inspection and by the test of 9.3.

6.2 Additional marking

Additional marking to other standards (EN or IEC or other) is allowed under the following conditions:

- the circuit-breaker shall comply with all the requirements of the additional standard;
- the relevant standard to which the additional marking refers shall be indicated adjacent to this marking and shall be clearly differentiated or separated from the standard marking according to 6.1.

Compliance is checked by inspection and by carrying out all the test sequences required by the relevant standard. Equivalent or less severe test sequences need not be repeated.

6.3 Guidance table for marking

Marking and other product information		Markings may be on the MCB itself			Product information in catalogue
Each MCB shall be marked in a durable manner with all or, for small apparatus, part of the following data:		If, for small devices the space available does not allow all the above data to be marked, at least this information shall be marked and visible when the device is installed	This information may be marked on the side or on the back of the device and be visible only before the device is installed.	Alternatively the information may be on the inside of any cover which has to be removed in order to connect the supply wires.	Any remaining information not marked shall be given in the manufacturer's catalogues .
a)	manufacturer's name or trademark		X		
b)	type designation, catalogue number or serial number		X		
c)	rated voltage, with the symbol ~		X		
d)	rated current without symbol "A" preceded by the symbol of overcurrent instantaneous tripping (B, C or D), for example B 16	X			
e)	rated frequency if the circuit-breaker is designed only for one frequency (see 5.3.3)				X
f)	rated short-circuit capacity in a rectangle, in amperes, without symbol "A"		X(*)		
g)	wiring diagram, unless the correct mode of connection is evident		X	X	
h)	reference calibration temperature, if different from 30 °C				X
i)	the degree of protection (only if different from IP20)				X
j)	void				
k)	void				

l)	breaking capacity on one pole of multipole MCBs in case of shortcircuit to earth I_{cn1}		X		
m)	energy limiting class (e.g. 3) in a square in accordance with Annex ZA, as applicable		X(*)		X(**)
	the position of use (symbol according to EN 60051), if necessary;		X		
	indication of the terminal for the neutral with "N"		X		
	additional marking of performance to other standards		X		
(*) I_{cn} and the energy limiting class, as applicable, shall be both on the device and combined together. (**) The manufacturer shall publish in his literature the I^2t characteristic.					



7 Standard conditions for operation in service and for installation

7.1 Standard conditions

Circuit-breakers complying with this standard shall be capable of operating under the standard conditions shown in Table Z.1.

Table Z.1 – Standard conditions for operation in service

Influencing quantity	Standard range of application	Reference value	Test tolerances ^f
Ambient temperature ^{a,g}	–5 °C to +40 °C ^b	see 9.2	
Altitude	Not exceeding 2 000 m		
Relative humidity maximum value 40 °C	50 % ^c		
External magnetic field	Not exceeding 5 times the earth's magnetic field in any direction	Earth's magnetic field	^d
Position	As stated by the manufacturer, with a tolerance of 2° in any direction ^e	As stated by the manufacturer	2° in any direction
Frequency	Reference value ± 5 % ^f	Rated value	± 5 %
Sinusoidal wave distortion	Not exceeding 5 %	Zero	Zero

^a The maximum value of the mean daily temperature is +35 °C.

^b Values outside the range are admissible where more severe climatic conditions prevail, subject to agreement between manufacturer and user.

^c Higher relative humidities are admitted at lower temperature (for example 90 % at 20 °C).

^d When a circuit-breaker is installed in proximity of a strong magnetic field, supplementary requirements may be necessary.

^e The device shall be fixed without causing deformation liable to impair its functions.

^f The tolerances given apply unless otherwise specified in the relevant test.

^g Extreme limits of –20 °C and +60 °C are admissible during storage and transportation, and should be taken into account in the design of the device.

7.2 Conditions of installation

Circuit-breakers shall be installed in accordance with the manufacturer's instructions. C

8 Requirements for construction and operation

8.1 Mechanical design

8.1.1 General

Circuit-breakers shall be so designed and constructed that, in normal use, their performance is reliable and without danger to the user or surroundings.

In general, compliance is checked by carrying out all the relevant tests specified.

8.1.2 Mechanism

The moving contacts of all poles of multipole circuit-breakers shall be so mechanically coupled that all poles, except the switched neutral, if any, make and break substantially together, whether operated manually or automatically, even if an overload occurs on one protected pole only.

The switched neutral pole (see 3.2.7.3) of four-pole circuit-breakers shall not close after and shall not open before the protected poles.

Compliance is checked by inspection and by manual test, using any appropriate means (e.g. indicator lights, oscilloscope, etc.).

If a pole having an appropriate short-circuit making and breaking capacity is used as a neutral pole and the circuit-breaker has an independent manual operation (see 3.4.4), then all poles, including the neutral pole, may operate substantially together.

Circuit-breakers shall have a trip-free mechanism.

Compliance with the above requirements is checked by inspection, by manual test and, for the trip-free function, by the test of 9.10.3.

It shall be possible to switch the circuit-breaker on and off by hand. C For plug-in type circuit-breakers, this requirement is not considered met by the fact that the circuit-breaker can be removed from its base. C

Circuit-breakers shall be so constructed that the moving contacts can come to rest only in the closed position (see 3.2.8) or in the open position (see 3.2.9), even when the operating means is released in an intermediate position.

Circuit-breakers shall provide in the open position (see 3.2.9) an isolation distance in accordance with the requirements necessary to satisfy the isolating function (see 8.3). Indication of the open and closed position of the main contacts shall be provided by one or both of the following means:

- the position of the actuator (this being preferred), or
- a separate mechanical indicator.

If a separate mechanical indicator is used to indicate the position of the main contacts, this shall show the colour red for the closed position (ON) and the colour green for the open position (OFF).

The means of indication of the contact position shall be reliable.

Compliance is checked by inspection and by the tests of 9.10.3.

Circuit-breakers shall be designed so that the actuator, front plate or cover can only be correctly fitted in a manner which ensures correct indication of the contact position.

Compliance is checked by inspection and by the tests of 9.12.12.1 and 9.12.12.2.

Where the operating means is used to indicate the position of the contacts, the operating means, when released, shall automatically take up the position corresponding to that of the moving contact(s); in this case, the operating means shall have two distinct rest positions corresponding to the position of the contacts but, for automatic opening, a third distinct position of the operating means may be provided.

The action of the mechanism shall not be influenced by the position of enclosures or covers and shall be independent of any removable part.

A cover sealed in position by the manufacturer is considered to be a non-removable part.

If the cover is used as a guiding means for push-buttons, it shall not be possible to remove the buttons from the outside of the circuit-breaker.

Operating means shall be securely fixed on their shafts and it shall not be possible to remove them without the aid of a tool. Operating means directly fixed to covers are allowed.

If the operating means has an "up-down" movement, when the circuit-breaker is mounted as in normal use, the contacts shall be closed by the up movement.

☐ Text deleted ☐

Compliance is checked by inspection and by manual test.

When means are provided or specified by the manufacturer to lock the operating means in the open position, locking in that position shall only be possible when the main contacts are in the open position.

NOTE Locking of the operating means in the closed position is possible for particular applications.

Compliance is checked by inspection, taking into account the instructions of the manufacturer.

☐ 8.1.3 Clearances and creepage distances

8.1.3.1 General

The minimum required clearances and creepage distances are given in Table 4 that is based on the circuit-breaker being designed for operating in an environment with pollution degree 2.

The insulating materials are classified into material groups on the basis of their comparative tracking index (CTI) according to EN 60664-1.

NOTE 1 The comparative tracking index (CTI) is declared by the manufacturer on the basis of tests carried out on the insulating material.

NOTE 2 Information on the requirements for design of solid insulation is provided in EN 60664-1.

Table 4 — Minimum clearances and creepage distances

	Minimum clearances mm	Minimum creepage distances ^{e, f}											
		Group IIIa ^h (175 V ≤ CTI < 400 V) ^d				Group II (400 V ≤ CTI < 600 V) ^d				Group I (600 V ≤ CTI) ^d			
	Rated voltage V	Working voltage ^e V											
	U_{imp} 4 kV												
Item/Description	230/400 230 400	> 25 ≤ 50 ⁱ	120	250	400	> 25 ≤ 50 ⁱ	120	250	400	> 25 ≤ 50 ⁱ	120	250	400
1. between live parts which are separated when the main contacts are in the open position ^{a, j}	4,0	1,2	2,0	4,0	4,0	0,9	2,0	4,0	4,0	0,6	2,0	4,0	4,0
2. between live parts of different polarity ^{a, j, k}	3,0	1,2	1,5	3,0	4,0	0,9	1,5	3,0	3,0	0,6	1,5	3,0	3,0
3. between circuits supplied from different sources, one of which being PELV or SELV ^g	8,0		3,0	6,0	8,0		3,0	6,0	8,0		3,0	6,0	8,0
		Rated voltage V											
		230 / 400				230 / 400				230 / 400			
4. between live parts and – accessible surfaces of operating means – screws or other means for fixing covers which have to be removed when mounting the circuit-breaker – surface on which the circuit-breaker is mounted ^p – screws or other means for fixing the circuit-breaker ^p – metal covers or boxes ^b – other accessible metal parts ^c – metal frames supporting flushtype circuit-breakers	3,0	4,0				3,0				3,0			

NOTE 1 The values given for 400 V are also valid for 440 V.

NOTE 2 The parts of the neutral path, if any, are considered to be live parts.

^a For auxiliary and control contacts the values are given in the relevant standard.

^b The values are doubled if clearances and creepage distances between live parts of the device and the metallic screen or the surface on which the circuit-breaker is mounted are not dependent on the design of the circuit-breaker only, so that they can be reduced when the circuit-breaker is mounted in the most unfavourable condition.

^c Including a metal foil in contact with the surfaces of insulating material which are accessible after installation for normal use. The foil is pushed into corners, grooves, etc., by means of a straight unjointed test finger according to 9.6 (see Figure 8).

^d See EN 60112.

^e Interpolation is allowed in determining creepage distances corresponding to voltage values intermediate to those listed as working voltage. When interpolating, linear interpolation shall be used and values shall be rounded to the same number of digits as the values picked up from the tables. For determination of creepage distances, see Annex B.

^f Creepage distances cannot be less than the associated clearances.

^g To cover all different voltages including ELV in an auxiliary contact.

^h For material group IIIb (100 V ≤ CTI < 175 V) the values for material group IIIa multiplied by 1,6 apply.

ⁱ For working voltages up to and including 25 V reference may be made to EN 60664-1.

^j The clearance distances between the metal parts within the arc chamber may be less than 1 mm, provided that the sum of distances is greater than prescribed in item 1 of Table 4.

^k This applies also to clearance and creepage distances between live parts of different polarity of circuit-breakers mounted close to one another.

8.1.3.2 Clearances

Compliance for item 1 in Table 4 is checked by measurement and by the tests of 9.7.5.4.

Compliance for item 2 and 4 in Table 4 is checked by measurement or by the tests of 9.7.5.2.

The clearances of items 2 and 4 (except accessible surface after installation, see Note) may be reduced provided that the measured clearances are not shorter than the minimum allowed in IEC 60664-1 for homogenous field conditions.

In this case, compliance for items 2 and 4 is always checked by the test of 9.7.5.2.

NOTE Accessible surface after installation means any surface accessible by the user when the circuit-breaker is installed according to the manufacturer's instructions. The test finger can be applied to determine whether a surface is accessible or not.

Compliance for item 3 in Table 4 is checked by measurement.

8.1.3.3 Creepage distances

Compliance for item 1, 2, 3 and 4 is checked by measurement

NOTE All measurements required in 8.1.3 are carried out in Test sequence A on one sample. Tests according to 9.7.2 to 9.7.5 are carried out in Test sequence B on three samples.

8.1.3.4 Solid insulation

Compliance is checked by the tests according to 9.7.2, 9.7.3, 9.7.4 and 9.7.5 as applicable. 

8.1.4 Screws, current-carrying parts and connections

8.1.4.1 Connections, whether electrical or mechanical, shall withstand the mechanical stresses occurring in normal use.

Screws operated when mounting the circuit-breaker during installation shall not be of the thread-cutting type.

NOTE 1 Screws (or nuts) which are operated when mounting the circuit-breaker include screws for fixing covers or cover-plates, but not connecting means for screwed conduits and for fixing the base of a circuit-breaker.

Compliance is checked by inspection and by the test of 9.4.

NOTE 2 Screwed connections are considered as checked by the tests of 9.8, 9.9, 9.12, 9.13 and 9.14.

8.1.4.2 For screws in engagement with a thread of insulating material and which are operated when mounting the circuit-breaker during installation, correct introduction of the screw into the screw hole or nut shall be ensured.

Compliance is checked by inspection and by manual test.

The requirement with regard to correct introduction is met, if introduction of the screw in a slanting manner is prevented, for example by guiding the screw by the part to be fixed by a recess in the female thread, or by the use of a screw with the leading thread removed.

8.1.4.3 Electrical connections shall be so designed that contact pressure is not transmitted through insulating material other than ceramic, pure mica or other material with characteristics no less suitable, unless there is sufficient resilience in the metallic parts to compensate for any possible shrinkage or yielding of the insulating material.

Compliance is checked by inspection.



NOTE The suitability of the material is considered in respect of the stability of the dimensions.

8.1.4.4 Current-carrying parts including parts intended for protective conductors, if any, shall be made of a metal having, under the conditions occurring in the equipment, mechanical strength, electrical conductivity and resistance to corrosion adequate for their intended use.

EXAMPLE Examples of suitable materials are given below:

- copper;
- an alloy containing at least 58 % copper for parts worked cold, or at least 50 % copper for other parts;
- other metal or suitably coated metal, no less resistant to corrosion than copper and having mechanical properties no less suitable.

In case of using ferrous alloys or suitably coated ferrous alloys, compliance to resistance to corrosion is checked by a test of resistance to rusting (see 9.16).

The requirements of this subclause do not apply to contacts, magnetic circuits, heater elements, bimetals, shunts,  electronic parts, including circuit boards,  or to screws, nuts, washers, clamping plates, similar parts of terminals and parts of the test circuit.

 *Compliance is checked by inspection in accordance with manufacturer's declaration.* 

8.1.5 Terminals for external conductors

8.1.5.1 Terminals for external conductors shall be such that the conductors may be connected so as to ensure that the necessary contact pressure is maintained permanently.

Connection arrangements intended for busbar connection are admissible, provided they are not used for the connection of cables.

Such arrangements may be either of the plug-in or of the bolt-on type.

The terminals shall be readily accessible under the intended conditions of use.

Compliance is checked by inspection, by the tests of 9.5 for screw-type terminals, by specific tests for plug-in or bolt-on circuit-breakers included in the standard, or by the tests of Annex J or K, as relevant for the type of connection.

8.1.5.2 Circuit breakers shall be provided with:

- either terminals which shall allow the connection of copper conductors having nominal cross-sectional areas as shown in Table 5;

NOTE Examples of possible designs of screw-type terminals are given in Annex F.

- or terminals for external untreated aluminium conductors and with aluminium screw-type terminals for use with copper or with aluminium conductors according to Annex L.

Compliance is checked by inspection, by measurement and by fitting, in turn, one conductor of the smallest and one of the largest cross-sectional area as specified.

Table 5 – Connectable cross-sections of copper conductors for screw-type terminals

Rated current ^b A		Range of nominal cross-section to be clamped ^a mm ²			
Greater than	Up to and including	Rigid (solid or stranded ^c) conductors		Flexible conductors	
–	13	1	to	2,5	1 to 2,5
13	16	1	to	4	1 to 4
16	25	1,5	to	6	1,5 to 6
25	32	2,5	to	10	2,5 to 6
32	50	4	to	16	4 to 10
50	80	10	to	25	10 to 16
80	100	16	to	35	16 to 25
100	125	25	to	50	25 to 35

^a It is required that, for current ratings up to and including 50 A, terminals be designed to clamp solid conductors as well as rigid stranded conductors. Nevertheless, it is permitted that terminals for conductors having cross-sections from 1 mm² up to 6 mm² be designed to clamp solid conductors only.

^b A range of CBs having the same fundamental design and having the same design and construction of terminals, the terminals are fitted with copper conductors of the smallest cross-section for the minimum rated current and largest cross-section for the maximum rated current, as specified, solid and stranded, as applicable.

^c Rigid stranded conductors shall be used for conductors having cross-sections from 1,5 mm² up to 50 mm² and shall be in compliance with class 2 of IEC 60228:2004, related to stranded conductors for single-core.

☐ Text deleted ☐

8.1.5.3 The means for clamping the conductors in the terminals shall not serve to fix any other component, although they may hold the terminals in place or prevent them from turning.

Compliance is checked by inspection and by the tests of 9.5.

8.1.5.4 Terminals for rated currents up to and including 32 A shall allow the conductors to be connected without special preparation.

Compliance is checked by inspection.

NOTE The term "special preparation" covers soldering of the wire of the conductor, use of cable lugs, formation of eyelets, etc., but not the reshaping of the conductor before its introduction into the terminal or the twisting of a flexible conductor to consolidate the end.

8.1.5.5 Terminals shall have adequate mechanical strength. Screws and nuts for clamping the conductors shall have a metric ISO thread or a thread comparable in pitch and mechanical strength.

Compliance is checked by inspection and by the tests of 9.4 and 9.5.2.

NOTE Provisionally, SI, BA and UN threads can be used as they are virtually equivalent in pitch and mechanical strength to metric ISO threads.

8.1.5.6 Terminals shall be so designed that they clamp the conductor without undue damage to the conductor.

Compliance is checked by inspection and by the test of 9.5.3.

8.1.5.7 Terminals shall be so designed that they clamp the conductor reliably and between metal surfaces.

Compliance is checked by inspection and by the tests of 9.4 and 9.5.2.

8.1.5.8 Terminals shall be so designed or positioned that neither a rigid solid conductor nor a wire of a stranded conductor can slip out while the clamping screws or nuts are tightened.

This requirement does not apply to lug terminals.

Compliance is checked by the test of 9.5.4.

8.1.5.9 Terminals shall be so fixed or located that, when the clamping screws or nuts are tightened or loosened, the terminals shall not work loose from their fixings to circuit-breakers.

NOTE 1 These requirements do not imply that the terminals are so designed that their rotation or displacement is prevented, but any movement is to be sufficiently limited so as to prevent non-compliance with the requirements of this standard.

NOTE 2 The use of sealing compound or resin is considered to be sufficient for preventing a terminal from working loose, provided that

- the sealing compound or resin is not subject to stress during normal use, and
- the effectiveness of the sealing compound or resin is not impaired by temperatures attained by the terminal under the most unfavourable conditions specified in this standard.

Compliance is checked by inspection, by measurement and by the test of 9.4.

8.1.5.10 Clamping screws or nuts of terminals intended for the connection of protective conductors shall be adequately secured against accidental loosening.

Compliance is checked by manual test.

NOTE In general, the designs of terminals (examples of which are shown in Annex F) can provide sufficient resilience to comply with this requirement; for other designs, special provisions, such as the use of an adequately resilient part which is not likely to be removed inadvertently, can be necessary.

8.1.5.11 Pillar terminals shall allow full insertion and reliable clamping of the conductor.

Compliance is checked by inspection after a rigid conductor of the largest cross-sectional area specified for the relevant rated current in Table 5 has been fully inserted and fully clamped by applying the torques according to Table 11.

8.1.5.12 Screws and nuts of terminals intended for the connection of external conductors shall be in engagement with a metal thread and the screws shall not be of the tapping screw type.

Ⓒ *Compliance is checked by inspection.* **Ⓒ**

8.1.6 Non-interchangeability

For circuit-breakers intended to be mounted on bases forming a unit therewith (plug-in type or screw-in type) it shall not be possible, without the aid of a tool, to replace a circuit-breaker when mounted and wired as for normal use by another of the same make having a higher rated current.

Compliance is checked by inspection.

NOTE The expression "as for normal use" implies that the circuit-breaker is installed according to the manufacturer's instructions.

8.1.7 Mechanical mounting of plug-in type circuit-breakers

8.1.7.1 General

☒ The mechanical mounting of plug-in type circuit-breakers shall be reliable and have adequate stability. ☒

8.1.7.2 Plug-in type circuit-breakers, the holding in position of which does not depend solely on their plug-in connection(s)

Compliance of the mechanical mounting is checked by the relevant tests of 9.13.

8.1.7.3 Plug-in type circuit-breakers, the holding in position of which depends solely on their plug-in connection(s)

Compliance of the mechanical mounting is checked by the relevant tests of 9.13.

8.2 Protection against electric shock

Circuit-breakers shall be so designed that, when they are mounted and wired as for normal use (see note in 8.1.6), live parts are not accessible.

A part is considered to be "accessible" if it can be touched by the test finger (see 9.6).

For circuit-breakers other than those of the plug-in type, external parts, other than screws or other means for fixing covers and labels, which are accessible when the circuit-breakers are mounted and wired as for normal use, shall either be of insulating material or be lined throughout with insulating material, unless the live parts are within an internal enclosure of insulating material.

Linings shall be fixed in such a way that they are not likely to be lost during installation of the circuit-breakers. They shall have adequate thickness and mechanical strength and shall provide adequate protection at places where sharp edges occur.

Inlet openings for cables or conduits shall either be of insulating material or be provided with bushings or similar devices of insulating material. Such devices shall be reliably fixed and shall have adequate mechanical strength.

For plug-in circuit-breakers, external parts other than screws or other means for fixing covers, which are accessible in normal conditions of use, shall be of insulating material.

Metallic operating means shall be insulated from live parts and their exposed conductive parts shall be covered by insulating material. This requirement does not apply to means for coupling insulated operating means of several poles.

It shall be possible to replace plug-in circuit-breakers easily without touching live parts.

Lacquer or enamel are not considered to provide adequate insulation for the purpose of this subclause.

Compliance is checked by inspection and by the test of 9.6.

8.3 Dielectric properties and isolating capability

8.3.1 General

Circuit-breakers shall have adequate dielectric properties and shall ensure isolation.

8.3.2 Dielectric strength at power frequency

Circuit-breakers shall have adequate dielectric properties at power frequency.

Compliance is checked by the tests of 9.7.1, 9.7.2 and 9.7.3 on the circuit-breaker in new condition.

Moreover, after the endurance tests of 9.11 and after the short-circuit tests of 9.12, the circuit-breakers shall withstand the test of 9.7.3 but at the reduced test voltage specified in 9.11.3 and 9.12.12.2 respectively and without the previous humidity treatment of 9.7.1.

8.3.3 Isolating capability

Circuit-breakers shall be suitable for isolation.

Compliance is checked by the verification of compliance with the minimum clearances and creepage distances of item 1 of Table 4 and by the tests of 9.7.5.1 and 9.7.5.3.

8.3.4 Dielectric strength at rated impulse withstand voltage (U_{imp})

Circuit-breakers shall adequately withstand impulse voltages.

Compliance is checked by the tests of 9.7.5.2.

8.4 Temperature-rise

8.4.1 Temperature-rise limits

The temperature rises of the parts of a circuit-breaker specified in Table 6, measured under the conditions specified in 9.8.2, shall not exceed the limiting values stated in that table.

The circuit-breaker shall not suffer damage impairing its functions and its safe use.

Table 6 – Temperature-rise values

Parts ^{a b}	Temperature-rise K
Terminals for external connections ^c	60
External parts liable to be touched during manual operation of the circuit-breaker, including operating means of insulating material and metallic means for coupling insulated operating means of several poles	40
External metallic parts of operating means	25
Other external parts, including that face of the circuit-breaker in direct contact with the mounting surface	60
^a No value is specified for the contacts, since the design of most circuit-breakers is such that a direct measurement of the temperature of those parts cannot be made without the risk of causing alterations or displacements of parts likely to affect the reproducibility of the tests. The 28-day test (see 9.9) is considered to be sufficient for checking indirectly the behaviour of the contacts with respect to undue overheating in service.	
^b No value is specified for parts other than those listed, but no damage shall be caused to adjacent parts of insulating materials, and the operation of the circuit-breaker shall not be impaired.	
^c For plug-in type circuit-breakers, the terminals of the base on which they are installed.	

8.4.2 Ambient air temperature

The temperature-rise limits given in Table 6 are applicable only if the ambient air temperatures remain between the limits given in 7.2.

8.5 Uninterrupted duty

Circuit-breakers shall operate reliably even after long service.

Compliance is checked by the test of 9.9.

8.6 Automatic operation

8.6.1 Standard time-current zone

The tripping characteristic of circuit-breakers shall be such that they ensure adequate protection of the circuit, without premature operation.

The zone of the time-current characteristic (tripping characteristic) of a circuit-breaker is defined by the conditions and the values stated in Table 7.

This table refers to a circuit-breaker mounted in accordance with the reference conditions (see 9.2) operating at the reference calibration temperature of 30 °C, with a tolerance of ${}^{+5}_{0}\text{ }^{\circ}\text{C}$.

Compliance is checked by the tests specified in 9.10.

The test may be made at any convenient temperature, the results being referred to 30 °C, using the information given by the manufacturer.

In any case the variation from the test current of Table 7 shall not exceed 1,2 %/ per K of calibration temperature variation.

If the circuit-breakers are marked for a calibration temperature different from 30 °C, they are tested for that different temperature.

The manufacturer shall be prepared to give information on the variation of the tripping characteristic for calibration temperatures differing from the reference value.

Table 7 – Time-current operating characteristics

Test	Type	Test current	Initial condition	Limits of tripping or non-tripping time	Result to be obtained	Remarks
a	B, C, D	$1,13 I_n$	Cold ^a	$t \leq 1$ h (for $I_n \leq 63$ A) $t \leq 2$ h (for $I_n > 63$ A)	No tripping	
b	B, C, D	$1,45 I_n$	Immediately following test a	$t < 1$ h (for $I_n \leq 63$ A) $t < 2$ h (for $I_n > 63$ A)	Tripping	Current steadily increased within 5 s
c	B, C, D	$2,55 I_n$	Cold ^a	$1 \text{ s} < t < 60 \text{ s}$ (for $I_n \leq 32$ A) $1 \text{ s} < t < 120 \text{ s}$ (for $I_n > 32$ A)	Tripping	
d	B C D	$3 I_n$ $5 I_n$ $10 I_n$	Cold ^a	$0,1 \text{ s} < t < 45 \text{ s}$ (for $I_n \leq 32$ A) $0,1 \text{ s} < t < 90 \text{ s}$ (for $I_n > 32$ A) $0,1 \text{ s} < t < 15 \text{ s}$ (for $I_n \leq 32$ A) $0,1 \text{ s} < t < 30 \text{ s}$ (for $I_n > 32$ A) $0,1 \text{ s} < t < 4 \text{ s}^b$ (for $I_n \leq 32$ A) $0,1 \text{ s} < t < 8 \text{ s}$ (for $I_n > 32$ A)	Tripping	Current established by closing an auxiliary switch
e	B C D	$5 I_n$ $10 I_n$ $20 I_n$	Cold ^a	$t < 0,1 \text{ s}$	Tripping	Current established by closing an auxiliary switch
<p>Ⓢ Text deleted Ⓢ</p> <p>^a The term "cold" means without previous loading.</p> <p>^b Ⓢ For $I_n \leq 10$ A, $t < 8$ s is permissible. Ⓢ</p>						

8.6.2 Conventional quantities

8.6.2.1 Conventional time

The conventional time is 1 h for circuit-breakers of rated current up to and including 63 A, and 2 h for circuit-breakers of rated current above 63 A.

8.6.2.2 Conventional non-tripping current (I_{nt})

The conventional non-tripping current of a circuit-breaker is 1,13 times its rated current.

8.6.2.3 Conventional tripping current (I_t)

The conventional tripping current of a circuit-breaker is 1,45 times its rated current.

8.6.3 Tripping characteristic

8.6.3.1 General

The tripping characteristic of circuit-breakers shall be contained within the zone defined in 8.6.1.

NOTE Conditions of temperature and mounting different from those specified in 9.2 (e.g. mounting in a special enclosure, grouping of several circuit-breakers in the same enclosure) can affect the tripping characteristic of circuit-breakers.

The manufacturer shall be prepared to give information on the variation of the tripping characteristic for ambient temperatures differing from the reference value, within the limits of 7.2.

8.6.3.2 Effect of single-pole loading of multipole circuit-breakers on the tripping characteristic

When circuit-breakers having more than one protected pole are loaded on only one of the protected poles, starting from cold, with a current equal to

- 1,1 times the conventional tripping current, for two-pole circuit-breakers with two protected poles,
- 1,2 times the conventional tripping current, for three-pole and four-pole circuit-breakers,

the circuit-breakers shall trip within the conventional time specified in 8.6.2.1.

Compliance is checked by the test of 9.10.4.

8.6.3.3 Effect of the ambient air temperature on the tripping characteristic

Ambient C air C temperatures other than the reference temperature, within the limits of $-5\text{ }^{\circ}\text{C}$ and $+40\text{ }^{\circ}\text{C}$, shall not unacceptably affect the tripping characteristic of circuit-breakers.

Compliance is checked by the tests of 9.10.5.

8.7 Mechanical and electrical endurance

Circuit-breakers shall be capable of performing an adequate number of cycles with rated current.

Compliance is checked by the test of 9.11.

8.8 Performance at short-circuit currents

Circuit-breakers shall be capable of performing a specified number of short-circuit operations, during which they shall neither endanger the operator nor initiate a flashover between live conductive parts or between live conductive parts and earth.

Compliance is checked by the tests of 9.12.

It is required that circuit-breakers be able to make and to break any value of current up to and including the value corresponding to the rated short-circuit capacity at rated frequency, at a power-frequency recovery voltage equal to 105 % ($\pm 5\%$) of the rated voltage and at any power factor not less than the appropriate lower limit of the range stated in 9.12.5; it is also required that the corresponding values of I^2t lie below the I^2t characteristic (see 3.5.13).

8.9 Resistance to mechanical shock and impact

Circuit-breakers shall have adequate mechanical behaviour so as to withstand the stresses imposed during installation and use.

Compliance is checked by the tests of 9.13.

8.10 Resistance to heat

Circuit-breakers shall be sufficiently resistant to heat.

Compliance is checked by the test of 9.14.

8.11 Resistance to abnormal heat and to fire

☐ Circuit-breaker ☐ parts made of insulating material shall not be likely to ignite and to spread fire if current-carrying parts in their vicinity attain a high temperature under fault or overload conditions.

☐ Compliance is checked

- for external parts made of insulating material, by the test of 9.15;
- for all other parts made of insulating material, by the test sequences, no additional test being required. ☐

8.12 Resistance to rusting

Ferrous parts shall be adequately protected against rusting.

Compliance is checked by the test of 9.16.

8.13 Power loss

Circuit-breakers shall not have excessive power loss. The maximum permissible values per pole are indicated in Table 8.

Compliance is checked by the test of 9.8.5.

Table 8 – Maximum power loss per pole

Range of rated current I_n A	Maximum power loss per pole W
$I_n \leq 10$	3
$10 < I_n \leq 16$	3,5
$16 < I_n \leq 25$	4,5
$25 < I_n \leq 32$	6
$32 < I_n \leq 40$	7,5
$40 < I_n \leq 50$	9
$50 < I_n \leq 63$	13
$63 < I_n \leq 100$	15
$100 < I_n \leq 125$	20

☐ 8.14 Electromagnetic immunity

Circuit-breakers for overcurrent protection for household and similar installations are not sensitive to normal electromagnetic disturbances and therefore no immunity tests are required.

8.15 Electromagnetic emission

Electromagnetic disturbances can only be generated by circuit-breakers for overcurrent protection for household and similar installations during occasional switching or automatic breaking operations. The duration of the disturbances is of the order of milliseconds.

The frequency, the level and the consequences of these emissions are considered as part of the normal electromagnetic environment of low voltage installations. Therefore the requirements for electromagnetic emissions are deemed to be satisfied and no verification is necessary. ☐

9 Tests

9.1 Type tests and test sequences

The characteristics of circuit-breakers are verified by means of type tests.

Type tests required by this standard are listed in Table 9.

Table 9 – List of type tests

Test	Subclause
Indelibility of marking	9.3
Reliability of screws, current-carrying parts and connections	9.4
Reliability of terminals for external conductors	9.5
Protection against electric shock	9.6
Dielectric properties and isolating capability	9.7
Temperature-rise	9.8
28-day test	9.9
Tripping characteristic	9.10
Mechanical and electrical endurance	9.11
Short-circuit	9.12
Resistance to mechanical shock and impact	9.13
Resistance to heat	9.14
Resistance to abnormal heat and to fire	9.15
Resistance to rusting	9.16

For the purpose of verification of conformity with the standard, type tests are carried out in test sequences.

The test sequences and the number of samples to be submitted are stated in Annex C.

Unless otherwise specified, each type test (or sequence of type tests) is carried out on circuit-breakers in a clean and new condition.

☐ NOTE Test to verify compliance of additional marking to 6.2, if any, are carried out according to the relevant standard. ☐

9.2 Test conditions

The circuit-breaker is mounted individually, vertically and in free air at an ambient temperature between 20 °C and 25 °C, unless otherwise specified, and is protected against undue external heating or cooling.

Circuit-breakers designed for installation in an individual enclosure are tested in the smallest of such enclosures specified by the manufacturer.

Unless otherwise specified, the circuit-breakers are wired with the appropriate cable specified in Table 10 and are fixed on a dull, black-painted plywood board of about 20 mm thickness, the method of fixing complying with any requirements relating to the means of mounting recommended by the manufacturer.

Where a tolerance is not specifically specified, type tests are carried out at values not less severe than those specified in this standard.

Unless otherwise specified, tests are carried out at the rated frequency ± 5 Hz and at any convenient voltage.

During the tests, no maintenance or dismantling of the samples is allowed.

For the tests of 9.8, 9.9, 9.10 and 9.11 the circuit-breaker is connected as follows.

- a) *The connections are made by means of single-core, PVC insulated copper cables, according to IEC 60227 series.*
- b) *Unless otherwise specified, the tests are carried out with single-phase current.*

- c) *The connections are in free air and spaced not less than the distance between the terminals.*
- d) *The minimum length of each temporary connection from terminal to terminal is:*
- *1 m for cross-sections up to and including 10 mm²;*
 - *2 m for cross-sections larger than 10 mm².*

The tightening torques to be applied to the terminal screws are two-thirds of those specified in Table 11.

Table 10 – Cross-sectional areas (S) of test copper conductors corresponding to the rated currents

S mm ²	Values of the rated current I_n A
1	$I_n \leq 6$
1,5	$6 < I_n \leq 13$
2,5	$13 < I_n \leq 20$
4	$20 < I_n \leq 25$
6	$25 < I_n \leq 32$
10	$32 < I_n \leq 50$
16	$50 < I_n \leq 63$
25	$63 < I_n \leq 80$
35	$80 < I_n \leq 100$
50	$100 < I_n \leq 125$

☐ Text deleted ☐

9.3 Test of indelibility of marking

The test is made by rubbing the marking by hand for 15 s with a piece of cotton soaked with water and again for 15 s with a piece of cotton soaked with aliphatic solvent hexane with a content of aromatics of maximum 0,1 % by volume, a kauributanol value of 29, an initial boiling-point approximately 65 °C, a dry-point of approximately 69 °C and a density of approximately 0,68 g/cm³.

Marking made by impression, moulding, or engraving is not subjected to this test.

After this test, the marking shall be easily legible.

The marking shall also remain easily legible after all the tests of this standard.

It shall not be easily possible to remove labels and they shall show no curling.

9.4 Test of reliability of screws, current-carrying parts and connections

Compliance with the requirements of 8.1.4 is checked by inspection and, for screws and nuts which are operated when mounting and connecting up the circuit-breaker, by the following test.

The screws or nuts are tightened and loosened

- *ten times for screws in engagement with a thread of insulating material;*
- *five times in all other cases.*

Screws or nuts in engagement with a thread of insulating material are completely removed and reinserted each time.

The test is made by means of a suitable test screwdriver or spanner applying a torque as shown in Table 11.

The screws and nuts shall not be tightened in jerks.

The conductor is moved each time the screw or nut is loosened.

Plug-in connections are tested by plugging the circuit-breaker in and pulling it out five times.

After the test the connections shall not have become loose nor shall their electrical function be impaired.

Table 11 – Screw thread diameters and applied torques

Nominal diameter of thread mm	Torque Nm		
	I	II	III
Up to and including 2,8	0,2	0,4	0,4
over 2,8 up to and including 3,0	0,25	0,5	0,5
over 3,0 up to and including 3,2	0,3	0,6	0,6
over 3,2 up to and including 3,6	0,4	0,8	0,8
over 3,6 up to and including 4,1	0,7	1,2	1,2
over 4,1 up to and including 4,7	0,8	1,8	1,8
over 4,7 up to and including 5,3	0,8	2,0	2,0
over 5,3 up to and including 6,0	1,2	2,5	3,0
over 6,0 up to and including 8,0	2,5	3,5	6,0
over 8,0 up to and including 10,0	3,5	4,0	10,0

Column I applies to screws without heads if the screw, when tightened, does not protrude from the hole, and to other screws which cannot be tightened by means of a screwdriver with a blade wider than the diameter of the screw.

Column II applies to other screws which are tightened by means of a screwdriver.

Column III applies to screws and nuts which are tightened by means other than a screwdriver.

Where a screw has a hexagonal head with a slot for tightening with a screwdriver and the values in columns II and III are different, the test is made twice, first applying to the hexagonal head the torque specified in column III and then, on another sample, applying the torque specified in column II by means of a screwdriver. If the values in columns II and III are the same, only the test with the screwdriver is made.

During the test, the screwed connections shall not work loose and there shall be no damage, such as breakage of screws or damage to the head slots, threads, washers or stirrups, that will impair the further use of the circuit-breaker.

Moreover, enclosures and covers shall not be damaged.

Plug-in connections are tested by plugging the circuit-breaker in and pulling it out five times.

After the test the connections shall not have become loose nor shall their electrical function be impaired.

9.5 Tests of reliability of screw-type terminals for external copper conductors

9.5.1 Compliance with the requirements of 8.1.5 is checked by inspection, by the test of 9.4, for which a rigid copper conductor having the largest cross-section specified in Table 5 is placed in the terminal (for nominal cross-sections exceeding 6 mm², a rigid stranded conductor is used; for other nominal cross-sections, a solid conductor is used), and by the tests of 9.5.2, 9.5.3 and 9.5.4.

These last tests are made using a suitable test screwdriver or spanner.

9.5.2 The terminals are fitted with copper conductors of the same type (rigid solid or rigid stranded or flexible) of the smallest and largest cross-sectional as specified in Table 5.

The terminal shall be suitable for all types of conductors of the same type (rigid – solid or stranded – or flexible), unless otherwise specified by the manufacturer.

The terminal shall be suitable for all types of conductors: rigid (solid or stranded) and flexible, unless otherwise specified by the manufacturer.

Terminals shall be tested with the minimum and maximum cross-section of each type of conductors on new terminals as follows:

- Tests for solid conductors shall use conductors having cross-sections from 1 mm² up to 6 mm², as applicable.
- Tests for stranded conductors shall use conductors having cross-sections from 1,5 mm² up to 50 mm², as applicable.
- Tests for flexible conductors shall use conductors having cross-sections from 1 mm² up to 35 mm², as applicable.

The conductor is inserted into the terminal for the minimum distance prescribed or, where no distance is prescribed, until it just projects from the far side, and in the position most likely to assist the wire to escape.

The clamping screws are then tightened with a torque equal to two-thirds of that shown in the appropriate column of Table 11.

Each conductor is then subjected to a pull of the value, in Newton, shown in Table 12. The pull is applied without jerks, for 1 min, in the direction of the axis of the conductor space.

When it is necessary, the tested values, for the different cross-sections with the relevant pulling force, shall be clearly indicated in the test report.

Table 12 – Pulling forces

Cross-section of the conductor inserted in the terminal mm ²	1 up to and including 4	Above 4 up to and including 6	Above 6 up to and including 10	Above 10 up to and including 16	Above 16 up to and including 50
Pull N	50	60	80	90	100

During the test, the conductor shall not move noticeably in the terminal.

9.5.3 The terminals are fitted with copper conductors of the smallest and largest cross-sectional areas specified in Table 5, solid or stranded, whichever is the most unfavourable,

and the terminal screws are tightened with a torque equal to two-thirds of that shown in the appropriate column of Table 11.

The terminal screws are then loosened and the part of the conductor which may have been affected by the terminal is inspected.

The conductors shall show no undue damage nor severed wires.

NOTE Conductors are considered to be unduly damaged if they show deep or sharp indentations.

During the test, terminals shall not work loose and there shall be no damage, such as breakage of screws or damage to the head slots, threads, washers or stirrups, that will impair the further use of the terminal.

9.5.4 *The terminals are fitted with the largest cross-sectional areas specified in Table 5, for rigid stranded copper conductor.*

Before insertion in the terminal, the strands of the conductor are suitably reshaped.

The conductor is inserted into the terminal until the conductor reaches the bottom of the terminal or just projects from the far side of the terminal and in the position most likely to permit a strand (or strands) to escape. The clamping screw or nut is then tightened with a torque equal to two-thirds of that shown in the appropriate column of Table 11.

After the test no strand of the conductor shall have escaped outside the retaining device.

9.6 Test of protection against electric shock

This verification is applicable to those parts of circuit breakers which are exposed to the operator when mounted as for normal use.



The test is made with the standard test finger shown in Figure 8, on the sample mounted as for normal use (see note in 8.1.6) and fitted with the conductors of the smallest and largest cross-sectional areas specified in Table 5.

The standard test finger shall be so designed that each of the jointed sections can be turned through an angle of 90° with respect to the axis of the finger, in the same direction only.

The test finger is applied in every possible bending position of a real finger, an electrical contact indicator being used to show contact with live parts.

It is recommended that a lamp be used for the indication of contact and that the voltage be not less than 40 V.

Circuit-breakers with enclosures or covers of thermoplastic material are subjected to the following additional test, which is carried out at an ambient temperature of 35 °C ± 2 °C, the circuit-breakers being at this temperature.

The circuit-breakers are subjected for 1 min to a force of 75 N, applied through the tip of a straight unjointed test finger of the same dimensions as the standard test finger.  This finger is applied to all places where yielding of insulating material could impair the safety of the circuit-breaker; in the case of knockouts it is applied with a force of 10 N. 

During this test, enclosures or covers shall not deform to such an extent that live parts can be touched with the unjointed test finger.

Unenclosed circuit-breakers having parts not intended to be covered by an enclosure are submitted to the test with a metal front panel, and mounted as for normal use (see 8.1.6).

C 9.7 Test of dielectric properties

9.7.1 Resistance to humidity

9.7.1.1 Preparation of the circuit-breaker for test

Parts which can be removed without the aid of a tool are removed and subjected to the humidity treatment with the main part; spring lids are kept open during this treatment.

Inlet openings, if any, are left open; if knockouts are provided, one of them is opened.

9.7.1.2 Test conditions

The humidity treatment is carried out in a humidity cabinet containing air with a relative humidity maintained between 91 % and 95 %.

The temperature of the air in which the sample is placed is maintained within ± 1 °C of any convenient value T between 20 °C and 30 °C.

Before being placed in the humidity cabinet, the sample is brought to a temperature between T and $T + 4$ °C.

9.7.1.3 Test procedure

The sample is kept in the cabinet for 48 h.

NOTE 1 A relative humidity between 91 % and 95 % can be obtained by placing in the humidity cabinet a saturated solution of sodium sulphate (Na_2SO_4) or potassium nitrate (KNO_3) in water having a sufficiently large contact surface with the air.

NOTE 2 In order to achieve the specified conditions within the cabinet it is necessary to ensure constant circulation of the air within and, in general, to use a cabinet which is thermally insulated.

9.7.1.4 Condition of the circuit-breaker after the test

After this treatment, the sample shall show no damage within the meaning of this standard and shall withstand the tests of 9.7.2, 9.7.3, 9.7.4, and 9.7.5.2.

9.7.2 Insulation resistance of the main circuit

The circuit-breaker having been treated as specified in 9.7.1 is then removed from the cabinet.

After an interval between 30 min and 60 min following this treatment, the insulation resistance is measured 5 s after application of a d.c. voltage of approximately 500 V, in the following order:

- a) *with the circuit-breaker in the open position, between each pair of the terminals which are electrically connected together when the circuit-breaker is in the closed position, in turn on each pole;*
- b) *with the circuit-breaker in the closed position, between each pole and the others connected together;*
- c) *with the circuit-breaker in the closed position, between all poles connected together and the frame, including a metal foil or part in contact with the outer surface of the housing of insulating material but with the terminal areas kept completely free to avoid flashover between terminals and the metal foil;*
- d) *for circuit-breakers with a metal enclosure having an internal lining of insulating material, between the frame and a metal foil in contact with the inner surface of the lining of insulating material, including bushings and similar devices.*

The measurements a), b) and c) are carried out after having connected all auxiliary circuits to the frame. The term "frame" includes:

- *all accessible metal parts and a metal foil in contact with the surfaces of insulating material which are accessible after installation as for normal use;*
- *the surface on which the base of the circuit-breaker is mounted, covered, if necessary, with a metal foil;*

- screws and other devices for fixing the base to its support;
- screws for fixing covers which have to be removed when mounting the circuit-breaker,
- metal parts of operating means referred to in 8.2.

If the circuit-breaker is provided with a terminal intended for the interconnection of protective conductors, this terminal is connected to the frame.

For the measurements according to b), c) and d), the metal foil is applied in such a way that the sealing compound, if any, is effectively tested.

The insulation resistance shall be not less than

- 2 M Ω for the measurements according to items a) and b);
- 5 M Ω for the other measurements.

9.7.3 Dielectric strength of the main circuit

After the circuit-breaker has passed the tests of 9.7.2 the test voltage specified is applied for 1 min between the parts indicated in 9.7.2.

The test voltage shall have practically sinusoidal waveform, and a frequency between 45 Hz and 65 Hz. The source of the test voltage shall be capable of supplying a short-circuit current of at least 0,2 A.

No overcurrent tripping device of the transformer shall operate when the current in the output circuit is lower than 100 mA.

The values of the test voltage shall be as follows:

- 2 000 V for items a) to c) of 9.7.2;
- 2 500 V for item d) of 9.7.2;

Initially, not more than half the prescribed voltage is applied, then it is raised to the full value within 5 s.

No flashover or breakdown shall occur during the test.

Glow discharges without drop in the voltage are neglected.

9.7.4 Insulation resistance and dielectric strength of auxiliary circuits

Insulation resistance and dielectric strength shall be verified according to a, b and c.

a) The measurement of the insulation resistance and the dielectric strength tests for the auxiliary circuits are carried out immediately after the measurement of the insulation resistance and the dielectric strength tests for the main circuit, under the conditions given in b) and c) below.

b) The measurements of the insulation resistance are carried out:

- between the auxiliary circuits connected to each other and to the frame;
- between each of the parts of the auxiliary circuits which might be isolated from the other parts in normal service and the whole of the other parts connected together, at a voltage of approximately 500 V d.c., after this voltage has been applied for 1 min.

The insulation resistance shall be not less than 2 M Ω .

c) A substantially sinusoidal voltage at rated frequency is applied for 1 min between the parts listed under b).

The voltage values to be applied are specified in Table 13

Table 13 – Test voltage of auxiliary circuits

Rated voltage of auxiliary circuits (a.c. or d.c.) V		Test voltage V
Greater than	Up to and including	
0	30	600
30	50	1000
50	110	1500
110	250	2000
250	500	2500

At the beginning of the test the voltage shall not exceed half the value specified. It is then increased steadily to the full value in not less than 5 s, but not more than 20 s.

During the test, there shall be no flashover or perforation.

NOTE 1 Discharges which do not correspond to a voltage drop are disregarded.

NOTE 2 In the case of circuit breakers in which the auxiliary circuit is not accessible for verification of the requirements given in b), the tests can be made on samples specially prepared by the manufacturer or according to his instructions.

NOTE 3 Auxiliary circuits do not include the control circuit of circuit breakers functionally dependent on line voltage.

NOTE 4 Control circuits other than those of secondary circuit of detection transformers and control circuits connected to the main circuit are submitted to the same tests as the auxiliary circuits.

9.7.5 Verification of impulse withstand voltages (across clearances and across solid insulation) and of leakage current across open contacts

9.7.5.1 General testing procedure for the impulse withstand voltage tests

The impulses are given by a generator producing positive and negative impulses having a front time of 1,2 µs, and a time to half-value of 50 µs, the tolerances being as follow:

- ± 5 % for the peak value;
- ± 30 % for the front time;
- ± 20 % for the time to half-value.

For each test, five positive impulses and five negative impulses are applied. The interval between consecutive impulses being at least 1 s for impulses of the same polarity and being at least 10 s for impulses of the opposite polarity

When performing the impulse voltage test on complete circuit-breaker, the attenuation or amplification of the test voltage shall be taken into account. It needs to be ensured that the required value of the test voltage is applied across the terminals of the equipment under test.

The surge impedance of the test apparatus shall have a nominal value of 500 Ω.

In 9.7.5.2, for the verification of clearances within the basic insulation, on complete circuit-breaker, a very low impedance of the generator is needed for the test. For this purpose, a hybrid generator with a virtual impedance of 2 ohm is appropriate if internal components are not disconnected before testing. However, in any case, a measurement of the correct test voltage directly at the clearance is required.

The shape of the impulses is adjusted with the circuit-breaker under test connected to the impulse generator. For this purpose appropriate voltage dividers and voltage sensors shall be used.

Small oscillations in the impulses are allowed provided that their amplitude near the peak of the impulse is less than 5 % of the peak value.

For oscillations on the first half of the front, amplitudes up to 10 % of the peak value are allowed.

There shall be no disruptive discharge (sparkover, flashover or puncture) during the tests.

Partial discharges in clearances which do not result in breakdown are disregarded.

NOTE The use of an oscilloscope can be necessary to observe the impulse voltage in order to detect *disruptive discharge*.

9.7.5.2 Verification of clearances with the impulse withstand voltage

If the measurement of clearances of items 2 and 4 of Table 4 does not show any reduced clearance, this test is not applied.

This test may be applied to replace measurement of clearances of items 2 and 4 of Table 4.

The test is carried out on a circuit breaker fixed on a metal support and being in the closed position.

The test impulse voltage value is given in 5.3.6. This value is corrected for barometric pressure and/or altitude at which the tests are carried out, according to Table 14.

Tests are made applying the impulse voltage between:

- a) in turn between each pole and the others connected together
- b) between all poles connected together and the frame including a metal foil or part in contact with the outer surface of the housing of insulating material but with the terminal areas kept completely free to avoid flashover between terminals and the metal foil;
- c) for circuit-breakers with a metal enclosure having an internal lining of insulating material, between the frame and a metal foil in contact with the inner surface of the lining of insulating material, including bushings and similar devices.

NOTE 1 The term "frame" is defined in 9.7.2.

Where applicable, the metal foil is applied in such a way that the sealing compound, if any, is effectively tested.

There shall be no disruptive discharge. If, however, only one such disruptive discharge occurs, ten additional impulses having the same polarity as that which caused the disruptive discharge are applied, the connections being the same as those with which the failure occurred.

No further disruptive discharge shall occur.

NOTE 2 The expression "unintentional disruptive discharge" is used to cover the phenomena associated with the failure of insulation under electric stress, which include a drop in the voltage and the flowing of current.

Table 14 — Test voltage for verification of impulse withstand voltage

Rated impulse withstand voltage U_{imp} kV	Test voltages at corresponding altitude				
	$U_{1,2/50}$ a.c. peak kV				
	Sea level	200 m	500 m	1 000 m	2 000 m
4	4,9	4,8	4,7	4,4	4,0

9.7.5.3 Verification of leakage currents across open contacts (suitability for isolation)

Each pole of circuit-breakers having been submitted to the tests of 9.12.11.2, or 9.12.11.3, or 9.12.11.4.2 or 9.12.11.4.3 or 9.12.11.4.4 is supplied at a voltage 1,1 times its rated operational voltage, the circuit-breaker being in the open position.

The leakage current flowing across the open contacts is measured and shall not exceed 2 mA.

9.7.5.4 Verification of resistance of the insulation of open contacts against an impulse voltage (suitability for isolation)

The test impulse voltage value is given in 5.3.6. These values are corrected for barometric pressure and/or altitude at which the tests are carried out, according to Table 15.

Table 15 — Test voltage for verifying the suitability for isolation, referred to the rated impulse withstand voltage of the circuit breakers and the altitude where the test is carried out

Nominal voltage of the installation V	Test voltages at corresponding altitude				
	$U_{1,2/50}$ a.c. peak kV				
	Sea level	200 m	500 m	1 000 m	2 000 m
Single and three- phase systems 230/400	6,2	6,0	5,8	5,6	5,0

The series of tests is carried out on a circuit-breaker fixed on a metal support as in normal use and with the contact in open position.

The impulses are applied between:

- the line terminals connected together;
- and the load terminals connected together with the contacts in the open position.

There shall be no disruptive discharges during the test. \square

9.8 Test of temperature-rise and measurement of power loss

9.8.1 Ambient air temperature

The ambient air temperature shall be measured during the last quarter of the test period by means of at least two thermometers or thermocouples symmetrically positioned around the circuit-breaker at about half its height and at a distance of about 1 m from the circuit-breaker.

The thermometers or thermocouples shall be protected against draughts and radiant heat.

9.8.2 Test procedure

A current equal to I_n at any convenient voltage is passed simultaneously through all the poles of the circuit-breaker for a period of time sufficient for the temperature-rise to reach the steady-state value or for the conventional time, whichever is the longer.

In practice, this condition is reached when the variation of the temperature-rise does not exceed 1 K/h.

For four-pole circuit-breakers with three protected poles, the test is first made by passing the specified current through the three protected poles only.

The test is then repeated by passing the same current through the pole intended for the connection of the neutral and the adjacent protected pole.

With the agreement of the manufacturer, the tests on four-pole circuit-breakers with three protected poles, may also be replaced by a single test with all poles in series including the N-pole.

During the test, the temperature-rises shall not exceed the values shown in table 6.

9.8.3 Measurement of the temperature of parts

The temperature of the different parts referred to in Table 6 shall be measured by means of fine wire thermocouples or by equivalent means at the nearest accessible position to the hottest spot.

Good heat conductivity between the thermocouple and the surface of the part under test shall be ensured.

9.8.4 Temperature-rise of a part

The temperature-rise of a part is the difference between the temperature of this part measured in accordance with 9.8.3, and the ambient air temperature measured in accordance with 9.8.1.

9.8.5 Measurement of power loss

An a.c. current equal to I_n , with a supply voltage of a value not less than 30 V, is passed, in a substantially resistive circuit, through each pole of the circuit-breaker.

NOTE 1 A test voltage of a value less than 30 V can be used subject to the manufacturer's agreement.

The power loss per pole, calculated on the basis of the voltage drop measured under steady state conditions between its terminals, shall not exceed the relevant values given in Table 8.

NOTE 2 The voltage drop measurement can be made during the temperature-rise test, provided that the test conditions of this subclause are fulfilled.

9.9 28-day test

The circuit-breaker is subjected to 28 cycles, each cycle comprising 21 h with a current equal to the rated current at an open circuit voltage of at least 30 V, and 3 h without current under the test conditions of 9.2.

☐ NOTE A test voltage of a value less than 30 V can be used subject to the manufacturer's agreement. ☐

The circuit-breaker is in the closed position, the current being established and interrupted by an auxiliary switch. During this test the circuit-breaker shall not trip.

During the last period of current flow the temperature-rise of the terminals shall be measured.

This temperature-rise shall not exceed the value measured during the temperature-rise test (see 9.8) by more than 15 K.

Immediately after this measurement of the temperature-rise, the current is steadily increased within 5 s to the conventional tripping current.

The circuit-breaker shall trip within the conventional time, the conventional tripping current being referred to calibration temperature, using the information given by the manufacturer.

9.10 Test of tripping characteristic

9.10.1 General

This test is made to verify that the circuit-breaker complies with the requirements of 8.6.1.

☐ If the test is made in a test chamber, it shall be made in still air; the volume of the test chamber shall be such as not to affect the test results. ☐

9.10.2 Test of time-current characteristic

9.10.2.1 *A current equal to 1,13 I_n (conventional non-tripping current) is passed for the conventional time (see 8.6.1 and 8.6.2.1) through all poles, starting from cold (see Table 7).*

The circuit-breaker shall not trip.

The current is then steadily increased within 5 s, to 1,45 I_n (conventional tripping current).

The circuit-breaker shall trip within the conventional time.

9.10.2.2 A current equal to $2,55 I_n$ is passed through all poles, starting from cold.

The opening time shall not be less than 1 s and shall not be more than

- 60 s for rated currents up to and including 32 A;
- 120 s for rated currents greater than 32 A.

9.10.3 Test of instantaneous tripping, of correct opening of the contacts and of the trip-free function

9.10.3.1 General test conditions

For the lower values of the test current of 9.10.3.2, 9.10.3.3 and 9.10.3.4 respectively the test is made once, at any convenient voltage with all poles connected in series.

For the upper values of the test current the test is made, on each protected pole, at rated voltage between phase to neutral with a power factor between 0,95 and 1.”.

The sequence of operation is

$$O - t - CO - t - CO - t - CO$$

the interval t being as defined in 9.12.11.1.

During the whole O operation the operating means is deliberately held in the closed position. The trip free function shall work properly and the tripping time of the O operation is measured. After tripping the blocked position is abandoned.

In case of circuit-breakers with dependent manual operation, the circuit-breaker shall be operated with an operating speed, during actuation, of $0,1 \text{ m/s} \pm 25 \%$, this speed being measured where and when the operating means of the test apparatus touches the operating means of the circuit-breaker under test. For rotary knobs the angular velocity shall correspond substantially to the above conditions, referred to the speed of the operating means (at its extremities) of the circuit-breaker under test.

After each operation all the indicating means shall show the open position of the contacts.

☐ The test may be performed at a convenient temperature within the range according to 7.1. ☐

9.10.3.2 For circuit-breakers of the B-type

A current equal to $3 I_n$ is passed through all poles connected in series starting from cold.

☐ The opening time shall be not less than 0,1 s and not more than:

- 45 s for rated currents up to and including 32 A,
- 90 s for rated currents above 32 A. ☐

A current equal to $5 I_n$ is then passed through each pole separately, again starting from cold.

The circuit-breaker shall trip in a time less than 0,1 s.

☐ Moreover, the circuit-breaker shall perform the test of 9.10.2.2. ☐

9.10.3.3 For circuit-breakers of the C-type

A current equal to $5 I_n$ is passed through all poles connected in series, starting from cold.

☐ The opening time shall be not less than 0,1 s and not more than:

- 15 s for rated currents up to and including 32 A,
- 30 s for rated currents above 32 A. ☐

A current equal to $10 I_n$ is then passed through each pole separately, again starting from cold.

The circuit-breaker shall trip in a time less than 0,1 s.

☐ Moreover, the circuit-breaker shall perform the test of 9.10.2.2. ☐

9.10.3.4 For circuit-breakers of the D-type

A current equal to $10 I_n$ is passed through all poles connected in series, starting from cold.

☐ The opening time shall be not less than 0,1 s and not more than:

- 4 s for rated currents above 10 A up to and including 32 A,
- 8 s for rated currents up to an including 10 A and above 32 A. ☐

☐ A current equal to $20 I_n$ is then passed through all poles, again starting from cold. ☐

The circuit-breaker shall trip in a time less than 0,1 s.

☐ Moreover, the circuit-breaker shall perform the test of 9.10.2.2. ☐

9.10.4 Test of effect of single-pole loading on the tripping characteristic of multipole circuit-breakers

Compliance is checked by testing the circuit-breaker connected in accordance with 9.2, under the conditions specified in 8.6.3.2.

The circuit-breaker shall trip within the conventional time (see 8.6.2.1).

9.10.5 Test of effect of ambient temperature on the tripping characteristic

Compliance is checked by the following tests.

- a) The circuit-breaker is placed in an ambient temperature of (35 ± 2) K below the ambient air reference temperature until it has attained steady-state temperature.

A current equal to $1,13 I_n$ (conventional non-tripping current) is passed through all poles for the conventional time. The current is then steadily increased within 5 s to $1,9 I_n$.

The circuit-breaker shall trip within the conventional time.

- b) The circuit-breaker is placed in an ambient temperature of (10 ± 2) K above the ambient air reference temperature until it has attained steady-state temperature.

A current equal to I_n is passed through all poles.

The circuit-breaker shall not trip within the conventional time.

9.11 Verification of mechanical and electrical endurance

9.11.1 General test conditions

The circuit-breaker is fixed to a metal support unless it is designed for installation in an individual enclosure, in which case it shall be mounted accordingly, as specified in 9.2.

The test is made at rated voltage, at a current adjusted to the rated current by means of resistors and reactors in series, connected to the load terminals.

If air-core reactors are used, a resistor taking approximately 0,6 % of the current through the reactors is connected in parallel with each reactor.

The current shall have substantially sine-wave form and the power factor shall be between 0,85 and 0,9.

For single-pole circuit-breakers and for two-pole circuit-breakers with two protected poles, the metal support is connected to one side of the supply for the first half of the total number of operations and to the other side for the second half.

For two-pole circuit-breakers with one protected pole, the metal support is connected to the neutral of the supply.

Ⓒ *For single-pole circuit-breakers rated 230/400 V the test shall be made at 230 V. Ⓒ*

For three-pole circuit-breakers, the metal support is connected to one phase of the supply for the first half of the total number of operations and to one of the other phases, chosen at random, for the second half.

For four-pole circuit-breakers, the metal support is connected to the neutral of the supply.

The circuit-breaker is connected to the circuit with conductors of the appropriate size indicated in Table 10.

9.11.2 Test procedure

The circuit-breaker is submitted to 4 000 operating cycles with rated current.

Each operating cycle consists of a making operation followed by a breaking operation.

For circuit-breakers of rated current up to and including 32 A the operating frequency shall be 240 operating cycles per hour. During each operating cycle, the circuit-breaker shall remain open for at least 13 s.

For circuit-breakers of rated current above 32 A the operating frequency shall be 120 operating cycles per hour. During each operating cycle the circuit-breaker shall remain open for at least 28 s.

The circuit-breaker shall be operated as in normal conditions of use.

Care shall be taken that

- the test apparatus does not damage the circuit-breaker under test;*
- the free movement of the operating means of the circuit-breaker under test is not impeded;*
- the speed of the operating means of the test apparatus is not unduly affected by the operating means of the circuit-breaker under test.*

In case of circuit-breakers with dependent manual operation, the circuit-breaker shall be operated with an operating speed, during actuation, of $0,1 \text{ m/s} \pm 25 \%$, this speed being measured at the extremity when and where the operating means of the test apparatus touches the actuating means of the circuit-breaker under test. For rotary knobs the angular velocity shall correspond substantially to the above conditions, referred to the speed of the operating means (at its extremities) of the circuit-breaker under test.

9.11.3 Condition of the circuit-breaker after test

Following the test of 9.11.2 the sample shall not show

- undue wear;*
- discrepancy between the position of the moving contacts and of the corresponding position of the indicating device;*
- damage to the enclosure permitting access to live parts by the test finger (see 9.6);*
- loosening of electrical or mechanical connections;*
- seepage of sealing compound.*

☐ Moreover, the circuit-breaker shall comply with the test of 9.10.2.2 and shall withstand the dielectric strength test according to 9.7.3, but at 900 V and without previous humidity treatment. ☐

9.12 Short-circuit tests

9.12.1 General

Standard tests for the verification of the short-circuit performance consist of sequences of making and breaking operations, appropriate to the performance to be checked, which are summarized in Table 16.

The short circuit tests shall be performed at a convenient temperature within the range according to 7.2.

All circuit-breakers are tested at 500 A or $10 I_n$, whichever is the higher, according to 9.12.11.2 and at 1 500 A according to 9.12.11.3.

☐ All multipole circuit-breakers are tested according to 9.12.11.4.4. ☐

Circuit-breakers having a rated short-circuit capacity above 1 500 A are additionally tested

- at service short-circuit (breaking) capacity (see 3.5.5.2) according to 9.12.11.4.2 and 9.12.12.1; the service short-circuit capacity is obtained by multiplying the rated short-circuit capacity by a factor k , the values of which are given in Table 18;
- at rated short-circuit capacity (see 5.2.4) according to 9.12.11.4.3 and to 9.12.12.2 if the factor k is less than 1, in which case new samples shall be used.

Table 16 – Applicability of short-circuit tests

Kind of test	Circuit-breaker to be tested	Verification after short-circuit tests according to subclause
Test at reduced short-circuit currents (9.12.11.2.1)	All circuit-breakers	9.12.12.1
Test to verify suitability for IT systems (9.12.11.2.2)	☐ All circuit-breakers ☐	
Tests at 1 500 A (9.12.11.3)	All circuit-breakers	
Tests at service short-circuit capacity (9.12.11.4.2)	Circuit-breakers with $I_{cn} > 1\,500\text{ A}$	9.12.12.1
Tests at rated short-circuit capacity (9.12.11.4.3)	Circuit-breakers with $I_{cn} > I_{cs}$	9.12.12.2
Tests at the making and breaking capacity on an individual pole (9.12.11.4.4)	Multipole circuit-breakers	9.12.12.2

9.12.2 Values of test quantities

All the tests concerning the verification of the rated short-circuit capacity shall be performed with the values stated by the manufacturer in accordance with the relevant tables of this standard.

The value of the applied voltage is that which is necessary to produce the specified power frequency recovery voltage.

The value of the power frequency recovery voltage (see 3.5.8.2) shall be equal to ☐ 110 % ☐ of the rated voltage of the circuit-breaker under test.

- For single-pole circuit-breakers having dual rated voltage value (e.g. 230/400 V) the power frequency recovery voltage shall be \square 110 % \square of the upper value (e.g. 400 V) for the tests according to item d) of 9.12.11.4.2, item b) of 9.12.11.4.3 and 9.12.11.2.2; it shall be \square 110 % \square of the lower value (e.g. 230 V) for the other tests of 9.12.

\square Text deleted \square

NOTE The value of \square 110 % (0, –5 %) \square of the rated voltage is deemed to cover the effects of the variations of the system voltage under normal service conditions. The upper limit can be increased with the approval of the manufacturer.

9.12.3 Tolerances on test quantities

The tests are considered as valid if the r.m.s. values recorded in the test report differ from the values specified within the following tolerances:

- current $\begin{matrix} +5\% \\ 0 \end{matrix}$
- voltage (including recovery voltage): \square 0, –5 % \square
- frequency $\pm 5\%$.

9.12.4 Test circuit for short-circuit performance

Figure 3 and Figure 4 give the diagrams of the circuits to be used for the tests concerning:

- a single-pole circuit-breaker,
- a two-pole circuit-breaker with one protected pole,
- a two-pole circuit-breaker with two protected poles,
- a three-pole circuit-breaker,
- a four-pole circuit-breaker with three protected poles
- a four-pole circuit-breaker with four protected poles.

The resistances and reactances of the impedances Z and Z1 (see Figure 5) shall be adjustable to satisfy the specified test conditions. The reactors shall preferably be air-cored. They shall always be connected in series with the resistors and their value shall be obtained by series coupling of individual reactors; parallel connecting of reactors is permitted when these reactors have practically the same time-constant.

Since the transient recovery voltage (see 3.5.8.1) characteristics of test circuits including air-cored reactors are not representative of usual service conditions, the air-cored reactor in any phase shall be shunted by a resistor taking approximately 0,6 % of the current through the reactor.

If iron-core reactors are used, the iron-core power losses of these reactors shall not exceed the losses that would be absorbed by the resistors connected in parallel with the air-cored reactors.

There shall be one and only one point of the test circuit which is earthed; this may be the short-circuit link of the test circuit or the neutral point of the supply or any other convenient point. In any case the earthing method shall be stated in the test report.

In each test circuit for testing the rated short-circuit capacity, the impedances Z are inserted between the supply source S and the circuit-breaker under test.

When tests are made with current less than the rated short-circuit breaking capacity, the additional impedances Z₁, shall be inserted on the load side of the circuit-breaker.

For the tests at both the rated and the service short-circuit capacities, the circuit-breaker shall be connected with cables (rigid or flexible) having a length of 0,75 m per pole with the maximum cross-section, corresponding to the rated current, according to the rigid conductor column of Table 5.

A resistor R2 of about 0,5 Ω is connected in series with the frame and further on with copper wire F to point of connection H:

- for testing the single-pole circuit-breaker and two-pole circuit-breaker with one protected pole this connection H is linked to the neutral conductor point D, approximately for half number of operations of the circuit-breaker, and is connected for the remaining operations to the corresponding phase either point C or B.
- for testing either two-pole circuit-breaker with two protected poles, three-pole circuit-breaker, or four-pole circuit-breaker, this connection H is for all operations conducted to D.

The copper wire F shall be at least 50 mm in length and

- *0,1 mm in diameter for circuit-breakers to be tested in free air, mounted on a metal support,*
- *0,3 mm in diameter for circuit-breakers to be tested in the smallest individual enclosure specified by the manufacturer.*

Resistors R_1 drawing a current of 10 A per phase are connected on the supply side of the circuit-breaker, between the impedances for adjusting the prospective current to the rated short-circuit capacity of the circuit-breaker.

9.12.5 Power factor of the test circuit

The power factor of each phase of the test circuit shall be determined according to a recognized method which shall be stated in the test report.

Two examples are given in Annex A.

The power factor of a polyphase circuit is considered as the mean value of the power factors of each phase.

The power-factor ranges are given in Table 17.

Table 17 – Power factor ranges of the test circuit

Test current I_{cc} A	Corresponding power factor range
$I_{cc} \leq 1\,500$	0,93 to 0,98
$1\,500 < I_{cc} \leq 3\,000$	0,85 to 0,90
$3\,000 < I_{cc} \leq 4\,500$	0,75 to 0,80
$4\,500 < I_{cc} \leq 6\,000$	0,65 to 0,70
$6\,000 < I_{cc} \leq 10\,000$	0,45 to 0,50
$10\,000 < I_{cc} \leq 25\,000$	0,20 to 0,25

9.12.6 Measurement and verification of I^2t and of the peak current (I_p)

The I^2t and I_p values shall be measured during the tests of 9.12.11.2, 9.12.11.3 and 9.12.11.4.

In the case of tests of circuit-breakers in three-phase circuits, the I^2t values shall be measured on each pole.

The maximum I^2t values measured shall be recorded in the test report and they shall not exceed the corresponding values of the I^2t characteristic declared by the manufacturer.

9.12.7 Calibration of the test circuit

9.12.7.1 *To calibrate the test circuit, links G1, having negligible impedance compared with that of the test circuit, are connected in the positions shown in Figures 3 and 4.*

9.12.7.2 *To obtain a prospective current equal to the rated short-circuit capacity of the circuit-breaker at the corresponding power factor as stated in Table 16 impedances Z are inserted on the supply side of the links G1.*

9.12.7.3 *To obtain a test current lower than the rated short-circuit capacity of the circuit breaker, additional impedances Z1 are inserted on the load side of the links G1, as shown in figures 3 and 4.*

9.12.8 Interpretation of records

9.12.8.1 Determination of the applied and power frequency recovery voltages

The applied and power frequency recovery voltages are determined from the record corresponding to the opening operation O, (see 9.12.11.1) made with the apparatus under test [C] Text deleted [C]. The voltage on the supply side shall be measured during the first cycle after arc extinction in all poles and after high frequency phenomena have subsided.

9.12.8.2 Determination of the prospective short-circuit current

The a.c. component of the prospective current is taken as being equal to the r.m.s. value of the a.c. component of the calibration current (values corresponding to A2 of Figure 6).

Where applicable, the prospective short-circuit current shall be the average of the prospective currents in all the phases.

9.12.9 Condition of the circuit-breaker for test

9.12.9.1 General

Circuit-breakers shall be tested in free air according to 9.12.9.2, unless they are designed for use only in enclosures specified by the manufacturer or they are intended for use in individual enclosures only, in which cases they shall be tested according to 9.12.9.3 or, with the agreement of the manufacturer, according to 9.12.9.2.

[C] *A circuit-breaker tested according to 9.12.9.2 needs not be tested according to 9.12.9.3. [C]*

NOTE An individual enclosure is an enclosure designed to accept one device only.

The circuit-breaker shall be operated manually or by means of a test apparatus, simulating as closely as possible the normal closing operation.

Care shall be taken that

- *the test apparatus does not damage the circuit-breaker under test;*
- *the free movement of the operating means of the circuit-breaker under test is not impeded;*
- *the speed of the operating means of the test apparatus is not unduly affected by the operating means of the circuit-breaker under test.*

In case of circuit-breakers with dependent manual operation, the circuit-breaker shall be operated with an operating speed, during actuation, of 0,1 m/s \pm 25 %, this speed being measured where and when the operating means of the test apparatus touches the operating means of the circuit-breaker under test. For rotary knobs the angular velocity shall correspond substantially to the above conditions, referred to the speed of the operating means (at its extremities) of the circuit-breaker under test.

9.12.9.2 Test in free air

The circuit-breaker under test is mounted as shown in Figure H.1.

The polyethylene foil and the barrier of insulating material specified in Annex H are placed as shown in Figure H.1 for O operations only.

The grid(s) specified in Annex H shall be so positioned that the bulk of the emitted ionized gases passes through the grid(s). The grid(s) shall be placed in the most unfavourable position(s). If the position of the vents is not obvious, or if there are no vents, appropriate information should be provided by the manufacturer. C In case no information is available, two grids, one above and one below the circuit-breaker, shall be used. C

The grid circuit(s) (see Figure H.3) shall be connected to the points B and C according to the test circuit diagrams of Figures 3 or 4, as applicable; for the test of single-pole circuit-breakers having a rated voltage of 230/400 V the grid circuit(s) shall, however, be connected between phases, to the points B and C' according to the test circuit diagram of Figure 3.

The resistor R' shall have a resistance of 1,5 Ω . The copper wire F' (see Figure H.3) shall have a length of 50 mm and a diameter of 0,12 mm for circuit-breakers having a rated voltage of 230 V and 0,16 mm for circuit-breaker having a rated voltage of 400 V or 230/400 V.

C Text deleted C

For test currents up to and including C 3 000 A C the distance "a" shall be 35 mm.

For higher short-circuit currents up to I_{cn} , the distance "a" may be increased, in which case it shall be chosen from the series (40, 45, 50, 55, etc.) mm and stated by the manufacturer.

For test currents greater than 1 500 A any additional barriers or insulating means which allow a shorter distance "a" shall also be stated by the manufacturer.

9.12.9.3 Test in enclosures

The test shall be performed with the circuit-breaker placed in an enclosure having the most unfavourable configuration under the most unfavourable conditions. The grid and the barrier of insulating material shown in Figure H.1 are omitted.

NOTE This means that if other circuit-breakers (or other devices) are normally mounted in the direction(s) in which the grid(s) would be placed, these circuit-breakers (or other devices) are installed there. They are supplied as in normal use, but via F' and R' as defined in 9.12.9.2, and connected as shown in the appropriate Figure (3 or 4).

In accordance with the manufacturer's instructions, barriers or other means, or adequate clearances may be necessary to prevent ionized gases from affecting the installation.

The polyethylene foil as described in Annex H is placed as shown in Figure H.1 at a distance of 10 mm from the operating means, for O operations only.

9.12.10 Behaviour of the circuit-breaker during short-circuit tests

During the operating sequence of 9.12.11.2 or 9.12.11.3 or 9.12.11.4 the circuit-breaker shall not endanger the operator and shall permit reclosing after the time t as specified in 9.12.11.1, without removing it from the test arrangement.

The polyethylene foil shall show no holes visible with normal or corrected vision without additional magnification.

Furthermore, there shall be no permanent arcing, no flashover between poles or between poles and frame, no melting of the fuse F and, where applicable, of the fuse F' .

9.12.11 Test procedure

9.12.11.1 General

The test procedure consists of a sequence of operations.

The following symbols are used for defining the sequence of operations:

O represents an opening operation;

CO represents a closing operation followed by an automatic opening;

t represents the time interval between two successive short-circuit operations which shall be 3 min or such longer time as may be required by the thermal overcurrent release in order to permit the reclosing of the circuit-breaker. This longer time shall be indicated by the manufacturer.

The actual value of t shall be stated in the test report. If the sample does not allow reclosing after the time indicated by the manufacturer it is considered as having failed the test.

After arc extinction, the recovery voltage shall be maintained for a duration not less than 0,1 s.

9.12.11.2 Tests at reduced short-circuit currents

9.12.11.2.1 Test on all circuit-breakers

The additional impedances Z_1 (see 9.12.7.3) are adjusted so as to obtain a current of 500 A or 10 times I_n , whichever is the higher, at a power factor between 0,93 and 0,98.

Each of the protected poles of the circuit-breaker is subjected separately to a test in a circuit the connections of which are shown in Figure 3.

The circuit-breaker is caused to open automatically nine times, the circuit being closed six times by the auxiliary switch A and three times by the circuit-breaker itself.

The sequence of operations shall be

$$O - t - O - t - O - t - O - t - O - t - O - t - CO - t - CO - t - CO$$

For the test the auxiliary switch A is synchronized with respect to the voltage wave so that the six points of initiation for the opening operations are equally distributed over the half-wave with a tolerance of $\pm 5^\circ$.

9.12.11.2.2 Short-circuit test on circuit-breakers rated 230 V, or 240 V or 230/400 V for verifying their suitability for use in IT systems

The additional impedances Z_1 (see 9.12.7.3) are adjusted so as to obtain a current of 500 A or 1,2 times the upper limit of the standard range of instantaneous tripping given in Table 2, whichever is the higher, but not exceeding 2 500 A, [C] at a power factor between 0,93 and 0,98, at a voltage 105 % of 400 V. [C]

For circuit-breakers having an instantaneous tripping value exceeding $20 I_n$, the impedances are adjusted as to obtain a current 1,2 times the upper limit of instantaneous tripping declared by the manufacturer, the 2 500 A limitation being disregarded.

Single-pole circuit-breakers and each protected pole of multipole circuit-breakers are subjected individually to a test in a circuit the connections of which are shown in Figure 4.

The sequence of operations shall be

O – t – CO

For the O operation on the first protected pole the auxiliary switch T is synchronized with respect to the voltage wave so that the circuit is closed on the point 0° (with a tolerance of ±5°) on the wave for this operation .

For the following O operations on the other protected poles to be tested (see Clause C.2) this point is shifted each time by 30° with respect to the point on wave of the previous test, with a tolerance of ±5°.

9.12.11.3 Test at 1 500 A

For circuit-breakers having a rated short-circuit capacity of 1 500 A, the test circuit is calibrated according to 9.12.7.1 and 9.12.7.2, to obtain a current of 1 500 A at a power factor corresponding to this current according to Table 17.

For circuit-breakers having a rated short-circuit capacity exceeding 1 500 A, the test circuit is calibrated according to 9.12.7.1 and 9.12.7.3, at a power factor corresponding to 1 500 A, according to Table 17.

The circuit breakers are tested in a circuit according to Figure 3.

For three-pole circuit-breakers, no connection G1 is made between the neutral of the supply and the common point, if any, on the load side of the circuit-breaker.

For four-pole circuit-breakers with three protected poles, the neutral of the supply is connected through the unprotected pole or the switched neutral pole to the common point on the load side of the circuit-breaker.

If the neutral of a four-pole circuit-breaker is not marked by the manufacturer, the tests are repeated with three new samples, using successively each pole as neutral in turn.

For the test of single-pole and two-pole circuit-breakers, the auxiliary switch T is synchronized with respect to the voltage wave so that the six points of initiation are equally distributed over the half-wave with a tolerance of ±5°.

The sequence of operations shall be as specified in 9.12.11.2, except for single-pole circuit breakers of rated voltage 230/400 V. In that case only two CO operations are performed following the six O operations; in addition single-pole circuit-breakers are then tested by performing simultaneously one O operation, one circuit-breaker being inserted in each phase of the test circuit specified for three-pole circuit-breakers (Figure 3), without synchronization of the auxiliary switch establishing the short-circuit.

For three-pole and four-pole circuit-breakers, random point-on-wave testing is acceptable.

9.12.11.4 Test above 1 500 A

9.12.11.4.1 Ratio k between service short-circuit capacity and rated short-circuit capacity

The ratio k between the service short-circuit capacity and the rated short-circuit capacity shall be in accordance with Table 18.

Table 18 – Ratio k between service short-circuit capacity (I_{cs}) and rated short-circuit capacity (I_{cn})

I_{cn}	k
$I_{cn} \leq 6\,000\text{ A}$	1
$6\,000\text{ A} < I_{cn} \leq 10\,000\text{ A}$	0,75 ^a
$I_{cn} > 10\,000\text{ A}$	0,5 ^b
^a Minimum value of I_{cs} : 6 000 A	
^b Minimum value of I_{cs} : 7 500 A	

9.12.11.4.2 Test at service short-circuit capacity (I_{cs})

- a) The test circuit is calibrated according to 9.12.7.1 and 9.12.7.3, with a power factor in accordance with Table 17.

Three samples are tested in the relevant circuit specified in 9.12.11.3.

When the supply and load terminals of the circuit-breakers under test are not marked, two of the samples are connected in one direction and the third sample in the reverse direction.

- b) For single-pole and two-pole circuit-breakers the sequence of operation is:

O – t – O – t – CO

For the O operations, the auxiliary switch A is synchronized with respect to the voltage wave so that the circuit is closed on the point 0° on the wave for the O operation on the first sample.

This point is then shifted by 45° for the second O operation on the first sample; for the second sample, the two O operations shall be synchronized at 15° and 60° and for the third sample at 30° and 75°.

The synchronization tolerance shall be ±5°.

For two-pole circuit-breakers, the same pole shall be used as reference for the purpose of synchronization.

This test procedure is shown in Table 19.

Table 19 – Test procedure for I_{cs} in the case of single- and two-pole circuit-breakers

Operation	Sample		
	1	2	3
1	O (0°)	O (15°)	O (30°)
2	O (45°)	O (60°)	O (75°)
3	CO	CO	CO

- c) For three-pole and four-pole circuit-breakers the sequence of operations is:

O – t – CO – t – CO

For the O operations, the auxiliary switch A is synchronized with respect to the voltage wave so that the circuit is closed on any point (x°) on the wave for the O operation on the first sample.

This point is then shifted by 60° for the O operation on the second sample and by a further 60° for the O operation on the third sample.

The synchronization tolerance shall be ±5°. The same pole shall be used as reference for the purpose of synchronization for the different samples.

This test procedure is shown in Table 20.

Table 20 – Test procedure for I_{cs} in the case of three- and four-pole circuit-breakers

Operation	Sample		
	1	2	3
1	O (x°)	O ($x^\circ+60^\circ$)	O ($x^\circ+120^\circ$)
2	CO	CO	CO
3	CO	CO	CO

d) For single-pole circuit-breakers of rated voltage 230/400 V an additional set of three samples is tested in a circuit according to Figure 3 without N- connection .

These samples are inserted one in each phase of the test circuit, without synchronization of the auxiliary switch A establishing the short-circuit.

No connection shall be made between the neutral of the supply and the common point on the load side of the circuit-breakers.

The test procedure is shown in Table 21.

During this test the I^2t values need not be measured.

Table 21 – Test procedure for I_{cs} in the case of three-phase tests for single-pole circuit-breakers of rated voltage 230/400 V

Operation	Sample		
	1	2	3
1	O	O	O
2	–	CO	O
3	O	–	CO
4	CO	O	–

9.12.11.4.3 Test at rated short-circuit capacity (I_{cn})

a) The test circuit is calibrated according to 9.12.7.1 and 9.12.7.2.

Three samples are tested in the relevant circuit specified in 9.12.11.3.

When the supply and load terminals of the circuit-breakers under test are not marked, two of the samples are connected in one direction and the third sample in the reverse direction.

The sequence of operations is

$$O - t - CO$$

For the O operations, the auxiliary switch A is synchronized with respect to the voltage wave so that the circuit is closed on the point 15° on the wave for the O operation on the first sample.

This point is then shifted by 30° for the O operation of the second sample and by further 30° for the O operation of the third sample.

The synchronization tolerance shall be $\pm 5^\circ$.

For multipole circuit-breakers the same pole shall be used as reference for the purpose of synchronization.

The test procedure is shown in Table 22.

Table 22 – The test procedure for I_{cn}

Operation	Sample		
	1	2	3
1	O (15°)	O (45°)	O (75°)
2	CO	CO	CO

b) For single-pole circuit-breakers of rated voltage 230/400 V an additional set of four samples is tested in a circuit according to Figure 3 without N-connection .

Three of these samples are inserted one in each phase of the test circuit, without synchronization of the auxiliary switch A establishing the short-circuit.

No connection shall be made between the neutral of the supply and the common point on the load side of the circuit-breakers.

The test procedure is shown in Table 23.

After the second O operation of the sample shown as number 1 in Table 23 this sample shall be replaced by the fourth sample.

During this test the I^2t values need not be measured.

Table 23 – Test procedure for I_{cn} in the case of three-phase tests for single-pole circuit-breakers of rated voltage 230/400 V

Operation	Sample			
	1	2	3	4
1	O	O	O	–
2	O	CO	–	–
3	–	–	CO	O

9.12.11.4.4 Test at the making and breaking capacity on an individual pole (I_{cn1}) of multipole circuit-breakers

The test circuit is calibrated according to 9.12.7.

The test is carried out on one pole taken at random which shall not be the switched neutral.

This pole is connected according to the diagram of Figure 3, but with the neutral of the supply being connected directly downstream impedance Z1, so as to apply phase to neutral voltage to the tested pole.

In addition phases which do not carry the short-circuit current during this test shall be connected to their supply voltage at the corresponding terminals.

The sequence of operation is:

O – t – CO

For the " O " operations, the auxiliary switch T is synchronized with respect to the voltage wave so that the circuit is closed on the point 15° on the wave for the " O " operation on the first sample.

This point is then shifted by 30° for the " O " operation on the second sample and by a further 30° for the " O " operation on the third sample.

The synchronization tolerance shall be $\pm 5^\circ$.

For the three- and four-pole circuit-breakers, the same pole shall be used as reference for the purpose of synchronization

9.12.12 Verification of the circuit breaker after short circuit tests.:

9.12.12.1 Verifications after the tests at reduced short-circuit currents, at 1 500 A and at service short-circuit capacity

After the tests according to 9.12.11.2, 9.12.11.3 or 9.12.11.4.2, the circuit-breakers shall show no damage impairing their further use and shall, without maintenance, withstand the following tests.

- a) *Leakage current across open contacts, according to 9.7.5.3.*
- b) *Dielectric strength tests according to 9.7.3, carried out between 2 h and 24 h after the short-circuit tests at a voltage of 500 V less than the value prescribed in 9.7.5 and without previous humidity treatment.*

After the test carried out under the conditions specified in item a) of 9.7.2, it shall be verified that the indicating means show the open position.

During the test carried out under the conditions specified in item b) of 9.7.2 the indicating means shall show the closed position.

- c) *Moreover, after the test of 9.12.11.3 or 9.12.11.4.2, the circuit-breakers shall not trip when a current equal to 0,85 times the conventional non-tripping current is passed through all poles for the conventional time, starting from cold.*

At the end of this verification the current is steadily increased, within 5 s, to 1,1 times the conventional tripping current.

The circuit-breakers shall trip within the conventional time.

9.12.12.2 Verifications after the short-circuit test at rated short-circuit capacity

After the tests according to 9.12.11.4.3 and 9.12.11.4.4 the polyethylene foil shall show no holes visible with normal or corrected vision without additional magnification and the circuit-breakers shall show no damage impairing their further use and shall, without maintenance, withstand the following tests:

- a) *Leakage current across open contacts, according to 9.7.5.3.*
- b) *Dielectric strength tests according to 9.7.3, carried out between 2 h and 24 h after the short-circuit tests at a voltage of 900 V and without previous humidity treatment.*

After the test carried out under the conditions specified in item a) of 9.7.2, it shall be verified that the indicating means show the open position.

During the test carried out under the conditions specified in item b) of 9.7.2 the indicating means shall show the closed position.

- c) *Moreover the circuit-breakers shall trip within the time corresponding to the test c of Table 7 when a current equal to 2,8 I_n is passed through all poles, the lower time limit being 0,1 s instead of 1 s.*

The sample shown as number 1 in Table 23 is not subjected to the verification of this subclause, but it shall nevertheless comply with the requirements of 9.12.10.

9.13 Mechanical stresses

9.13.1 Mechanical shock

NOTE The mechanical shock test is intended to test the latching means of the circuit-breaker, not its mounting means. **NOTE**

9.13.1.1 Test device

The circuit-breaker is subjected to mechanical shocks using an apparatus as shown in Figure 7.

A wooden base A is fixed to a concrete block and a wooden platform B is hinged to base A. This platform carries a wooden board C, which can be fixed at various distances from the hinge and in two vertical positions.

The end of board B bears a metal stop-plate D which rests on a coiled spring having a constant c of 25 N/mm.

The circuit-breaker is secured to the vertical board in such a way that the distance of the horizontal axis of the sample is 180 mm from the platform, the vertical board being in turn so fixed that the distance of the mounting surface is 200 mm from the hinge, as shown in the Figure 7.

On the surface C, opposite the mounting surface of the circuit-breaker, a supplementary mass is fixed so that the static force on the metal stop-plate is 25 N in order to ensure that the moment of inertia of the complete system is substantially constant.

9.13.1.2 Test procedure

With the circuit-breaker in the closed position, but not connected to any electrical source, the platform is lifted at its free end and then allowed to fall 50 times from a height of 40 mm, the interval between consecutive falls being such that the sample is allowed to come to rest.

The circuit-breaker is then secured to the opposite side of the vertical board C and the platform is allowed to fall 50 times as before.

After this test, the vertical board is turned through 90° about its vertical axis and, if necessary, repositioned so that the vertical axis of symmetry of the circuit-breaker is 200 mm from the hinge.

The platform is then allowed to fall 50 times as before, with the circuit-breaker on one side of the vertical board, and 50 times with the circuit-breaker on the opposite side.

Before each change of position, the circuit-breaker is manually opened and closed.

During the tests, the circuit-breaker shall not open.

9.13.2 Resistance to mechanical stresses and impact

9.13.2.1 *Compliance is checked on those exposed parts of the circuit-breaker mounted as for normal use (see note in 8.1.6), which may be subjected to mechanical impact in normal use, by the test of 9.13.2.2 for all types of circuit-breakers and, in addition, by the tests specified in:*

- 9.13.2.3 for screw-in type circuit-breakers;
- 9.13.2.4 for circuit-breakers intended to be mounted on a rail and for all types of plug-in circuit-breakers designed for surface mounting;
- 9.13.2.5 for plug-in type circuit-breakers, the holding in position of which depends solely on their connections.

Circuit-breakers only intended to be totally enclosed are not submitted to this test.

9.13.2.2 *The samples are subjected to blows by means of an impact-test apparatus as shown in Figure 9 to Figure 13.*

The head of the striking element has a hemispherical face of radius 10 mm and is of polyamide having a Rockwell hardness of HR 100.

The striking element has a mass of (150 ± 1) g and is rigidly fixed to the lower end of a steel tube with an external diameter of 9 mm and a wall thickness of 0,5 mm, which is pivoted at its upper end in such a way that it swings only in a vertical plane.

The axis of the pivot is $(1\ 000 \pm 1)$ mm above the axis of the striking element.

For determining the Rockwell hardness of the polyamide of the head of the striking element, the following conditions apply:

- *diameter of the ball: $(12,7 \pm 0,0025)$ mm,*
- *initial load: (100 ± 2) N;*
- *overload: $(500 \pm 2,5)$ N.*

NOTE 1 Additional information concerning the determination of the Rockwell hardness of plastics is given in ISO 2039-2.

The design of the test apparatus is such that a force of between 1,9 N and 2,0 N has to be applied to the face of the striking element to maintain the tube in the horizontal position.

Surface-type circuit-breakers are mounted on a sheet of plywood, 8 mm thick and 175 mm square, secured at its top and bottom edges to a rigid bracket, which is part of the mounting support, as shown in Figure 11.

The mounting support shall have a mass of (10 ± 1) kg and shall be mounted on a rigid frame by means of pivots.

The frame is fixed to a solid wall.

Flush-type circuit-breakers are mounted in a device as shown in Figure 12, which in turn is fixed to the mounting support shown in Figure 11.

Panel board type circuit-breakers are mounted in a device as shown in Figure 13, which in turn is fixed to the mounting support shown in Figure 11.

Plug-in type circuit-breakers are mounted complete with the appropriate means for the plug-in connection, which means are fixed on the sheet of plywood for the surface-type, or in the device according to Figure 12 for the flush-type or Figure 13 for the panel-board-type, as applicable.

Screw-in type circuit-breakers are mounted in their appropriate base which is fixed to a mounting square plate made of a plywood sheet, 8 mm thick and 175 mm sides.

Circuit-breakers for screw fixing are fixed by means of screws.

Circuit-breakers for rail mounting are mounted on their appropriate rail.

Circuit-breakers intended both for screw fixing and for rail mounting shall be fixed with screws for the tests.

The design of the test apparatus is such that

- *the sample can be moved horizontally and turned about an axis perpendicular to the surface of the plywood;*
- *the plywood can be turned about a vertical axis.*

The circuit-breaker is mounted on the plywood or on the appropriate device as for normal use, with covers, if any, so that the point of impact lies in the vertical plane through the axis of the pivot of the pendulum.

Cable entries which are not provided with knock-outs are left open. If they are provided with knock-outs, two of them are opened.

Before applying the blows, fixing screws of bases, covers and the like are tightened with a torque equal to two-thirds of that specified in Table 11.

The striking element is allowed to fall from a height of 10 cm onto surfaces which are exposed when the circuit-breaker is mounted as for normal use.

The height of fall is the vertical distance between the position of a checking point when the pendulum is released and the position of that point at the moment of impact.

The checking point is marked on the surface of the striking element where the line through the point of intersection of the axis of the steel tube of the pendulum and that of the striking element, and perpendicular to the plane through both axes, meets the surface.

NOTE 2 Theoretically, the centre of gravity of the striking element is the checking point. As the centre of gravity is difficult to determine, the checking point is chosen as specified above.

Each circuit-breaker is subjected to ten blows, two of them being applied to the operating means and the remainder being evenly distributed over the parts of the sample likely to be subjected to impacts.

The blows are not applied to knock-out areas or to any openings covered by transparent material.

In general, one blow is applied on each lateral side of the sample after it has been turned as far as possible, but not through more than 60°, about a vertical axis, and two blows are applied, each approximately midway between the blows on a lateral side and the blows on the operating means.

The remaining blows are then applied in the same way, after the sample has been turned through 90° about that of its axes which is perpendicular to the plywood.

If cable entries or knock-outs are provided, the sample is so mounted that the two lines of blows are as nearly as possible equidistant from these entries.

Two blows shall be applied on the operating means as follows: one when the operating means is in the closed position and the other when it is in the open position.

After the test the samples shall show no damage within the meaning of this standard. In particular covers which, when broken, make live parts accessible or impair the further use of the circuit-breaker, operating means, linings and barriers of insulating material and the like, shall not show such damage.

In case of doubt, it shall be verified that removal and replacement of external parts, such as enclosures and covers, is possible without these parts or their lining being damaged.

NOTE 3 Damage to the appearance, small dents which do not reduce the creepage distances or clearances below the values specified in 8.1.3 and small chips which do not adversely affect the protection against electric shock are neglected.

9.13.2.3 *Screw-in type circuit-breakers are screwed home in an appropriate base, a torque of 2,5 Nm being applied for 1 min.*

After the test the sample shall show no damage impairing its further use.

9.13.2.4 *Circuit-breakers designed to be mounted on a rail are mounted as for normal use, but without cables being connected and without any cover or coverplate, on a rail rigidly fixed on a vertical rigid wall.*

Plug-in circuit-breakers designed for surface mounting are mounted complete with the appropriate means for the plug-in connection but without cables being connected and without any cover-plate.

A downward vertical force of 50 N is applied without jerks for 1 min on the forward surface of the circuit-breaker, immediately followed by an upward vertical force of 50 N for 1 min (see Figure 14).

During this test, the circuit-breaker shall not become loose and after the test the circuit-breaker shall show no damage impairing its further use.

9.13.2.5 *Plug-in type circuit-breakers, the holding in position of which depends solely on their connections, are mounted, complete with the appropriate plug-in base but without cables being connected and without any cover-plate, on a vertical rigid wall.*

A force of 20 N is applied to the circuit-breaker portion at a point equidistant between the plug-in connections, without jerks for 1 min (see Figure 16).

During this test the circuit-breaker portion shall not become loose and shall not move from the base portion and after the test both portions shall show no damage impairing their further use.

9.14 Test of resistance to heat

9.14.1 *The samples, without removable covers, if any, are kept for 1 h in a heating cabinet at a temperature of (100 ± 2) °C; removable covers, if any, are kept for 1 h in the heating cabinet at a temperature of (70 ± 2) °C.*

During the test the samples shall not undergo any change impairing their further use and sealing compound, if any, shall not flow to such an extent that live parts are exposed.

After the test and after the samples have been allowed to cool down to approximately room temperature, there shall be no access to live parts which are normally not accessible when the samples are mounted as for normal use, even if the standard test finger is applied with a force not exceeding 5 N.

After the test, markings shall still be legible.

Discoloration, blisters or a slight displacement of the sealing compound are disregarded, provided that safety is not impaired within the meaning of this standard.

9.14.2 *External circuit-breaker parts made of insulating material necessary to retain in position current-carrying parts and parts of the protective circuit are subjected to a ball-pressure test by means of the apparatus shown in Figure 15 except that, where applicable, the insulating parts necessary to retain in position the terminals for protective conductors in a box shall be tested as specified in 9.14.3.*

The part to be tested is placed on a steel support with the appropriate surface in the horizontal position and a steel ball of 5 mm diameter is pressed against this surface with a force of 20 N.

The test is made in a heating cabinet at a temperature of (125 ± 2) °C.

After 1 h, the ball is removed from the sample which is then cooled down within 10 s to approximately room temperature by immersion in cold water.

The diameter of the impression caused by the ball is measured and shall not exceed 2 mm.

9.14.3 *External circuit-breaker parts made of insulating material not necessary to retain in position current-carrying parts and parts of the protective circuit, even though they are in contact with them, are subjected to a ball-pressure test in accordance with 9.14.2, but the test is made at a temperature of (70 ± 2) °C, or (40 ± 2) °C plus the highest temperature rise, determined for the relevant part during the test of 9.8, whichever is the higher.*

NOTE 1  Void 

NOTE 2 The tests of 9.14.2 and 9.14.3 are not made on parts of ceramic material.

NOTE 3 If two or more of the insulating parts referred to in 9.14.2 and 9.14.3 are made of the same material, the test according to 9.14.2 or 9.14.3, as applicable, is carried out on only one of these parts.

9.15 Resistance to abnormal heat and to fire

The glow-wire test is performed on a complete circuit breaker in accordance with IEC 60695-2-10 under the following conditions:

- *for external parts of circuit-breakers made of insulating material necessary to retain in position current-carrying parts and parts of the protective circuit, by the test made at a temperature of (960 ± 15) °C;*
- *for all other external parts made of insulating material, by the test made at a temperature of (650 ± 10) °C.*

 Text deleted 

Small parts, where each surface lies completely within a circle of 15 mm diameter, or where any part of the surface lies outside a 15 mm diameter circle and it is not possible to fit a circle of 8 mm diameter on any of the surfaces, are not subjected to the test of this subclause (see Figure 17 for diagrammatic representation).

If a number of insulating parts is made of the same material, the test is carried out only on one of these parts, according to the appropriate glow-wire test temperature.

The test is not made on parts of ceramic material.

The glow-wire test is applied to ensure that an electrically heated test wire under defined test conditions does not cause ignition of insulating parts, or to ensure that a part of insulating material, which might be ignited by the heated test wire under defined conditions, has a limited time to burn without spreading fire by flame or burning parts or droplets falling down from the tested part. The test is made on three samples, points of application of glow wire test being different from one sample to another one.

The glow wire cannot be applied directly to terminals area or arc chamber or magnetic tripping device area, where the glow-wire cannot protrude far through the outer surface before touching either relatively big metal parts or even ceramics, which will cool down the glow-wire quickly and in addition limit the amount of insulating material ever getting in touch with the glow-wire. In this situation the parts ensure minimum severity of the test by cooling down the glow-wire and limiting access to the insulating material under test.

The sample shall be positioned during the test in the most unfavourable position of its intended use (with the surface tested in a vertical position).

If an internal part of insulation material influences the test with negative result, it is allowed to remove the relevant identified internal part(s) of insulation material from a new sample. Then, the glow wire test shall be repeated at the same place on this new sample.

In accordance with the manufacturer, it is acceptable as an alternative method to remove the part under examination in its entirety and test it separately (see IEC 60695-2-11:2000, Clause 4).

The sample is regarded as having passed the glow-wire test if

- *either there is no visible flame and no sustained glowing,*
- *or flames and glowing on the sample extinguish themselves within 30 s after the removal of the glow-wire.*

There shall be no ignition of the tissue paper or scorching of the pinewood board.

9.16 Test of resistance to rusting

All grease is removed from the parts to be tested by immersion in a cold chemical degreaser such as methyl-chloroform or refined petrol, for 10 min. The parts are then immersed for 10 min in a 10 % solution of ammonium chloride in water at a temperature of $(20 \pm 5) ^\circ\text{C}$.

Without drying, but after shaking off any drops, the parts are placed for 10 min in a box containing air saturated with moisture at a temperature of $(20 \pm 5) ^\circ\text{C}$.

After the parts have been dried for 10 min in a heating cabinet at a temperature of $(100 \pm 5) ^\circ\text{C}$, their surfaces shall show no signs of rust.

NOTE Traces of rust on sharp edges and any yellowish film removable by rubbing are ignored.

For small springs and the like and for inaccessible parts exposed to abrasion, a layer of grease may provide sufficient protection against rusting. Such parts are only subjected to the test if there is a doubt as to the effectiveness of the grease film, and in such a case the test is made without previous removal of the grease.

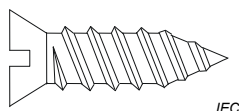

Figure 1 – Thread forming tapping screw (3.3.22)

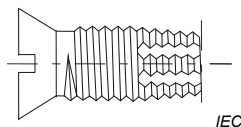
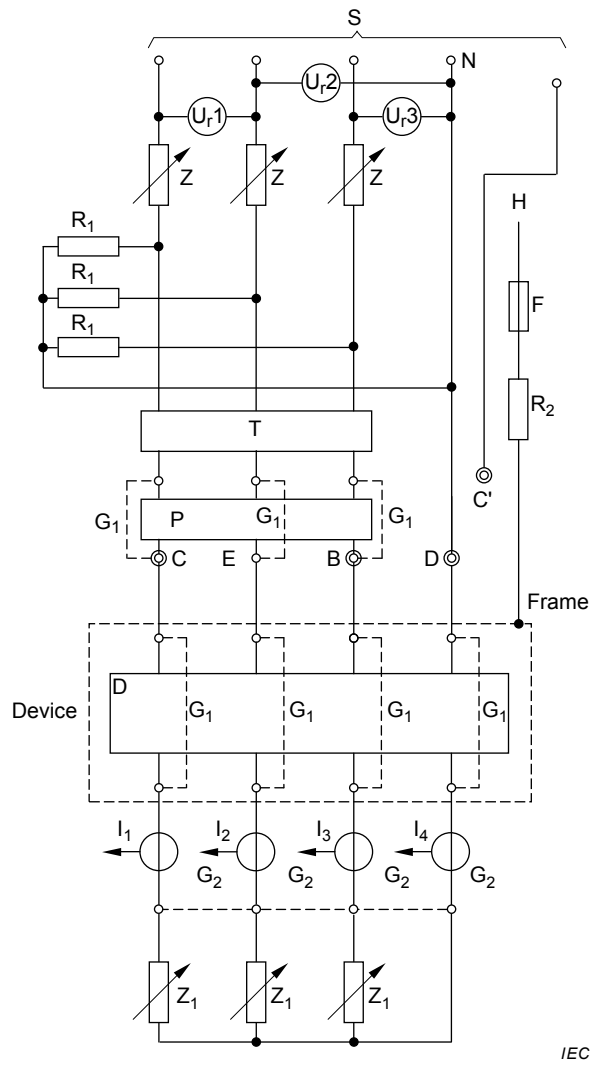
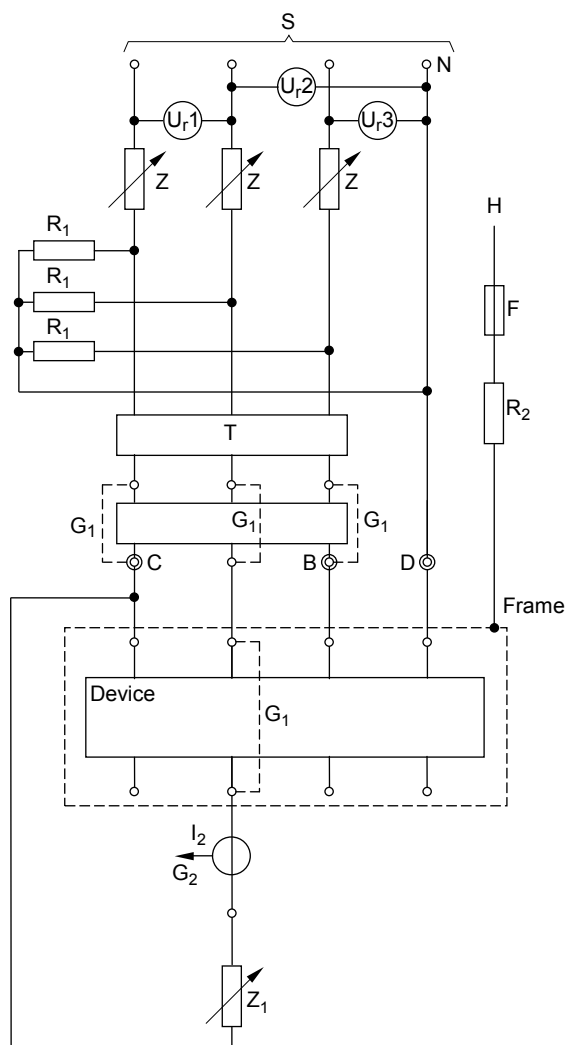

Figure 2 – Thread cutting tapping screw (3.3.23)



IEC

Figure 3 – Typical diagram for all short circuit tests except for 9.12.11.2.2)



IEC

Figure 4 – Typical diagram for short circuit tests according to 9.12.11.2.2)

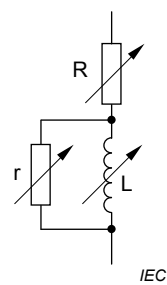

IEC

Figure 5 – Detail of impedance Z and Z₁

Explanation of letter symbols used in Figures 3, 4 and 5

N	=	Neutral conductor
S	=	Supply
R	=	Adjustable resistor(s)
Z	=	Impedance in each phase for the calibration of the rated short-circuit current. The reactors shall preferably be air-cored and connected in series with resistors in order to obtain the required power factor.
Z ₁	=	Adjustable impedance to obtain current below the rated short-circuit current
frame	=	All conductive parts normally earthed in service, including FE, if any
G ₁	=	Temporary connection(s) for calibration
G ₂	=	Connection(s) for the test with rated short-circuit current
T	=	Making switch for the short-circuit
I ₁ , I ₂ , I ₃ , I ₄	=	Current sensor(s) May be situated on the supply or on the load side of device under test, but always on the secondary side of the transformer
Ur ₁ , Ur ₂ , Ur ₃	=	Voltage sensor(s)
F	=	Copper wire for the detection of a fault current
R ₁	=	Resistance drawing a current of approximately 10 A per phase
R ₂	=	Resistor limiting the current in the device F
r	=	Resistor(s) taking approximately 0,6 % of the current
B, C and C'	=	Points for the connections of the grid(s) shown in Annex C
L	=	Adjustable air cored inductance(s)
P	=	Short circuit protective device for test according to Annex D

NOTE 1 The closing device T can alternatively be situated between the load side terminals of the device under test and current sensors I₁, I₂ and I₃ as applicable.

NOTE 2 The voltage sensors Ur₁, Ur₂ and Ur₃ are connected between phase and neutral, as necessary.

NOTE 3 The adjustable load Z can be located at the high-voltage side of the supply circuit.

NOTE 4 Resistances R₁ can be omitted with the agreement of the manufacturer.

NOTE 5 0,5 m are connected on the supply side and 0,25 m on the load side of the circuit-breaker under test.

C

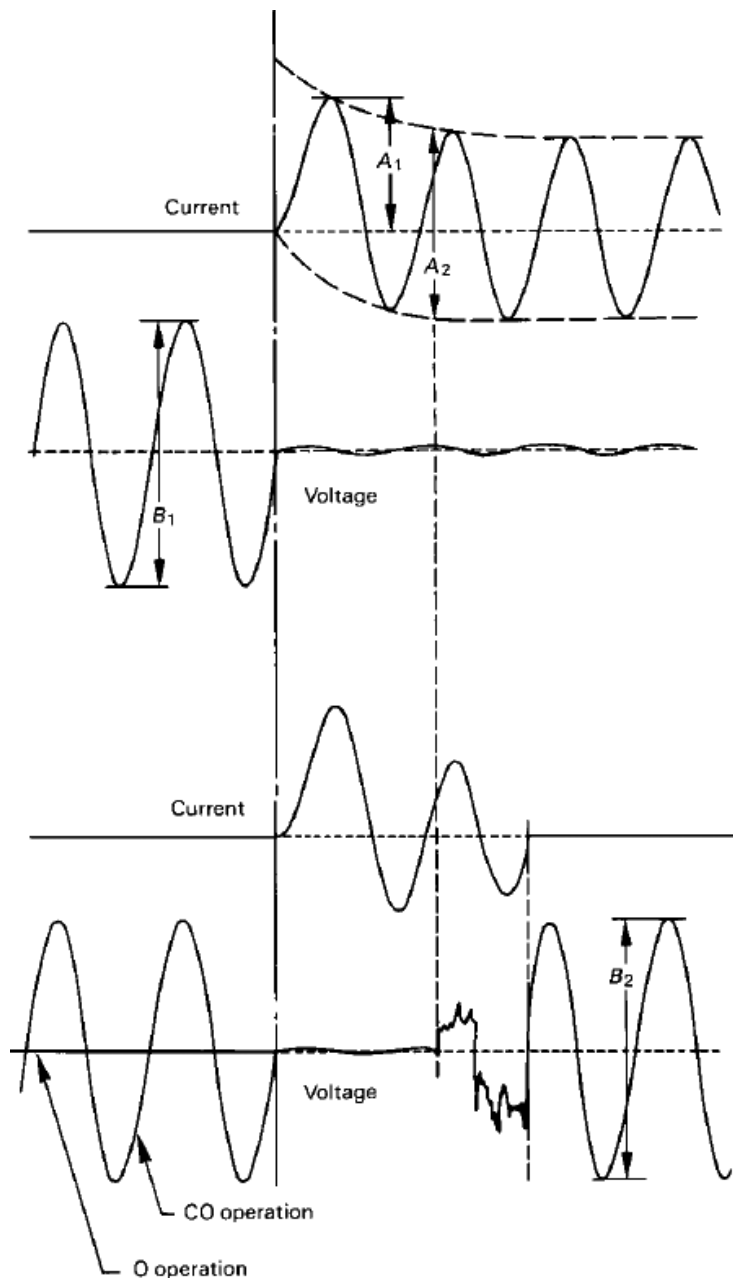

a) = Calibration of circuit

 A_1 = Prospective peak making current $\frac{A_2}{2\sqrt{2}}$ = Prospective symmetrical breaking current (r.m.s. value) $\frac{B_1}{2\sqrt{2}}$ = Applied voltage (r.m.s. value) (see 3.5.7)

b) = O or CO operation

 $\frac{A_2}{2\sqrt{2}}$ = Breaking capacity (r.m.s. value) A_1 = Making capacity (peak value) $\frac{B_2}{2\sqrt{2}}$ = Recovery voltage (r.m.s. value) (see 3.5.8)

IEC 1444/2000

Figure 6 — Calibration of the test circuit

C

Dimensions in millimetres

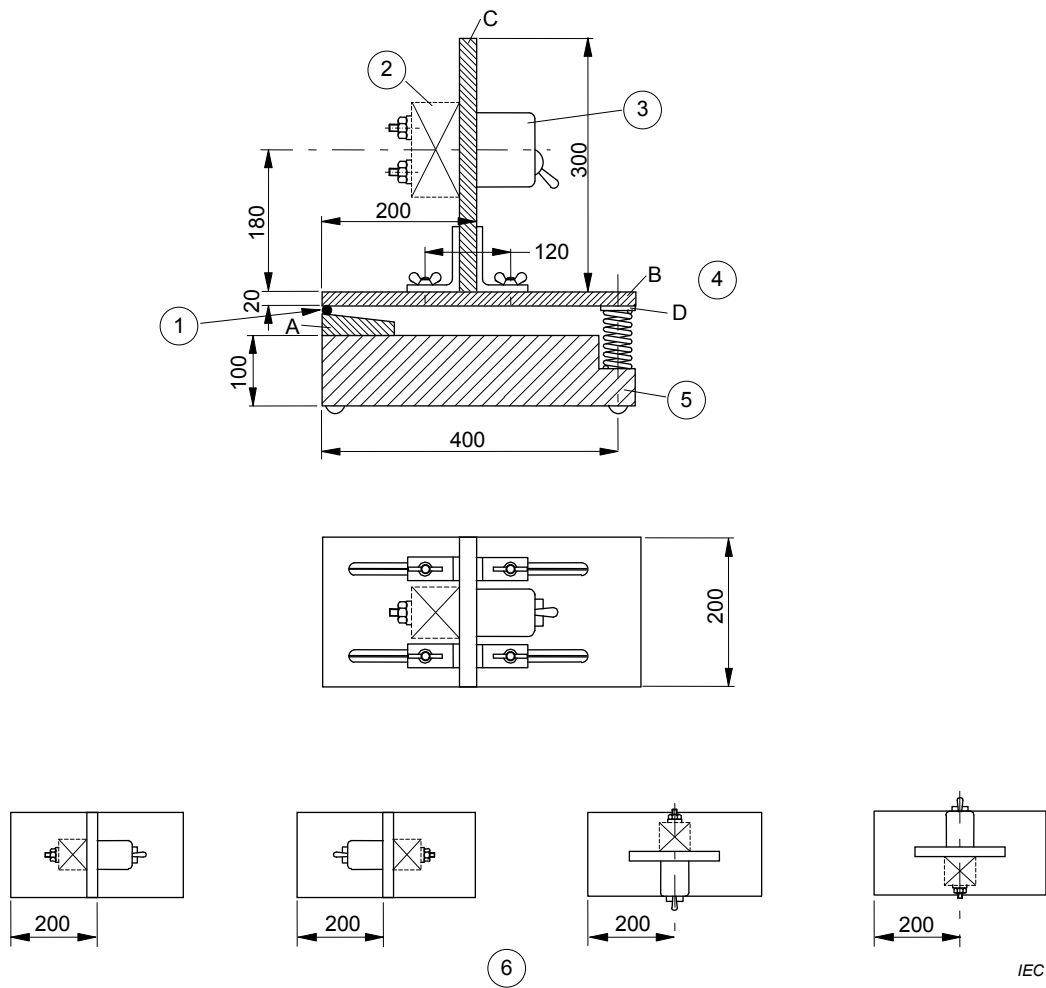

Key

- 1 Hinge
- 2 Additional mass
- 3 Sample
- 4 Metal stop plate
- 5 Concrete block
- 6 Consecutive test positions

Figure 7 – Mechanical shock test apparatus (9.13.1)

Dimensions in millimetres

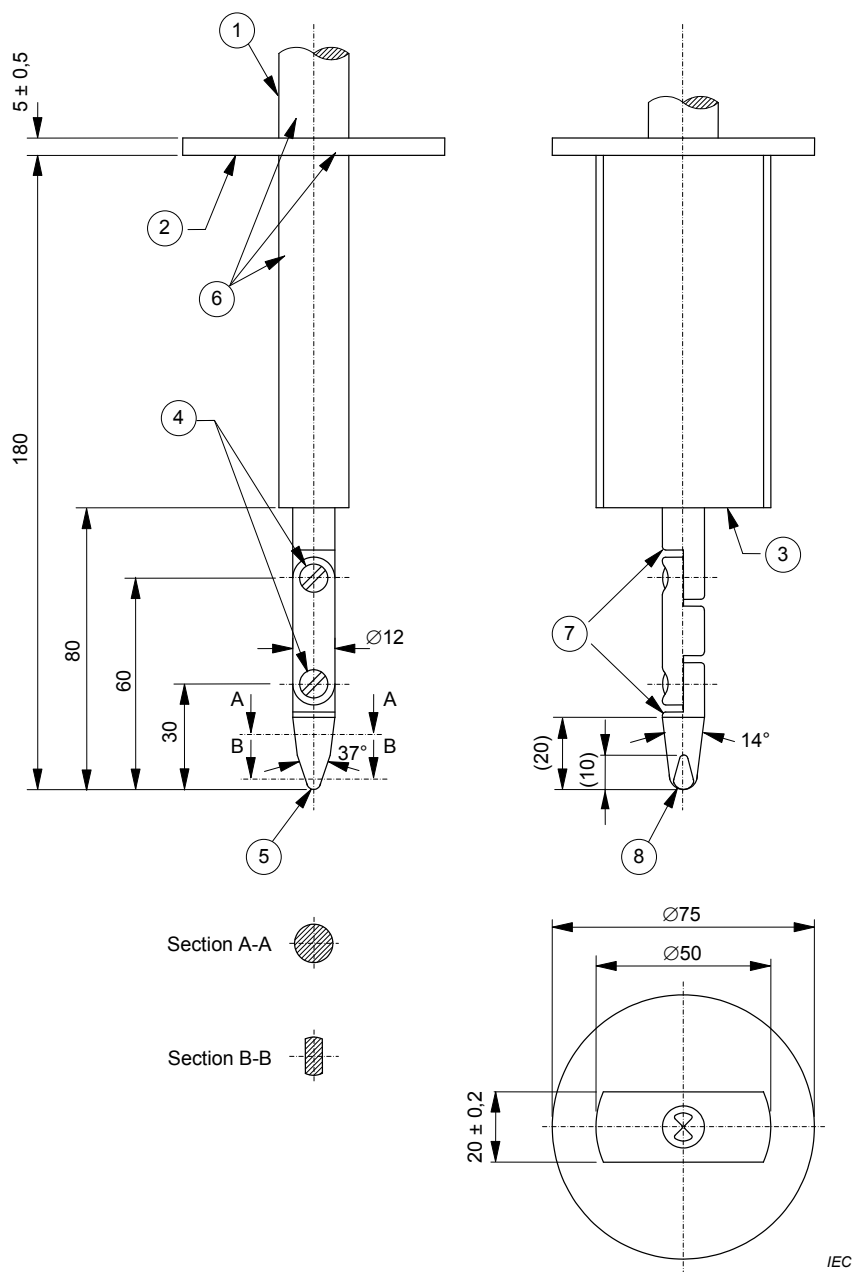
**Key**

1 Handle

2 Guard

3 Stop face

4 Joints

Material : metal, except where otherwise specified
Tolerances on dimensions without specific tolerance:on angles: $\begin{matrix} 0 \\ -10 \end{matrix}$ on linear dimensions:
up to 25 mm: $\begin{matrix} 0 \\ -0,05 \end{matrix}$ over 25 mm: $\pm 0,2$ 5 $R2 \pm 0,05$ cylindrical

6 Insulating material

7 Chamfer all edges

8 $R4 \pm 0,05$ sphericalBoth joints shall permit movement in the same plane and the same direction through an angle of 90° with a tolerance of $+10^\circ$.

0

Figure 8 – Standard test finger (9.6)

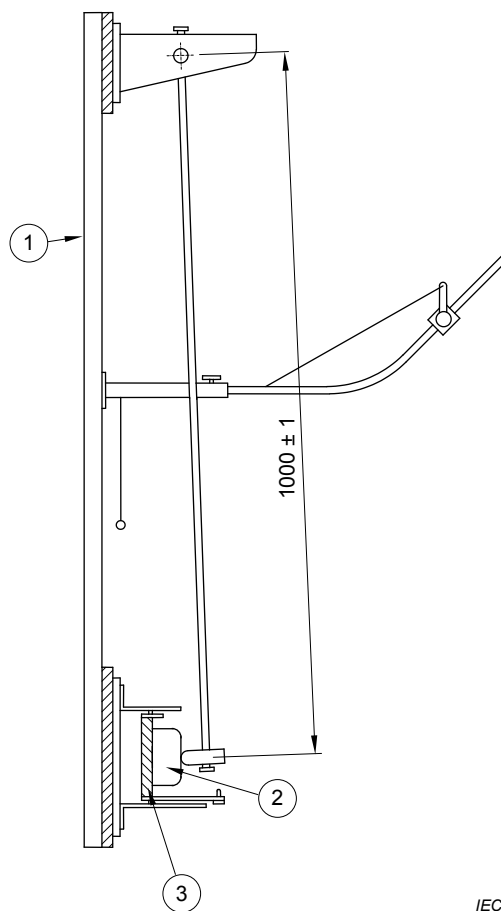
Dimensions in millimetres

IEC

Key

- 1 Frame
- 2 Sample
- 3 Mounting support

Figure 9 – Mechanical impact test apparatus (9.13.2)

Dimensions in millimetres

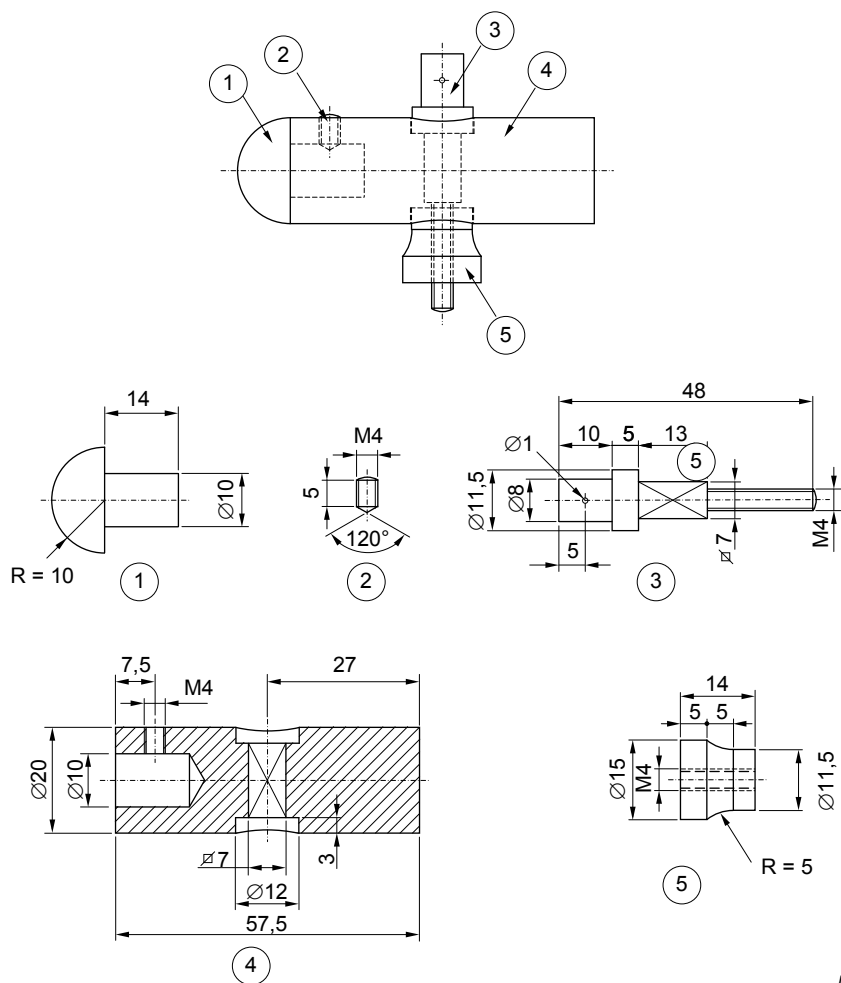

IEC

Key

- 1 Polyamide
2, 3, 4, 5 Steel Fe 360

**Figure 10 – Striking element for pendulum
for mechanical impact test apparatus (9.13.2)**

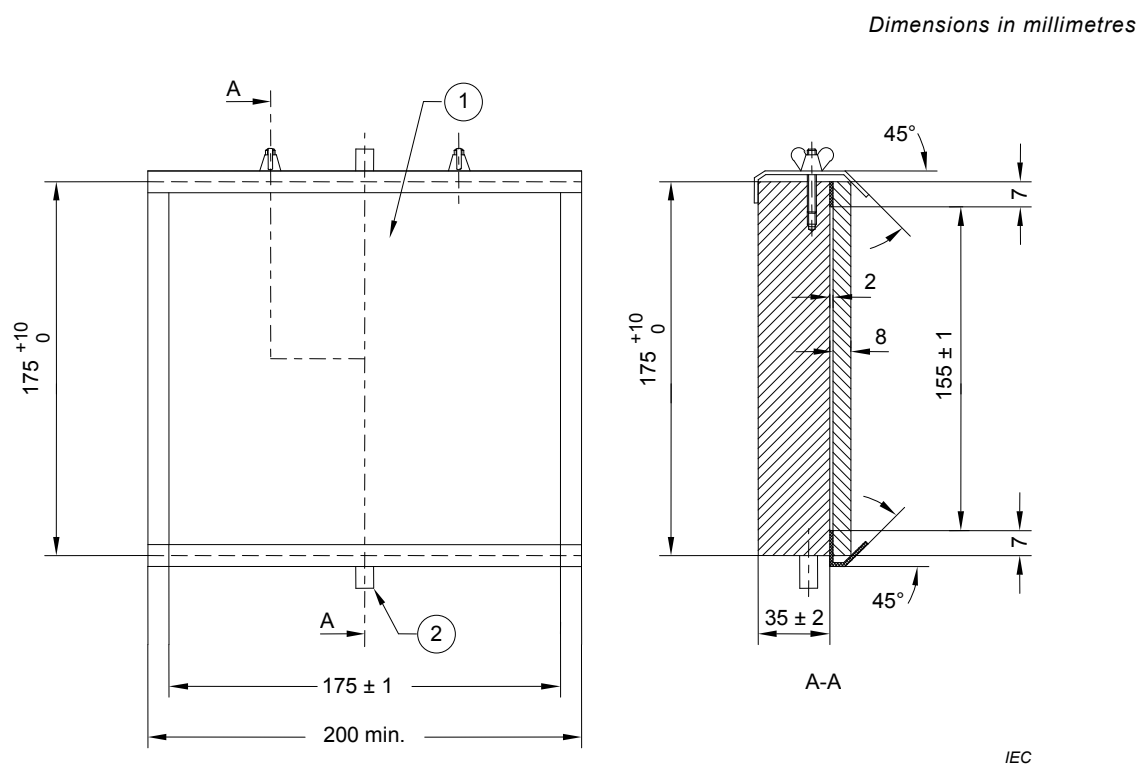
**Key**

- 1 Sheet of plywood
- 2 Pivot

Figure 11 – Mounting support for mechanical impact test (9.13.2)

Dimensions in millimetres

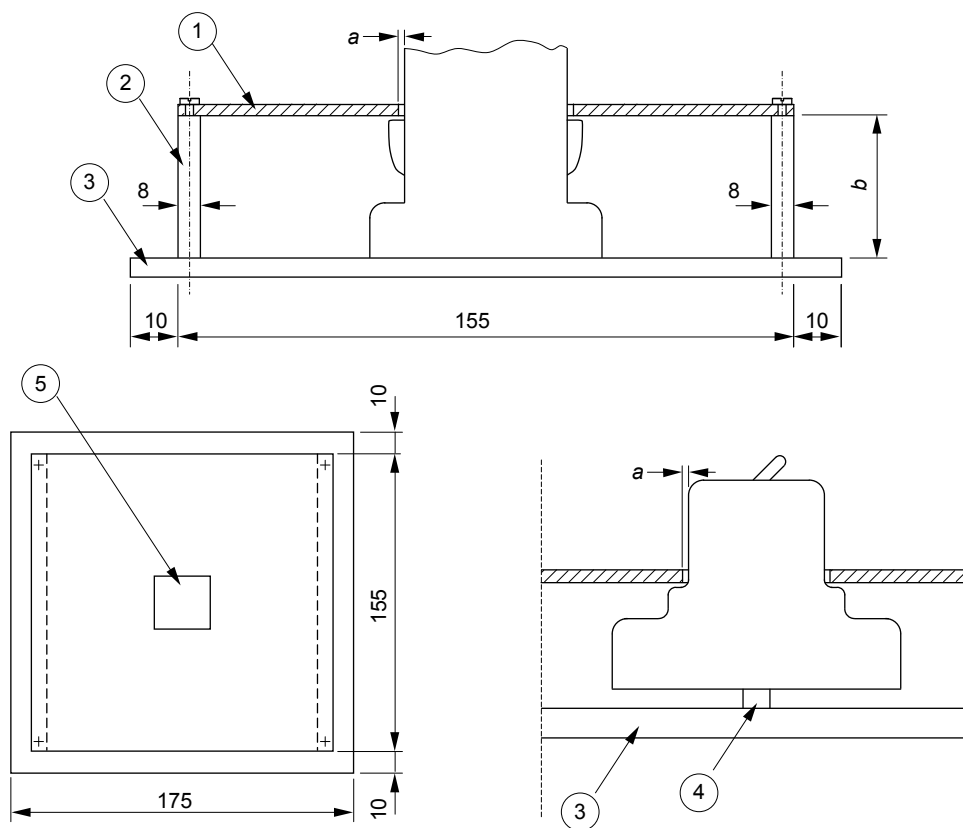

IEC

Key

- 1 Interchangeable steel plate with a thickness of 1 mm
 - 2 Aluminium plates with a thickness of 8 mm
 - 3 Mounting plate
 - 4 Rail for circuit-breakers designed for rail mounting
 - 5 Cut-out for the circuit-breaker in the steel plate
- a* the distance between the edges of the cut-out and the faces of the circuit-breaker shall be between 1 mm and 2 mm
- b* the height of the aluminium plates shall be such that the steel plate rests on the supports of the circuit-breaker or, if the circuit-breaker has no such support, the distance from live parts, which are to be protected by an additional cover plate, to be on the underside of the steel, is 8 mm.

Figure 12 – [C] Examples of mounting of a flush type circuit-breaker for mechanical impact test [C]

Dimensions in millimetres

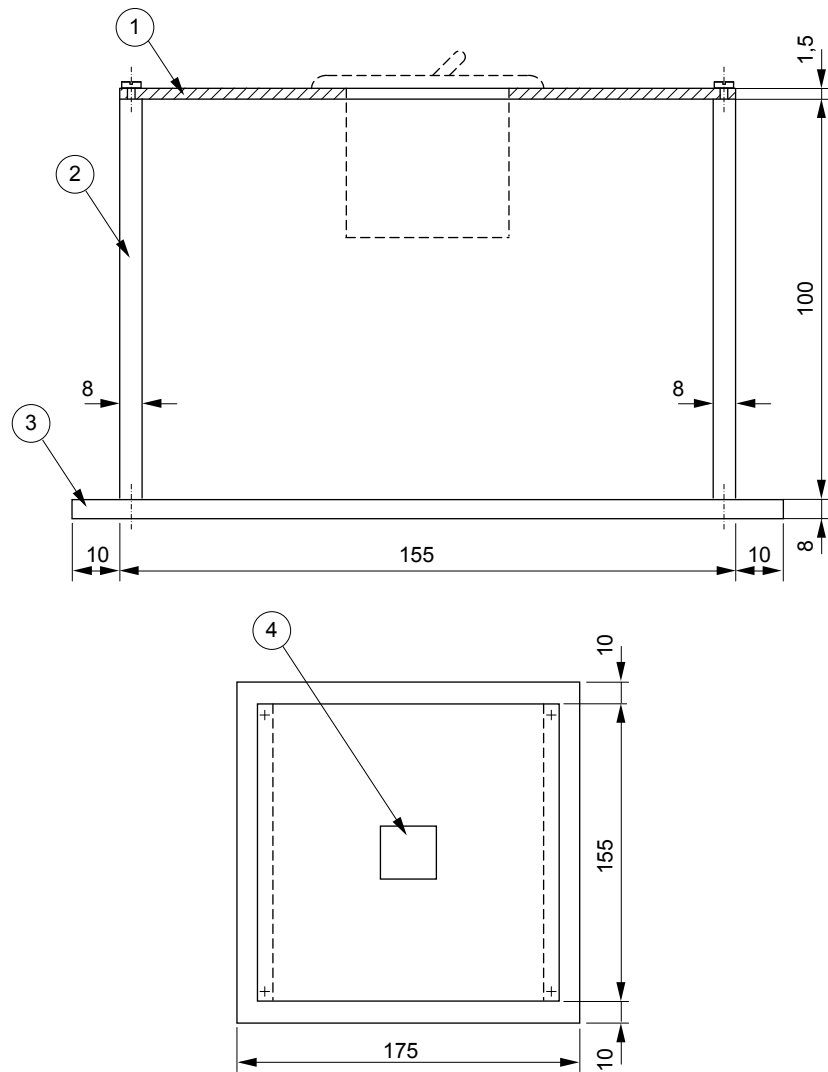

IEC

Key

- 1 Interchangeable steel plate with a thickness of 1,5 mm
- 2 Aluminium plates with a thickness of 8 mm
- 3 Mounting plate
- 4 Cut-out for the circuit-breaker in the steel plate

NOTE In particular cases the dimensions can be increased.

Figure 13 – Example of mounting of a panel board type circuit-breaker for mechanical impact test (9.13.2)

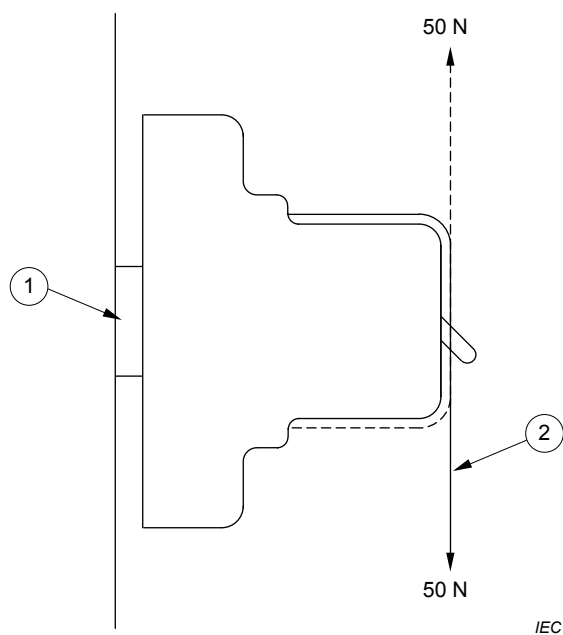
**Key**

- 1 Rail
- 2 Cord

Figure 14 – Application of force for mechanical test on a rail-mounted circuit-breaker (9.13.2.4)

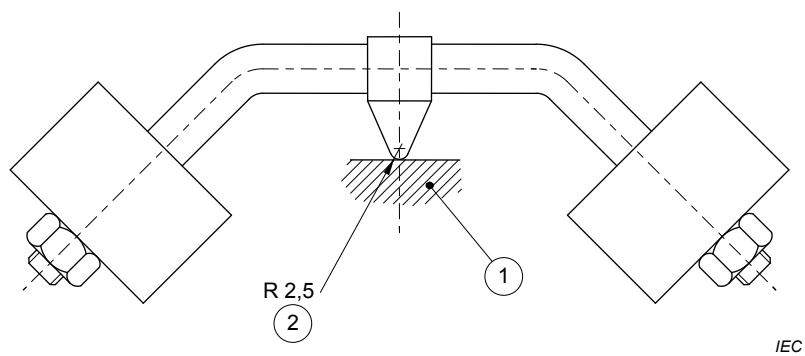
**Key**

- 1 Sample
- 2 Spherical

Figure 15 – Ball-pressure test apparatus

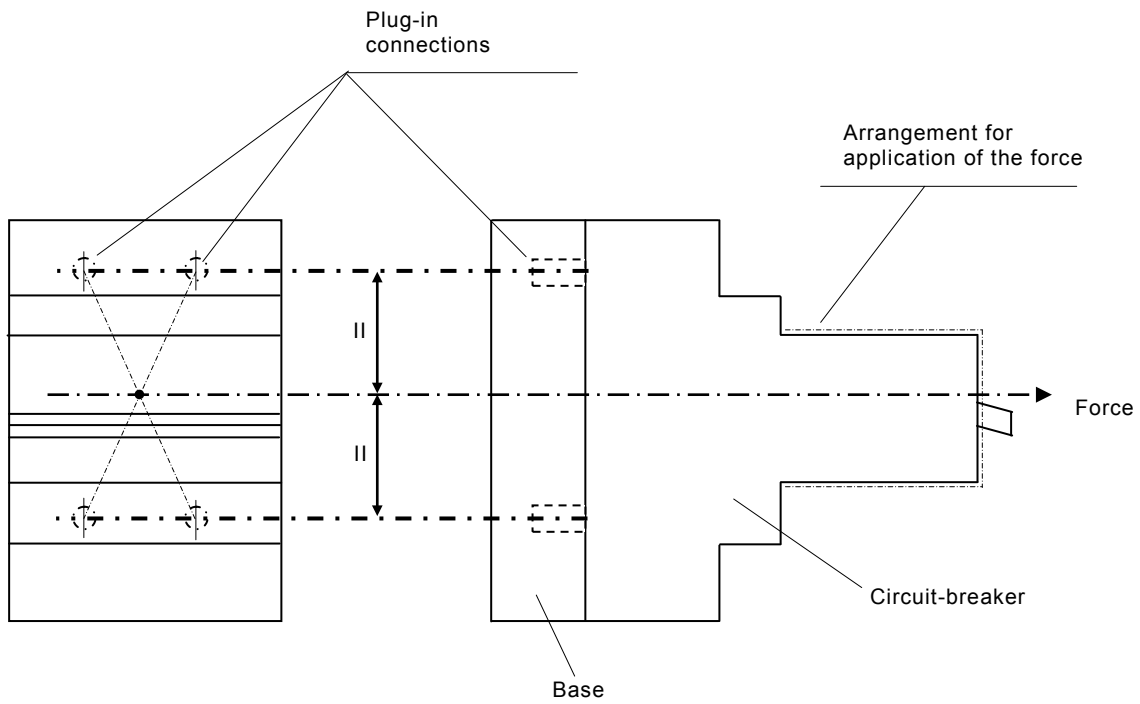

IEC

Figure 16 – Example of application of force for mechanical test on two-pole plug-in circuit-breaker, the holding in position of which depends solely on the plug-in connections (9.13.2.5)

Dimensions in millimetres

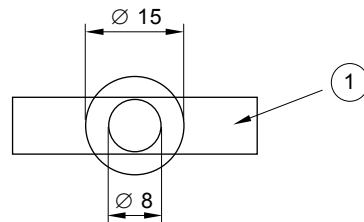

To be tested

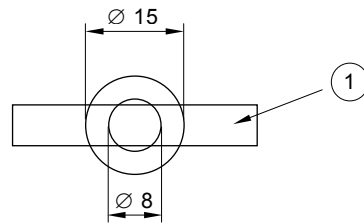

No test is required

IEC

Key

- 1 Sample

Figure 17 – Diagrammatic representation (9.15)

Annex A (informative)

Determination of short-circuit power factor

A.1 General

☐ There is no generally applicable method by which the short-circuit power factor can be determined with precision. Two examples of acceptable methods are given in this Annex A. ☐

A.2 Method 1 – Determination from d.c. component

The angle φ may be determined from the curve of the d.c. component of the asymmetrical current wave between the instant of the short-circuit and the instant of contact separation as follows:

a) The formula for the d.c. component is:

$$i_d = I_{d0} \cdot e^{-Rt/L}$$

where:

- i_d is the value of the d.c. component at the instant t ;
- I_{d0} is the value of the d.c. component at the instant taken as time origin;
- L/R is the time-constant of the circuit, in seconds;
- t is the time, in seconds, taken from the initial instant;
- e is the base of Napierian logarithms.

The time-constant L/R can be ascertained from the above formula as follows:

- measure the value of I_{d0} at the instant of short-circuit and the value of i_d at another instant t before contact separation;
- determine the value of $e^{-Rt/L}$ by dividing i_d by I_{d0} ;
- from a table of values of e^{-x} , determine the value of $-x$ corresponding to the ratio i_d / I_{d0}
- the value x represents Rt/L , from which L/R is obtained.

b) Determine the angle φ from:

$$\varphi = \arctan \omega L/R$$

where ω is 2π times the actual frequency.

This method should not be used when the currents are measured by current transformers.

A.3 Method 2 – Determination with pilot generator

When a pilot generator is used on the same shaft as the test generator, the voltage of the pilot generator on the oscillogram may be compared in phase first with the voltage of the test generator and then with the current of the test generator.

The difference between the phase angles between pilot generator voltage and main generator voltage on the one hand and pilot generator voltage and test generator current on the other hand gives the phase angle between the voltage and current of the test generator, from which the power factor can be determined.

Annex B (normative)

Determination of clearances and creepage distances

B.1 General

In determining clearances and creepage distances, it is recommended that the following points should be considered.

B.2 Orientation and location of a creepage distance

If necessary, the manufacturer shall indicate the intended orientation of the equipment or component in order that creepage distances be not adversely affected by the accumulation of pollution for which they were not designed.

B.3 Creepage distances where more than one material is used

A creepage distance may be split in several portions of different materials and/or have different pollution degrees if one of the creepage distances is dimensioned to withstand the total voltage or if the total distance is dimensioned according to the material having the lowest CTI.

B.4 Creepage distances split by floating conductive part

A creepage distance may be split into several parts, made with insulation material having the same CTI, including or separated by floating conductors as long as the sum of the distances across each individual part is equal or greater than the creepage distance required if the floating part did not exist.

The minimum distance X for each individual part of the creepage distance is given in IEC 60664-1:2007, 6.2 (see also Example 11 in Figure B.1).

B.5 Measurement of creepage distances and clearances

In determining creepage distances according to IEC 60664-1, the dimension X , specified in the following examples, has a minimum value of 1,0 mm for pollution degree 2.

Requirements for arc chambers are covered by Table 4 item j).

If the associated clearance is less than 3 mm, the minimum dimension X may be reduced to one third of this clearance.

The methods of measuring creepage distances and clearances are indicated in Figure B.1. These cases do not differentiate between gaps and grooves or between types of insulation. The following assumptions are made:

- any recess is assumed to be bridged with an insulating link having a length equal to the specified width X and being placed in the most unfavourable position (see Example 3);
- where the distance across a groove is equal to or larger than the specified width X , the creepage distance is measured along the contours of the groove (see Example 2);

Example 5

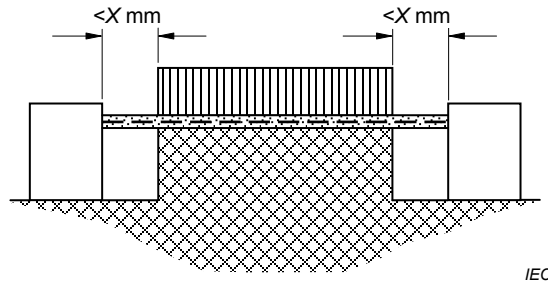

IEC

Condition: Path under consideration includes an uncemented joint with grooves less than X mm wide on each side.

Rule: Creepage and clearance path is the "line of sight" distance shown.

Example 6

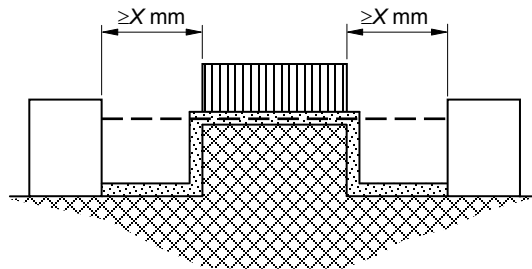

IEC

Condition: Path under consideration includes an uncemented joint with grooves equal to or more than X mm wide on each side.

Rule: Clearance is the "line of sight" distance. Creepage path follows the contour of the grooves.

Example 7

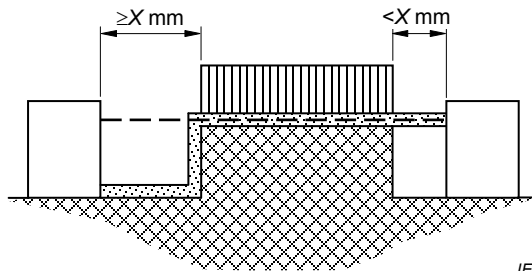

IEC

Condition: Path under consideration includes an uncemented joint with a groove on one side less than X mm wide and the groove on the other side equal to or more than X mm wide.

Rule: Clearance and creepage paths area as shown.

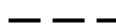

Clearance



Creepage distance

Example 8

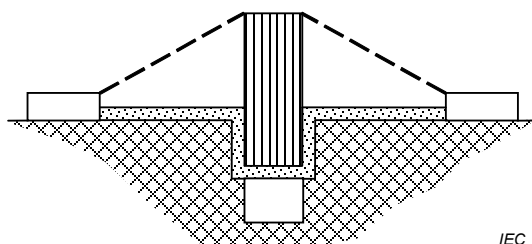

IEC

Condition: Creepage distance through uncemented joint is less than creepage distance over barrier.

Rule: Clearance is the shortest direct air path over the top of the barrier.

Example 9

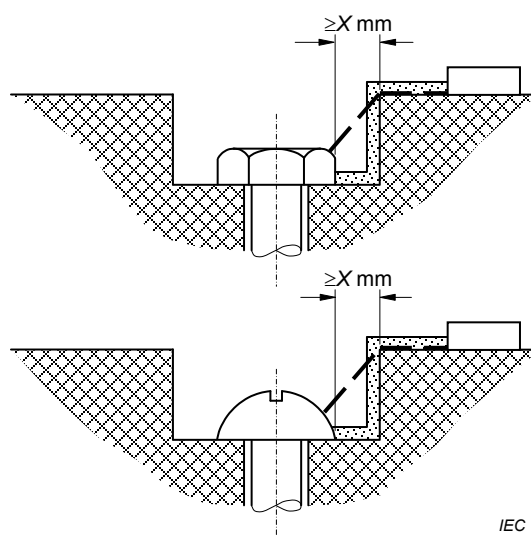

IEC

Gap between head of screw and wall of recess wide enough to be taken into account.

Example 10

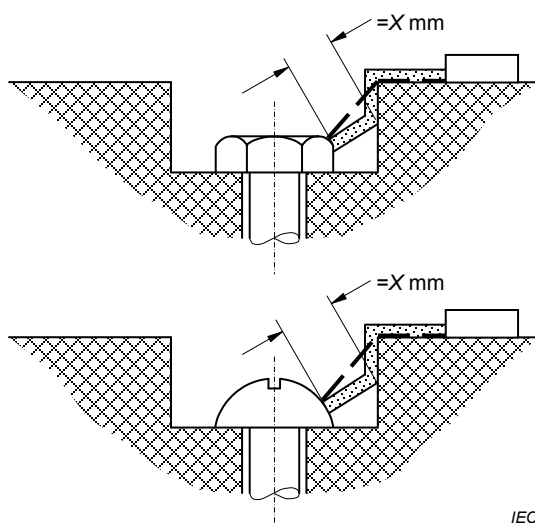

IEC

Gap between head of screw and wall of recess too narrow to be taken into account.

Measurement of creepage distance is from screw to wall when the distance is equal to X mm.

— — — Clearance



Creepage distance

Annex C (normative)

Test sequences and number of samples

C.1 Test sequences

The tests are made according to Table C.1 where the tests in each sequence are carried out in the order indicated.

Table C.1 – Test sequences

Test sequence	Clause or subclause	Test (or inspection)		
A ₁	6	Marking		
	8.1.1	General		
	8.1.2	Mechanism		
	9.3	Indelibility of marking		
	8.1.3	Clearances and creepage distances (external parts only)		
	☐ 8.1.5 ☐	☐ Terminals for external conductors ☐		
	8.1.6	Non-interchangeability		
	9.4	Reliability of screws, current-carrying parts and connections		
	☐ Text deleted ☐	☐ Text deleted ☐		
	9.6	Protection against electric shock		
	8.1.3	Clearances and creepage distances (internal parts only)		
9.14	Resistance to heat			
9.16	Resistance to rusting			
A ₂	9.15	Resistance to abnormal heat and to fire		
B	9.7.5.4	☐ Verification of resistance of the insulation of open contacts against an impulse voltage (suitability for isolation) ☐		
	9.7.1	Resistance to humidity		
	9.7.2	Insulation resistance of the main circuit		
	9.7.3	Dielectric strength of the main circuit		
	9.7.4	Insulation resistance and dielectric strength of auxiliary circuit		
	9.7.5.2	Verification of clearances with the impulse withstand voltage		
	9.8	Temperature rise		
9.9	28-day test			
C	C ₁	9.11	Mechanical and electrical endurance	
		9.12.11.2.1	Performance at reduced short-circuit currents	
		9.12.12	Verification of the circuit-breaker after short-circuit tests	
	C ₂	9.12.11.2.2	Short-circuit test for verifying the suitability of circuit-breakers for use in IT systems	
9.12.12	Verification of the circuit-breaker after short-circuit tests			
D	D ₀	9.10	Tripping characteristic	
	D ₁	9.13	Resistance to mechanical shock and impact	
		9.12.11.3 and 9.12.12	Short-circuit performance at 1 500 A Verification of circuit-breaker after short-circuit tests	
E	E ₁	9.12.11.4.2 and 9.12.12	Service short-circuit capacity (I_{cs}) Verification of circuit-breaker after short-circuit tests	
		9.12.11.4.3 and 9.12.12	Performance at rated short-circuit capacity (I_{cn}) Verification of circuit-breaker after short-circuit tests	
	E ₂	9.12.11.4.3 and 9.12.12	Performance at rated short-circuit capacity (I_{cn}) Verification of circuit-breaker after short-circuit tests	
	E ₃	9.12.11.4.4 and 9.12.12	Performance at rated making and breaking capacity (I_{cn1}) on an individual pole of multipole circuit-breakers	

NOTE With the agreement of the manufacturer the same samples can be used for more than one test sequence.

C.2 Number of samples to be submitted for full test procedure and acceptance criteria

If only one rating (i.e. one set of rated quantities, see 5.2) of one type (number of poles, instantaneous tripping) of circuit-breaker is submitted for test, the number of samples to be submitted to the different test sequences are those indicated in Table C.2 in which the acceptance criteria are given.

If all the samples submitted according to the second column of Table C.2 pass the tests, compliance with the standard is met. If only the minimum number given in the third column passes the tests, additional samples as shown in the fourth column shall be tested and shall satisfactorily complete the test sequence.

For circuit-breakers having more than one rated current, two separate sets of circuit-breakers shall be submitted to each test sequence: one set adjusted at the maximum rated current, the other set at the minimum rated current. In addition one sample of all other rated currents shall be submitted for test sequence D₀ of Table C.1.

Table C.2 – Number of samples for full test procedure

Test sequence	Number of samples	Minimum number of samples which shall pass the tests ^{a b}	Number of samples for repeated tests ^c
A ₁	1	1	–
A ₂	3	2	3
B	3	2	3
C	C ₁	2 ^e	3
	C ₂ ^f	2 ^e	3
D	3	2 ^e	3
E ₁	3 + 3 ^d	2 ^e + 2 ^{d,e}	3 + 3 ^d
E ₂	3 + 4 ^d	2 ^e + 3 ^{d,e}	3 + 4 ^d
E ₃	3	2 ^e	3

^a In total, a maximum of two test sequences may be repeated.

^b It is assumed that a sample which has not passed a test has not met the requirements due to workmanship or assembly defects which are not representative of the design.

^c In the case of repeated tests, all results shall be acceptable.

^d Supplementary samples in the case of single-pole circuit-breakers rated 230/400 V or 240/415 V (see Table 1).

^e All samples shall meet the test requirements of 9.12.10, 9.12.11.2, 9.12.11.3 and 9.12.11.4, as appropriate.

^f For this sequence read "number of protected poles" instead of "number of samples".

C.3 Number of samples to be submitted for simplified test procedure

C.3.1 This part of the standard applies when submitting simultaneously a range of circuit-breakers of the same fundamental design.

C.3.2 For a series of circuit-breakers of the same fundamental design, the number of samples to be tested may be reduced according to C.3.3 and C.3.4.

For subsequent additions (e.g. further values of rated currents, different classification of instantaneous tripping, different number of poles) to such a series of circuit-breakers the same reductions apply.

NOTE When a series of circuit-breakers presenting minor variations with respect to an already approved series of circuit-breakers is submitted to type tests, a further reduction of the number of samples and tests can be agreed upon.

Circuit-breakers can be considered to be of the same fundamental design if the following conditions are met:

- they have the same basic design;
- they have the same external physical dimensions per pole;
- the materials, finish and dimensions of the internal current carrying parts are identical, other than the variations given in a) below;
- the terminals are of similar design, (see d) below);
- the contact size, material, configuration and method of attachment are identical;
- the manual operating mechanisms (materials and physical characteristics) are identical;
- the moulding and insulating materials are identical;
- the method, materials and construction of the arc extinction device are identical;
- the basic design of the overcurrent tripping device is identical, other than the variations given in b) below;
- the basic design of the instantaneous tripping device is identical, other than the variations given in c) below;
- their voltage rating is intended for the same type of distribution circuit (see Table 1);
- multipole circuit-breakers are either composed of single-pole circuit-breakers or built up from the same components as the single-pole circuit-breakers, having the same overall dimensions per pole, with the exception of external barriers between poles.

The following variations are permitted:

- a) cross-sectional areas of the internal current-carrying connections;
- b) dimensions and material of the overcurrent tripping device;
- c) number of turns and cross-sectional area of the operating coil of the instantaneous tripping device;
- d) dimensions of terminals.

C.3.3 For circuit-breakers having the same instantaneous tripping classification according to 4.6 the number of samples to be tested may be reduced, according to Table C.3.

Table C.3 – Reduction of samples for series of circuit-breakers having different numbers of poles

Test sequence	Number of samples depending on number of poles ^a			
	One pole ^b	Two poles ^c	Three poles ^d	Four poles ^e
A ₁	1 maximum rated current	1 maximum rated current ^{g, i}	1 maximum rated current ⁱ	1 maximum rated current ⁱ
A ₂	3 maximum rated current	3 maximum rated current	3 maximum rated current	3 maximum rated current
B	3 maximum rated current	3 maximum rated current ^g	3 maximum rated current	3 maximum rated current
C	C ₁	3 maximum rated current	3 maximum rated current ^g	3 maximum rated current
	C ₂	3 maximum rated current	2 maximum rated current for 2 protected poles, or 3 maximum rated current for one protected pole	1 maximum rated current
D ₀ + D ₁	3 maximum rated current	3 maximum rated current ^h	3 maximum rated current	3 maximum rated current
D ₀	1 of all other rated currents			
E ₁	3+3 ^f maximum rated current	3 maximum rated current	3 maximum rated current	3 maximum rated current
	3+3 ^f minimum rated current	3 minimum rated current	3 minimum rated current	3 minimum rated current
E ₂	3+4 ^f maximum rated current	3 maximum rated current	3 maximum rated current	3 maximum rated current
	3+4 ^f minimum rated current	3 minimum rated current	3 minimum rated current	3 minimum rated current
E ₃	k	3 maximum rated current ^j	3 maximum rated current ^j	3 maximum rated current ^j

^a If a test is to be repeated according to the acceptance criteria of Clause C.2, a new set of samples is used for the relevant test sequence. In repeated tests all results shall be satisfactory.

^b If only multipole circuit-breakers are submitted, this column applies to the set of samples having the smallest number of poles (instead of the relevant column).

^c Applicable to two-pole circuit-breakers whether with two protected poles or with one protected pole.

^d This series is omitted when four-pole circuit-breakers are also tested.

^e Also applicable to circuit-breakers with three protected poles and a neutral pole.

^f Supplementary samples in case of single-pole circuit-breakers of 9.12.11.4.2 d) or 9.12.11.4.3 b).

^g This test sequence is omitted when three-pole or four-pole circuit-breakers have been tested.

^h This test sequence shall be omitted for two-pole circuit breakers with two protected poles, when three-pole or four-pole circuit-breakers have been tested.

ⁱ When multipole circuit-breakers are submitted, a maximum of four screw-type terminals for external conductors are subjected to the tests of 9.5, i.e. two supply and two load terminals.

^j If each pole of the multipole is identical to the individual pole tested in E₂, this test is omitted. If not, this test is carried out on an individual protected pole, taken at random, of the circuit-breaker with the highest number of poles.

^k Covered by test sequence E₂.

C.3.4 For an additional series of circuit-breakers of the same fundamental design as described in C.3.2 but of a different instantaneous tripping classification according to 4.6 the test sequences to be applied may be limited to those given in Table C.4, the number of samples being those given in Table C.3.

**Table C.4 – Test sequences for a series of circuit-breakers
being of different instantaneous tripping classifications**

Circuit-breaker type- tested first	Subsequent test sequences for circuit-breakers of		
	B-type	C-type	D-type
B-type	–	$(D_0 + D_1) + E$	$(D_0 + D_1) + E$
C-type	$D_0^a + B^a$		$(D_0 + D_1) + E$
D-type	$D_0^a + B^a$	$D_0^a + B^{a b}$	–

^a For these test sequences only the tests of 9.8 and 9.10.3 are required.

^b When conformity assessment is requested at the same time for B-type, C-type and D-type circuit-breakers having the same rated short-circuit capacity, only test sequence D_0 is required if B-type and D-type samples have been tested.

Annex D (informative)

Co-ordination under short-circuit conditions between a circuit-breaker and another short-circuit protective device (SCPD) associated in the same circuit

D.1 General

To ensure co-ordination under short-circuit conditions between a circuit-breaker (C_1) and another short-circuit protective device (SCPD) associated with it in the same circuit, it is necessary to consider the characteristics of each of the two devices as well as their behaviour as an association.

NOTE An SCPD can incorporate additional protective means, for example overload releases.

The SCPD may consist of a fuse (or a set of fuses), see Figure D.1, or another circuit-breaker (C_2) (see Figures D.2 and D.3).

The comparison of the individual operating characteristics of each of the two associated devices may not be sufficient, when reference has to be made to the behaviour of these two devices operating in series, since the impedance of the devices is not always negligible. It is recommended that this should be taken into account. For short-circuit currents it is recommended that reference be made to I^2t instead of time.

C_1 is frequently connected in series with another SCPD for reasons such as the method of power distribution adopted for the installation or because the short-circuit capacity of C_1 alone may be insufficient for the proposed application. In such instances the SCPD may be mounted in locations remote from C_1 . The SCPD may be protecting a main feeder supplying a number of circuit-breakers C_1 or just an individual circuit-breaker.

For such applications the user or specifying authority may have to decide, on the basis of a desk study alone, how the optimum level of co-ordination may best be achieved. This Annex D is intended to give guidance for this decision, and also on the type of information which the circuit-breaker manufacturer should make available to the prospective user.

Guidance is also given on test requirements, where such tests are deemed necessary for the proposed application.

The term "co-ordination" includes consideration of selectivity (see 3.5.14.2 and also 3.5.14.4 and 3.5.14.5) as well as consideration of back-up protection (see 3.5.14.3).

Consideration of selectivity can in general be carried out by desk study (see Clause D.5) whereas the verification of back-up protection normally requires the use of tests (see Clause D.6).

When considering short-circuit breaking capacity, reference is made to the rated short-circuit capacity (I_{cn}) of C_1 and C_2 when both are circuit-breakers according to IEC 60898-1, and to the ultimate short-circuit breaking capacity (I_{cu}) of C_2 , when C_2 is a circuit-breaker according to IEC 60947-2.

D.2 Overview

This Annex D gives guidance on and requirements for the co-ordination of a circuit-breaker with other SCPDs associated in the same circuit, as regards selectivity as well as back-up protection.

The object of this Annex D is to state

- the general requirements for the co-ordination of a circuit-breaker with another SCPD;
- the methods and the tests (if deemed necessary) intended to verify that the conditions for co-ordination have been met.

D.3 General requirements for the co-ordination of a circuit-breaker with another SCPD

D.3.1 General consideration

Ideally, the co-ordination should be such that a circuit-breaker (C_1) alone will operate at all values of overcurrent up to the limit of its rated short-circuit capacity I_{cn} .

NOTE If the value of the prospective fault current at the point of installation is less than the rated short-circuit capacity of C_1 , it can be assumed that the SCPD is only in the circuit for considerations other than that of back-up protection.

In practice the following considerations apply:

- a) if the value of the selectivity limit current I_s (see 3.5.14.6) is too low, there is a risk of unnecessary loss of selectivity;
- b) if the value of the prospective fault current at the point of installation exceeds the rated short-circuit capacity of C_1 , the SCPD shall be so selected that the behaviour of C_1 is in accordance with D.3.3 and the take-over current I_B (see 3.5.14.7), if any, complies with the requirements of D.3.2.

Whenever possible, the SCPD shall be located on the supply side of C_1 . If the SCPD is located on the load side, it is essential that the connection between C_1 and the SCPD be so arranged as to minimize any risk of short-circuit.

D.3.2 Take-over current

For the purpose of back-up protection the take-over current I_B shall not exceed the rated short-circuit capacity I_{cn} of C_1 alone (see Figure D.3a).

D.3.3 Behaviour of C_1 in association with another SCPD

For all values of overcurrent up to and including the short-circuit capacity of the association, C_1 and the association shall comply with the requirements of 8.8.

D.4 Type and characteristics of the associated SCPD

On request, the manufacturer of the circuit-breaker shall provide information on the type and the characteristics of the SCPD to be used with C_1 , and on the maximum prospective short-circuit current for which the association is suitable at the stated operational voltage.

Details of the SCPD used for any tests made in accordance with this Annex D, i.e. manufacturer's name, type designation, rated voltage, rated current and short-circuit breaking capacity, shall be given in the test report.

The maximum conditional short-circuit current I_{nc} (see 3.5.14.8) shall not exceed

- the rated ultimate breaking capacity of the SCPD, if this is a circuit-breaker according to IEC 60947-2;
- the rated short-circuit capacity, if the SCPD is a circuit-breaker according to this standard;
- the rated short-circuit breaking capacity, if the SCPD is a fuse.

If the associated SCPD is a circuit-breaker, it shall meet the requirements of this standard, or any other relevant standard.

If the associated SCPD is a fuse, it shall be in accordance with IEC 60269 series or with any other fuse standard.

D.5 Verification of selectivity

Selectivity can normally be considered by desk study alone, i.e. by a comparison of the operating characteristics of C_1 and the associated SCPD, for example when the associated SCPD is a circuit-breaker (C_2) provided with an intentional time-delay.

The manufacturers of both the C_1 and the SCPD shall provide adequate data concerning the relevant operating characteristics as to permit I_s to be determined for each individual association.

In certain cases, tests at I_s are necessary on the association, for example:

- when C_1 is of the current limiting type and C_2 is not provided with an intentional time-delay;
- when the opening time of the SCPD is less than that corresponding to one half-cycle.

To obtain the desired selectivity when the associated SCPD is a circuit-breaker, an intentional short-time delay may be necessary for C_2 .

Selectivity may be partial (see Figure D.3a) or total up to the rated short-circuit capacity I_{cn} of C_1 . For total selectivity, the non-tripping characteristic of C_2 or the pre-arcing characteristic of the fuse shall lie above the tripping (break time) characteristic of C_1 .

Two illustrations of total selectivity are given in Figures D.2a and D.2b.

D.6 Verification of back-up protection

D.6.1 Determination of the take-over current

Compliance with the requirements of D.3.2 can be checked by comparing the operating characteristics of C_1 with those of the associated SCPD for all settings (if any) of C_2 .

D.6.2 Verification of back-up protection

D.6.2.1 Verification by tests

Compliance with the requirements of D.3.3 is normally verified by tests in accordance with D.6.3. In this case, all conditions for the tests shall be as specified in 9.12.11.4.3 with the adjustable resistors and inductors for the short-circuit tests on the supply side of the association.

NOTE An example of a test circuit is shown in Figure 3.

D.6.2.2 Verification by comparison of characteristics

In some practical cases and where the SCPD is a circuit-breaker (see Figure D.3a and D.3b), it may be possible to compare the operating characteristics of C_1 and of the associated SCPD, special attention being paid to the following:

- the Joule integral value of C_1 at its I_{cn} and that of SCPD at the prospective current of the association;

- the effects on C_1 (e.g. by arc energy, maximum peak current, cut-off current) at the peak operating current of the SCPD.

The suitability of the association may be evaluated by considering the maximum operating I^2t characteristic of the SCPD, over the range from the rated short-circuit capacity I_{cn} of C_1 up to the prospective short-circuit current of the application, but not exceeding the maximum let-through I^2t of C_1 at its rated short-circuit capacity or other lower limiting value stated by the manufacturer.

NOTE Where the associated SCPD is a fuse, the validity of the desk study is limited to I_{cn} of C_1 .

D.6.3 Tests for verification of back-up protection

If the associated SCPD is a circuit-breaker (C_2) fitted with adjustable overcurrent opening releases, the operating characteristics to be used shall be those corresponding to the maximum time and maximum current settings.

If the associated SCPD consists of a set of fuses, each test shall be made using a new set of fuses, even if some of the fuses used during a previous test have not blown.

Where applicable, the connecting cables shall be included as specified in 9.12.4 except that, if the associated SCPD is a circuit-breaker (C_2), the full length of cable (75 cm) associated with this circuit-breaker may be on the supply side.

Each test shall consist of a O-t-CO sequence of operation made in accordance with 9.12.11.4.3 at I_{cn} , the CO operation being made on C_1 .

A test is made with the maximum prospective current for the proposed application. This shall not exceed the rated conditional short-circuit current (see 3.5.14.9).

A further test shall be made at a value of prospective current equal to the rated short-circuit breaking capacity I_{cn} of C_1 , for which test a new sample C_1 may be used, and also, if the associated SCPD is a circuit-breaker, a new sample C_2 .

During each operation

a) if the associated SCPD is a circuit-breaker (C_2):

- either both C_1 and C_2 shall trip at both test currents, no further tests then being required.

This is the general case in which back-up protection only is provided.

- or C_1 shall trip and C_2 shall be in the closed position at the end of each operation, at both test currents, no further tests then being required.

This requires that the contacts of C_2 separate momentarily during each operation. In this case restoration of the supply is provided, in addition to back-up protection (see note 1 to Figure D.3a). The duration of interruption of supply, if any, shall be recorded during these tests.

- or C_1 shall trip at the lower test current, and both C_1 and C_2 shall trip at the higher test current.

This requires that the contacts of C_2 separate momentarily at the lower test current. Additional tests shall be made at intermediate currents to determine the lowest current at which both C_1 and C_2 trip, up to which current restoration of supply is provided. The duration of interruption of supply, if any, shall be recorded during these tests.

b) if the associated SCPD is a fuse (or a set of fuses) as declared by the manufacturer:

- for the test at the rated conditional short-circuit current
- in case of a single-phase circuit at least one fuse shall blow;

- in case of a multi-phase circuit either two or more fuses shall blow, or one fuse shall blow and C_1 shall trip;
- for the test at the rated short-circuit breaking capacity C_1 shall trip and at least one fuse shall blow.

D.6.4 Results to be obtained

Following the tests, C_1 shall comply with 9.12.12.2.

In addition, if the associated SCPD is a circuit-breaker (C_2), it shall be verified, by manual operation or other appropriate means, that the contacts of C_2 have not welded.

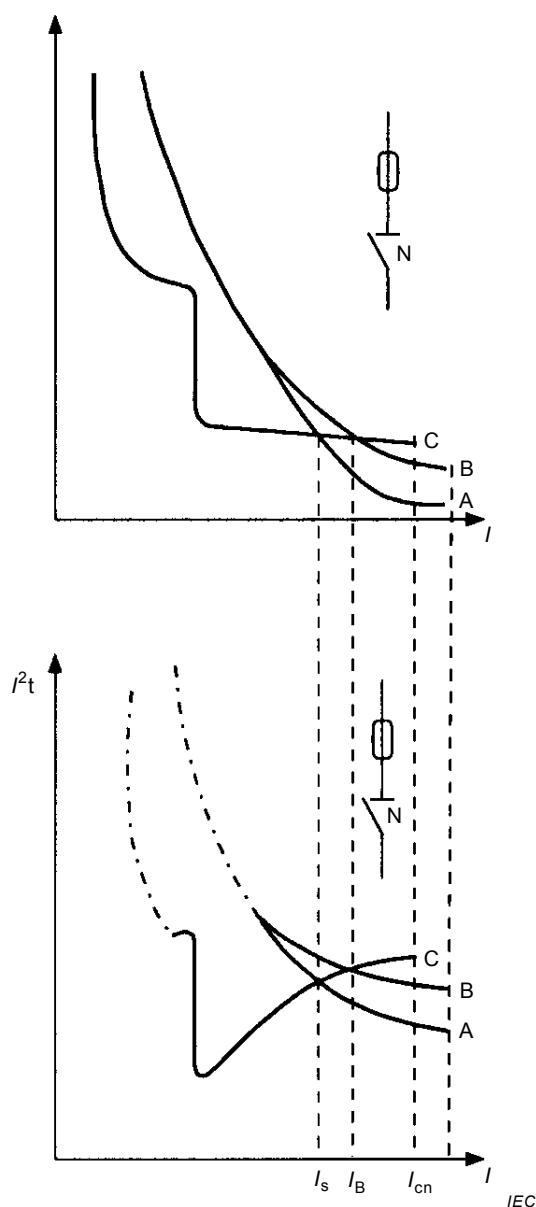

Key

- I = Prospective short-circuit current
- I_{cn} = Rated short-circuit capacity (5.2.4)
- I_s = Selectivity limit current (3.5.14.5)
- I_B = Take-over current (3.5.14.7)
- A = Pre-arcing characteristic of the fuse
- B = Operating characteristic of the fuse
- C = Operating characteristic of the circuit-breaker, non-current-limiting (N) (break-time/current and I^2t /current)

NOTE 1 A is deemed to be the lower limit; B and C are deemed to be the upper limits.

NOTE 2 Non-adiabatic zone for I^2t shown chain-dotted.

NOTE 3 Reproduced from IEC 60947-2: 2006 Figure A.1.

Figure D.1 – Overcurrent co-ordination between a circuit-breaker and a fuse or back-up protection by a fuse – Operating characteristics

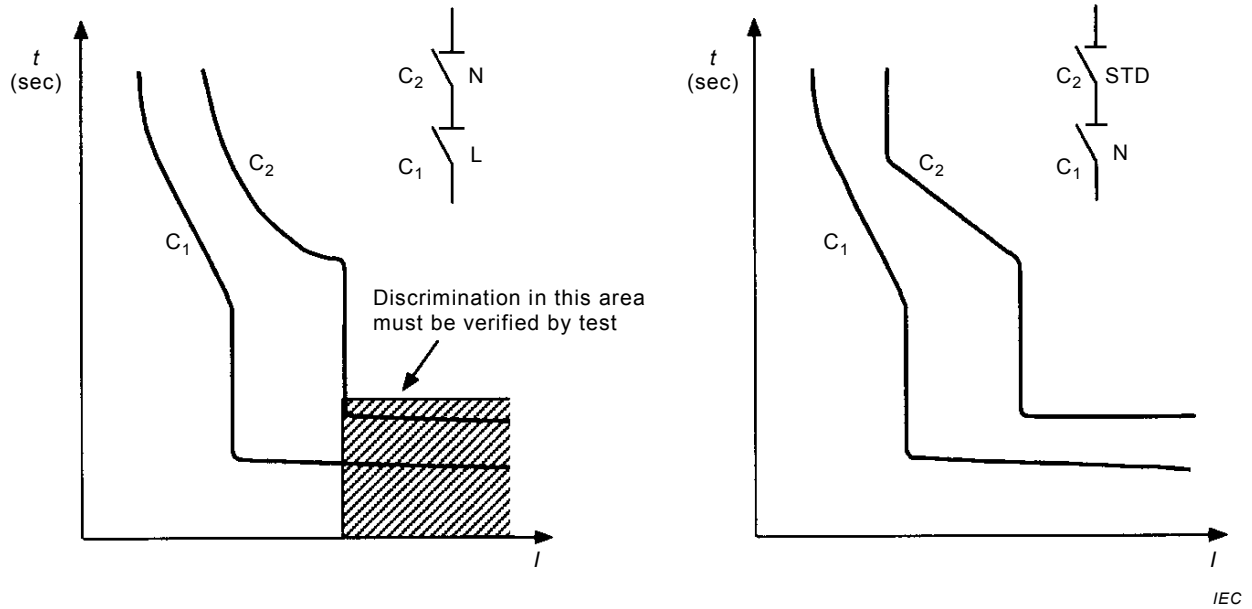

Key

C₁ = Current-limiting circuit-breaker (L)
(break-time characteristic)

C₂ = Non-current-limiting circuit breaker (N)
(tripping characteristic)

NOTE Values of I_{cn} are not shown.

C₁ = Non-current-limiting circuit-breaker (N)
(break-time characteristic)

C₂ = Circuit-breaker with intentional short-time
delay (STD) (tripping characteristic)

Figure D.2a

Figure D.2b

Figure D.2 – Total selectivity between two circuit-breakers

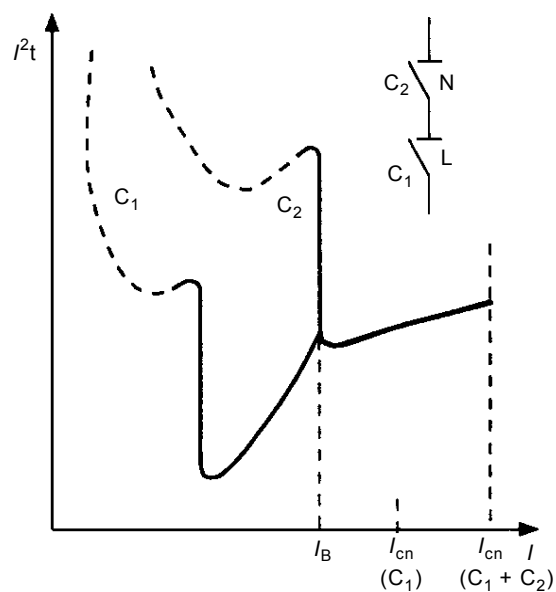
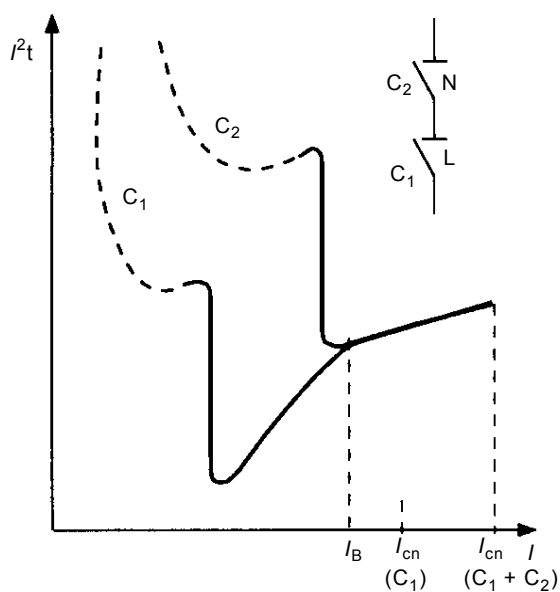
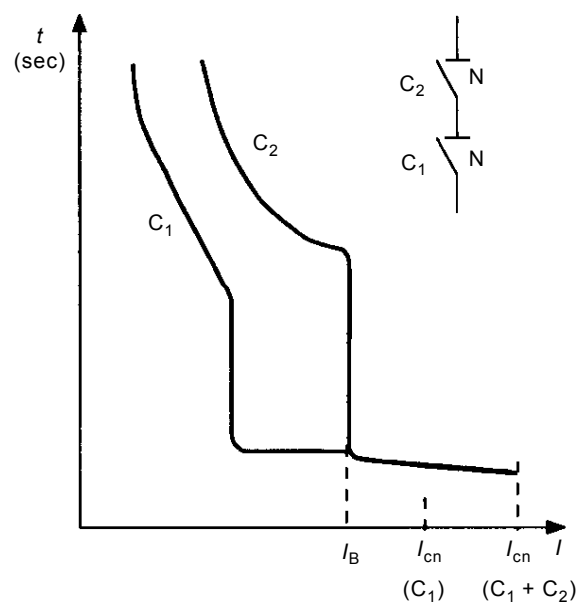
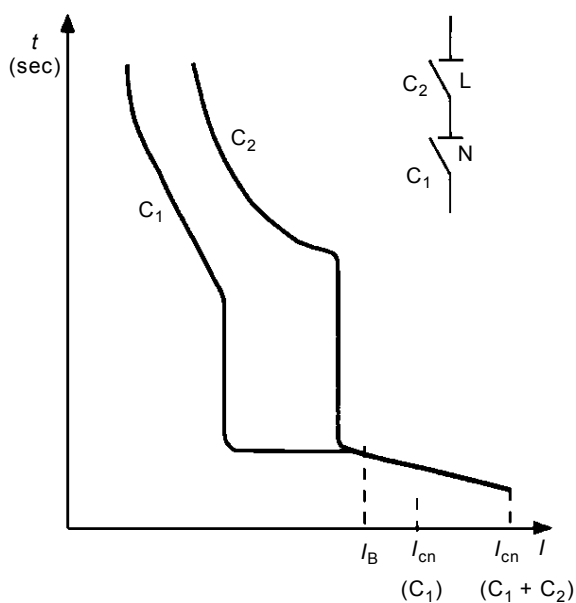

IEC

Figure D.3a

Figure D.3b

Key C_1 = Non current-limiting circuit-breaker (N) C_1, C_2 = Non current-limiting circuit-breaker (N) C_2 = Current-limiting circuit breaker (L) I_B = Take-over currentNOTE 1 Where applicable, restoration of supply by C_2 occurs.NOTE 2 $I_{cn}(C_1 + C_2) \leq I_{cn}(C_2)$.NOTE 3 For values of $I > I_B$, the curve is that of the association (shown in bold) for which data are obtained by tests.**Figure D.3 – Back-up protection by a circuit-breaker – Operating characteristics**

Annex E

(void)

☐ *Text deleted* ☐

Annex F (informative)

Examples of terminals

In Figures F.1 to F.4 examples of designs of terminals are given. The conductor location shall have a diameter suitable for accepting solid rigid conductors and a cross-sectional area suitable for accepting rigid stranded conductors (see 8.1.5).

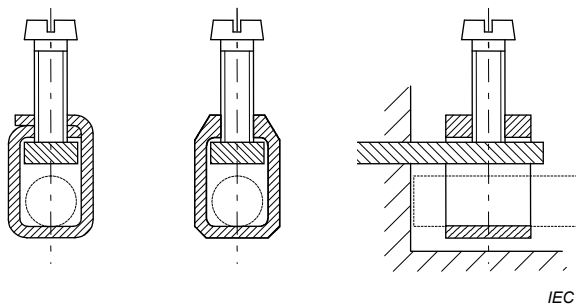

Figure F.1a – Terminals with stirrup

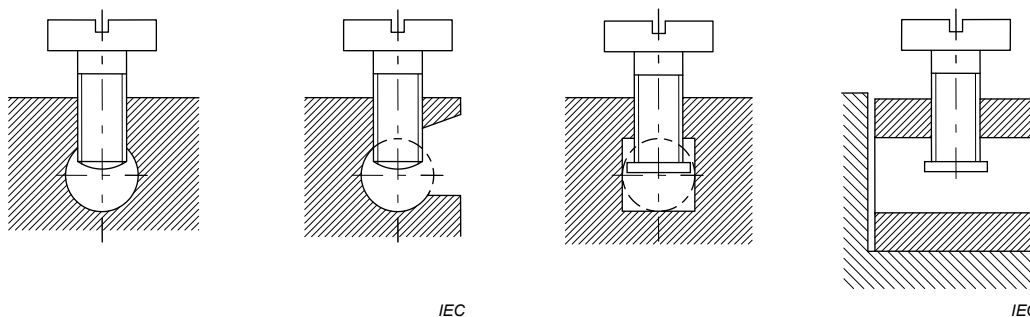

Figure F.1b – Terminals without
pressure plate

Figure F.1c – Terminals with
pressure plate

The part of the terminal containing the threaded hole and the part of the terminal against which the conductor is clamped by the screw may be two separate parts, as in the case of a terminal provided with a stirrup.

Figure F.1 – Examples of pillar terminals

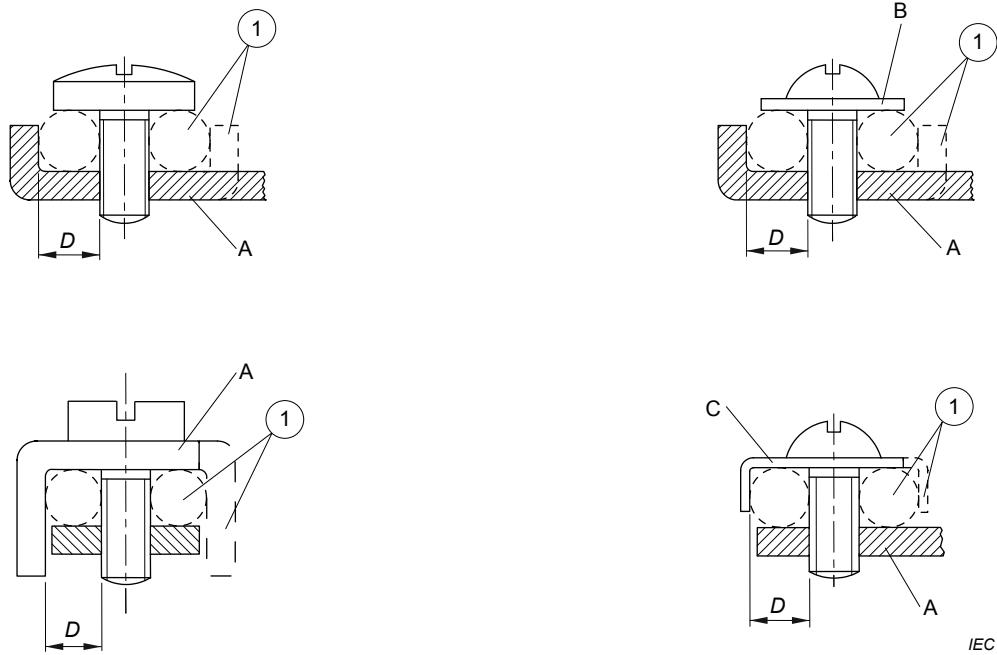

Figure F.2a – Screw terminals

Screw not requiring washer or clamping plate

Screw requiring washer, clamping plate or anti-spread device



Figure F.2b – Stud terminals

Key

- 1 Optional
- A Fixed part
- B Washer or clamping plate
- C Anti-spread device
- D Conductor space
- E Stud

The part which retains the conductor in position may be of insulating material, provided the pressure necessary to clamp the conductor is not transmitted through the insulating material.

Figure F.2 – Examples of screw terminals and stud terminals

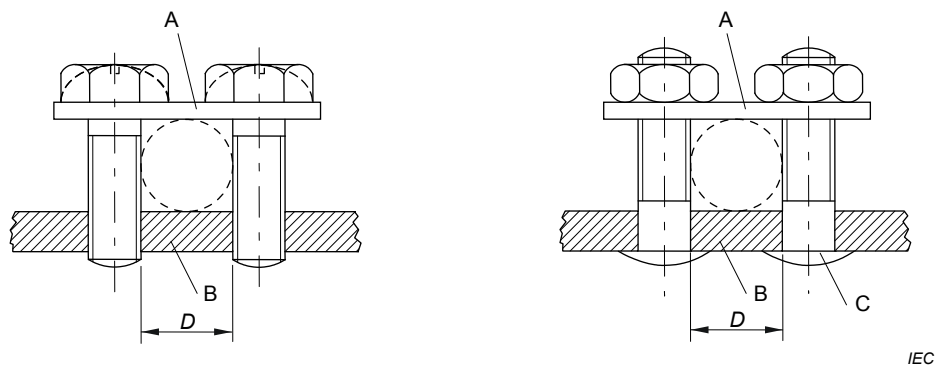

IEC

Key

- A Saddle
- B Fixed part
- C Stud
- D Conductor space

The two faces of the saddle may be of different shapes to accommodate conductors of either small or large cross-sectional area, by inverting the saddle.

The terminals may have more than two clamping screws or studs.

Figure F.3 – Examples of saddle terminals

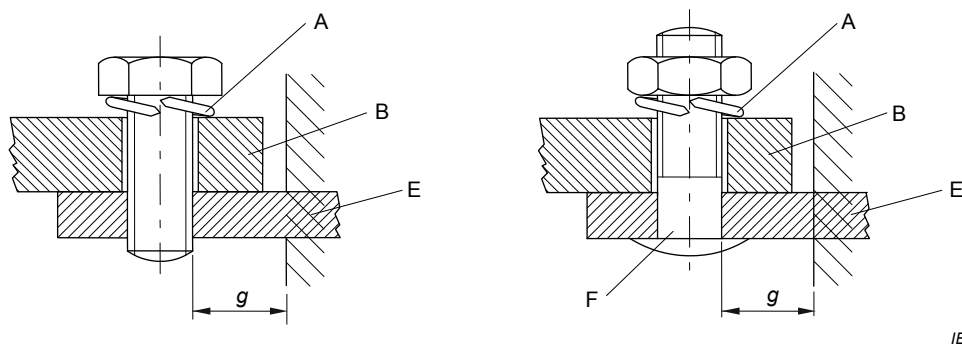

IEC

Key

- A Locking means
- B Cable lug or bar
- E Fixed part
- F Stud

For this type of terminal, a spring washer or equally effective locking means shall be provided and the surface within the clamping area shall be smooth.

For certain types of equipment, the use of lug terminals of sizes smaller than that required is allowed.

Figure F.4 – Examples of lug terminals

Annex G

(void)

☐ *Text deleted* ☐

Annex H (normative)

Arrangement for short-circuit test

The device under test is mounted as shown in Figure H.1 which may require adapting to the specific design of the device, and in accordance with the manufacturer's instruction.

When required (i.e. during O operations), a clear polyethylene foil ($0,05 \pm 0,01$) mm, of a size at least 50 mm larger in each direction, than the overall dimensions of the front face of the device, but not less than 200×200 mm, is fixed and reasonably stretched in a frame, placed at a distance of 10 mm from

- either the maximum projection of the operating means of a device without recess for the operating means;
- or the rim of a recess for the operating means of a device with recess for the operating means.

The foil should have the following physical properties:

- density at 23 °C: ($0,92 \pm 0,05$) g/cm³;
- melting point: (110 to 120) °C.

When required, a barrier of insulating material, at least 2 mm thick, is placed, as shown in Figure H.1, between the arc vent and the polyethylene foil to prevent damage of the foil due to hot particles emitted from the arc vent.

When required, a grid, (or grids) according to Figure H.2 is (are) placed at a distance of "a" (mm) \overline{C} from \overline{C} each arc vent of the device.

The grid circuit (see Figure H.3) shall be connected to the points B or C or C', as applicable (see Figures 3 and 4).

The parameters for the grid circuit(s) are as follows:

- resistor R': 1,5 Ω ;
- copper wire F': length 50 mm and diameter as specified in 9.12.9.2.

Dimensions in millimetres

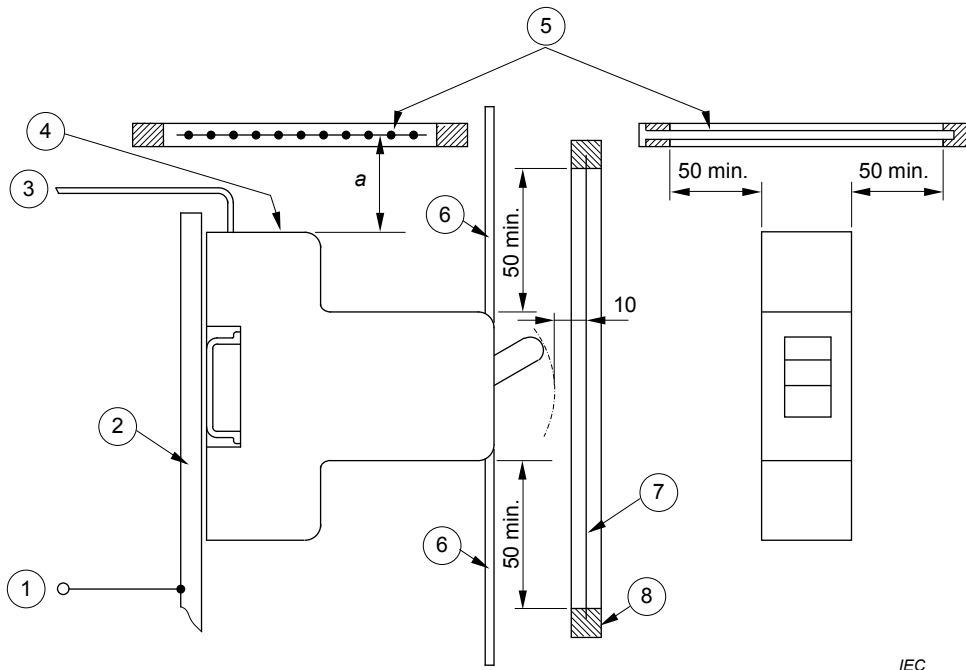

IEC

Key

- 1 To the fuse F
- 2 Metal plate
- 3 Cable
- 4 Arc vent
- 5 Grid [C] (position is given as an example) [C]
- 6 Barrier
- 7 Polyethylene sheet
- 8 Frame

Figure H.1 – Test arrangement

Dimension in millimetres

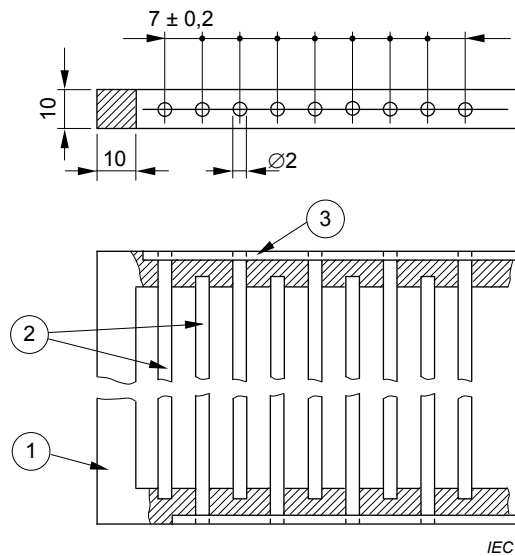

IEC

Key

- 1 Frame of insulating material
- 2 Copper wires
- 3 Metal interconnection of copper wires

Figure H.2 – Grid circuit

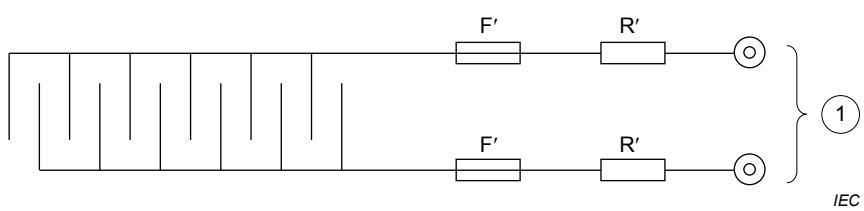
**Key**

1 Connected to points B and C

Figure H.3 – Grid circuit

Annex I **(normative)**

Routine tests

I.1 General

The tests specified in this Annex I are intended to reveal, as far as safety is concerned, unacceptable variations in material or manufacture.

Further tests may have to be made, according to the experience gained by the manufacturer, to ensure that every circuit-breaker is in conformity with the samples which passed the tests of this standard.

I.2 Tripping tests

Tripping test shall be verified according to a) and b).

a) Verification of the time-current characteristic

A current of any convenient value between the conventional tripping current and the lower value of the range of instantaneous tripping of Table 2 (according to the tripping characteristic of the circuit-breaker: B, C or D) is passed separately through each protected pole starting from cold.

The circuit-breaker shall trip within a time corresponding to a point, selected by the manufacturer, situated between the limiting times of the tripping characteristic.

b) Verification of the instantaneous tripping

☐ The test is carried out at any convenient voltage without necessarily blocking the operating mean in the closed position. The test may be carried out on each protected pole separately. ☐

I.3 Verification of clearances between open contacts

With the circuit-breaker in the open position a voltage of substantially sine-wave form of 1 500 V, having a frequency of 50 Hz or 60 Hz, is applied for 1 s between the terminals which are electrically connected together when the circuit-breaker is in the closed position.

No flashover or breakdown shall occur.

Alternatively any convenient method of verification of the clearances between open contacts (e.g. X-ray verification) may be used.

Annex J (normative)

Particular requirements for circuit-breakers with screwless type terminals for external copper conductors

NOTE This annex supplements or modifies the corresponding clauses in this standard. Where this annex states “addition”, “modification” or “replacement”, the relevant requirements, test specifications or explanatory matter in this standard should be adapted accordingly.

J.1 Scope

This Annex J applies to circuit-breakers within the scope of this standard, equipped with screwless terminals, for current not exceeding 20 A primarily suitable for connecting unprepared (see J.3.6) copper conductors of cross-section up to 4 mm².

 Text deleted 

In this Annex J, screwless terminals are referred to as terminals and copper conductors are referred to as conductors.

J.2 Normative references

Clause 2 applies.

J.3 Terms and definitions

Clause 3 applies with the following exceptions:

Additional terms and definitions:

J.3.1 clamping units

parts of the terminal necessary for mechanical clamping and the electrical connection of the conductors including the parts which are necessary to ensure correct contact pressure

J.3.2 screwless-type terminal

terminal for the connection and subsequent disconnection obtained directly or indirectly by means of springs, wedges or the like

Note 1 to entry: Examples are given in Figure J.2.

J.3.3 universal terminal

terminal for the connection and disconnection of all types of conductors (rigid and flexible)

 Text deleted 

J.3.4 non-universal terminal

terminal for the connection and disconnection of a certain kind of conductor only (e.g. rigid-solid conductors only or rigid-[solid or stranded] conductors only)

J.3.5**push-wire terminal**

non-universal terminal in which the connection is made by pushing-in rigid (solid or stranded) conductors

J.3.6**unprepared conductor**

conductor which has been cut and the insulation of which has been removed over a certain length for insertion into a terminal

Note 1 to entry: A conductor the shape of which is arranged for introduction into a terminal or of which the strands may be twisted to consolidate the end, is considered to be an unprepared conductor.

Note 2 to entry: The term "unprepared conductor" means conductor not prepared by soldering of the wire, use of cable lugs, formation of eyelets, etc., but includes its reshaping before introduction into the terminal or, in the case of flexible conductor, by twisting it to consolidate the end.

J.4 Classification

Clause 4 applies.

J.5 Characteristics of circuit-breakers

Clause 5 applies.

J.6 Marking

Clause 6 applies with the following exceptions:

Additional requirements:

Universal terminals:

- no marking.

Non-universal terminals:

- terminals declared for rigid-solid conductors shall be marked by the letters "sol";
- terminals declared for rigid (solid and stranded) conductors shall be marked by the letter "r";
- terminals declared for flexible conductors shall be marked by the letter "f".

The markings should appear on the circuit-breaker or, if the space available is not sufficient, on the smallest package unit or in technical information .

An appropriate marking indicating the length of insulation to be removed before insertion of the conductor into the terminal shall be shown on the circuit-breaker.

The manufacturer shall also provide information, in his literature, on the maximum number of conductors which may be clamped.

J.7 Standard conditions for operation in service

Clause 7 applies.

J.8 Constructional requirements

Clause 8 applies, with the following exceptions.

In 8.1.5 only 8.1.5.1, 8.1.5.2, 8.1.5.3, 8.1.5.6 and 8.1.5.7 apply.

Compliance is checked by inspection and by the tests of J.9.1 and J.9.2 of this Annex J, instead of 9.4 and 9.5.

Additional subclauses:

J.8.1 Connection or disconnection of conductors

The connection or disconnection of conductors shall be made

- by the use of a general purpose tool or by a convenient device integral with the terminal to open it and to assist the insertion or the withdrawal of the conductors (e.g. for universal terminals);

or, for rigid conductors

- by simple insertion. For the disconnection of the conductors an operation other than a pull on the conductor shall be necessary (e.g. for push-wire terminals).

Universal terminals shall accept rigid (solid or stranded) and flexible unprepared conductors.

Non-universal terminals shall accept the types of conductors declared by the manufacturer.

Compliance is checked by inspection and by the tests of J.9.1 and J.9.2.

J.8.2 Dimensions of connectable conductors

The dimensions of connectable conductors are given in Table J.1.

The ability to connect these conductors shall be checked by inspection and by the tests of J.9.1 and J.9.2.

Table J.1 – Connectable conductors

Connectable conductors and their theoretical diameter									
Metric					AWG				
Rigid			Flexible		Rigid			Flexible	
	Solid	Stranded				Solid ^a	Class B stranded ^a		Classes I, K, M, stranded
mm ²	∅ mm	∅ mm	mm ²	∅ mm	gauge	∅ mm	∅ mm	gauge	∅ mm
1,0	1,2	1,4	1,0	1,5	18	1,02	1,16	18	1,28
1,5	1,5	1,7	1,5	1,8	16	1,29	1,46	16	1,60
2,5	1,9	2,2	2,5	2,3	14	1,63	1,84	14	2,08
4,0	2,4	2,7	4,0	2,9	12	2,05	2,32	12	2,70

NOTE Diameters of the largest rigid and flexible conductors are based on Table 1 of IEC 60228:2004., and, for AWG conductors, on ASTM B 172-71, and ICEA publications S-19-81, S-66-524 and S-68-516.

^a Nominal diameter + 5 %.

^b Largest diameter + 5 % for any of the three classes I, K and M.

J.8.3 Connectable cross-sectional areas

The nominal cross-sections to be clamped are defined in Table J.2.

Table J.2 – Cross-sections of copper conductors connectable to screwless-type terminals

Rated current A	Nominal cross-sections to be clamped mm ²
Up to and including 13	1 up to and including 2,5
Above 13 up to and including 20	1,5 up to and including 4

Compliance is checked by inspection and by the tests of J.9.1 and J.9.2.

J.8.4 Insertion and disconnection of conductors

The insertion and disconnection of the conductors shall be made in accordance with the manufacturer's instructions.

Compliance is checked by inspection.

J.8.5 Design and construction of terminals

Terminals shall be so designed and constructed that:

- each conductor is clamped individually;
- during the operation of connection or disconnection the conductors can be connected or disconnected either at the same time or separately;
- inadequate insertion of the conductor is avoided.

It shall be possible to clamp securely any number of conductors up to the maximum provided for.

Compliance is checked by inspection and by the tests of J.9.1 and J.9.2.

J.8.6 Resistance to ageing

The terminals shall be resistant to ageing.

Compliance is checked by the test of J.9.3.

J.9 Tests

Clause 9 applies with the following exceptions:

Replacement of 9.4 and 9.5 by the following new subclauses:

J.9.1 Test of reliability of screwless terminals

J.9.1.1 Reliability of screwless system

The test is carried out on three terminals of poles of new samples, with copper conductors of the rated cross sectional area in accordance with Table J.2. The types of conductors shall be in accordance with J.8.1.

The connection and subsequent disconnection shall be made five times with the smallest diameter conductor and successively five times with the largest diameter conductor.

New conductors shall be used each time, except for the fifth time, when the conductor used for the fourth insertion is clamped at the same place. Before insertion into the terminal, wires of stranded rigid conductors shall be re-shaped and wires of flexible conductors shall be twisted to consolidate the ends.

For each insertion, the conductors are either pushed as far as possible into the terminal or shall be inserted so that adequate connection is obvious.

After each insertion, the conductor being inserted is rotated 90° along its axis at the level of the clamped section and subsequently disconnected.

After these tests, the terminal shall not be damaged in such a way as to impair its further use.

J.9.1.2 Test of reliability of connection

Three terminals of poles of new samples are fitted with new copper conductors of the type and of the rated cross sectional area according to Table J.2.

The types of conductors shall be in accordance with J.8.1.

Before insertion into the terminal, wires of stranded rigid conductors and flexible conductors shall be reshaped and wires of flexible conductors shall be twisted to consolidate the ends.

It shall be possible to fit the conductor into the terminal without undue force in the case of universal terminals and with the force necessary by hand in the case of push-wire terminals.

The conductor is either pushed as far as possible into the terminal or shall be inserted so that adequate connection is obvious.

After the test, no wire of the conductor shall have escaped outside the terminal.

J.9.2 Tests of reliability of terminals for external conductors: mechanical strength

For the pull-out test three terminals of poles of new samples are fitted with new conductors of the type and of the minimum and maximum cross-sectional areas according to Table J.2.

Before insertion into the terminal, wires of stranded rigid conductors and flexible conductors shall be reshaped and wires of flexible conductors shall be twisted to consolidate the ends.

Each conductor is then subjected to a pull force of the value shown in Table J.3. The pull is applied without jerks for 1 min in the direction of the axis of the conductor.

Table J.3 – Pull forces

Cross-sectional area mm ²	Pull force N
1,0	35
1,5	40
2,5	50
4,0	60

During the test the conductor shall not slip out of the terminal.

J.9.3 Cycling test

The test is made with new copper conductors having cross section according to Table 10.

The test is carried out on new samples (a sample is one pole), the number of which is defined below, according to the type of terminals:

- universal terminals for rigid (solid and stranded) and flexible conductors: 3 samples each (6 samples in total);
- non-universal terminals for solid conductors only: 3 samples;
- non-universal for rigid (solid and stranded) conductors: 3 samples each (6 samples);

NOTE In case of rigid conductors, solid conductors should be used (if solid conductors are not available in a given country, stranded conductors can be used).

- non-universal for flexible conductors only: 3 samples.

The conductor is connected in series as in normal use to each of the three samples as defined on Figure J.1.

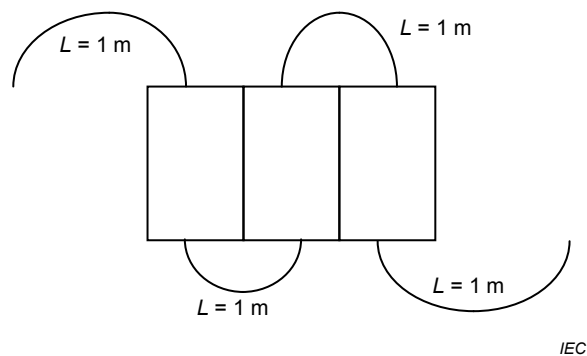

IEC

Figure J.1 – Connecting samples

The sample is provided with a hole (or equivalent) in order to measure the voltage drop on the terminal.

The whole test arrangement, including the conductors, is placed in a heating cabinet which is initially kept at a temperature of $(20 \pm 2) ^\circ\text{C}$.

To avoid any movement of the test arrangement until all the following voltage drop tests have been completed it is recommended that the poles are fixed on a common support.

Except during the cooling period, a test current corresponding to the rated current of the circuit breaker is applied to the circuit.

The samples shall be then subjected to 192 temperature cycles, each cycle having a duration of approximately 1 h, as follows:

The air temperature in the cabinet is raised to $40 ^\circ\text{C}$ in approximately 20 min. It is maintained within $\pm 5 ^\circ\text{C}$ of this value for approximately 10 min.

The samples are then allowed to cool down in approximately 20 min to a temperature of approximately $30 ^\circ\text{C}$, forced cooling being allowed. They are kept at this temperature for approximately 10 min and, if necessary for measuring the voltage drop, allowed to cool down further, to a temperature of $(20 \pm 2) ^\circ\text{C}$.

The maximum voltage drop, measured at each terminal, at the end of the 192nd cycle, with the nominal current shall not exceed the smaller of the two following values:

- either 22,5 mV,
- or 1,5 times the value measured after the 24th cycle.

The measurement shall be made as near as possible to the area of contact on the terminal.

If the measuring points cannot be positioned closely to the point of contact, the voltage drop within the part of the conductor between the ideal and the actual measuring points shall be deducted from the voltage drop measured.

The temperature in the heating cabinet must be measured at a distance of at least 50 mm from the samples.

After this test an inspection with the naked eye, by normal or corrected vision, without additional magnification, shall show no changes evidently impairing further use, such as cracks, deformations or the like.

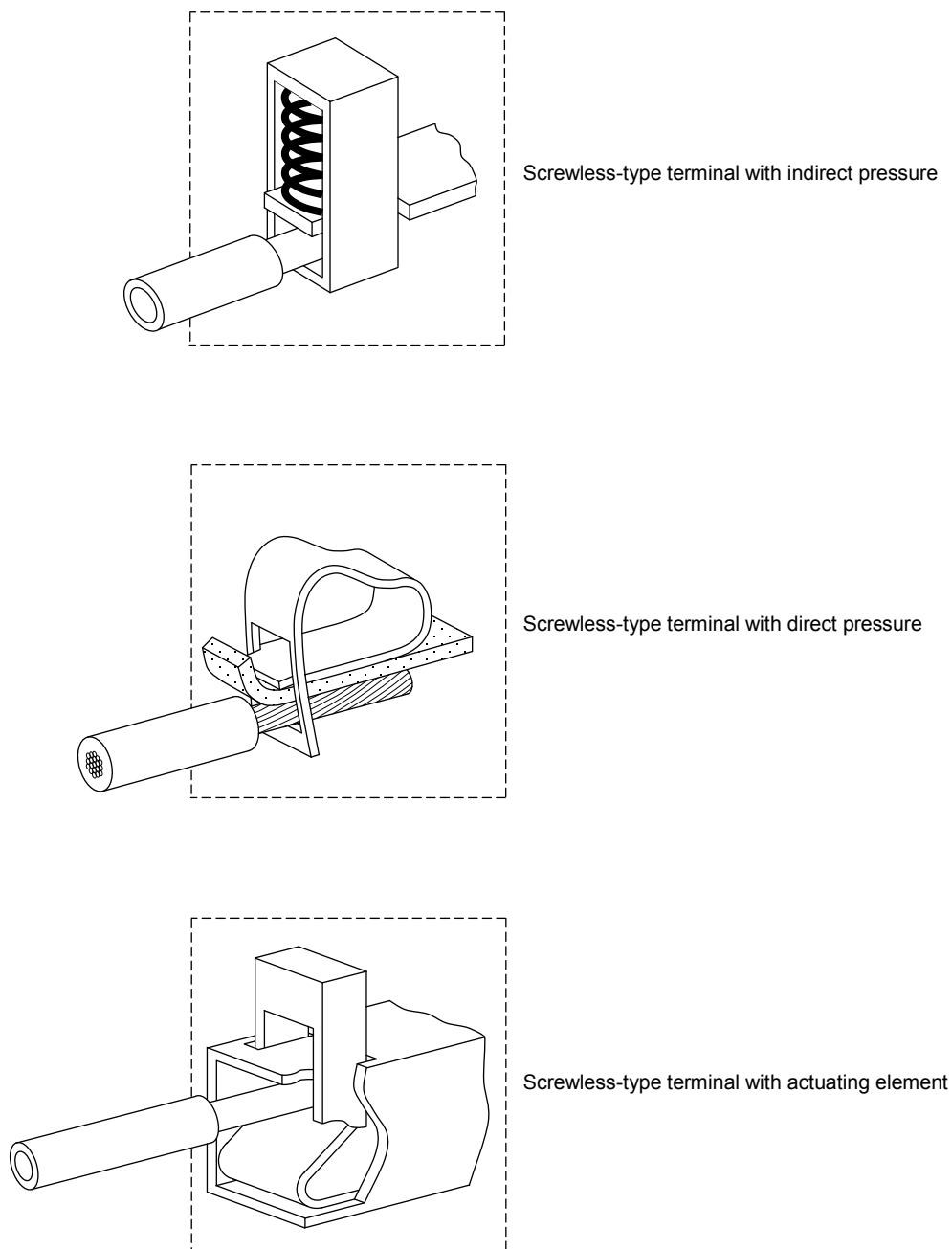

IEC

Figure J.2 – Examples of screwless-type terminals**J.10 Reference documents**

IEC 60228:2004, *Conductors of insulated cables*

IEC 60998-1:1990, *Connecting devices for low voltage circuits for household and similar purposes – Part 1: General requirements*

IEC 60998-2-2:1991, *Connecting devices for low-voltage circuits for household and similar purposes – Part 2-2: Particular requirements for connecting devices as separate entities with screwless-type clamping units*

IEC 60999 (all parts), *Connecting devices – Electrical copper conductors – Safety requirements for screw-type and screwless-type clamping units*

ASTM B172-01a, *Standard Specification for Rope-Lay-Stranded Copper Conductors Having Bunch-Stranded Members, for Electrical Conductors*

ICEA S-19-81 / NEMA WC3, *Rubber-Insulated Wire and Cable*¹

ICEA S-66-524 / NEMA WC7, *Cross-Linked-Thermosetting-Polyethylene Insulated Wire and Cable*¹

ICEA S-68-516 / NEMA WC8, *Ethylene-Propylene-Rubber Insulated Wire and Cable*¹

¹ Withdrawn

Annex K (normative)

Particular requirements for circuit-breakers with flat quick-connect terminations

NOTE This annex supplements or modifies the corresponding clauses in this standard. Where this annex states "addition", "modification" or "replacement", the relevant requirements, test specifications or explanatory matter in this standard should be adapted accordingly.

K.1 Scope

This Annex K applies to circuit-breakers within the scope of clause 1, equipped with flat quick-connect terminations consisting of a male tab (see K.3.2) with nominal width 6,3 mm and thickness 0,8 mm, to be used with a mating female connector for connecting electrical copper conductors according to the manufacturer's instructions, for rated currents up to and including 16 A.

☐ Text deleted ☐

The connectable electrical copper conductors are flexible, having a cross-sectional area up to and including 4 mm², or rigid stranded, having a cross-sectional area up to and including 2,5 mm² (AWG equal to or greater than 12).

This Annex K applies exclusively to circuit-breakers having male tabs as an integral part of the device.

K.2 Normative references

Clause 2 applies with the following exceptions:

Additional reference:

IEC 61210:1993, *Connecting devices – Flat quick-connect terminations for electrical copper conductors – Safety requirements*

K.3 Terms and definitions

Clause 3 applies with the following exceptions:

Additional terms and definitions:

K.3.1

flat quick-connect termination

electrical connection consisting of a male tab and a female connector which can be pushed into and withdrawn with or without the use of a tool

K.3.2

male tab

portion of a quick-connect termination which receives the female connector

K.3.3

female connector

portion of a quick-connect termination which is pushed onto the male tab

**K.3.4
detent**

dimple (depression) or hole in the male tab which engages a raised portion on the female connector to provide a latch for the mating parts.

K.4 Classification

Clause 4 applies.

K.5 Characteristics of circuit-breakers

Clause 5 applies.

K.6 Marking

Clause 6 applies with the following exceptions:

Addition after the lettered item k):

The following information regarding the female connector according to IEC 61210 and the type of conductor to be used shall be given in the manufacturers' instructions:

- a) manufacturer's name or trade mark;
- b) type reference;
- c) information on cross-sections of conductors and colour code of insulated female connectors (see Table K.1 below);
- d) the use of only silver or tin-plated copper alloys.

**Table K.1 – Informative table on colour code of female connectors
in relationship with the cross section of the conductor**

Cross-section of the conductor mm ²	Colour code of the female connector
1	Red
1,5	Red or blue
2,5	Blue or yellow
4	Yellow

K.7 Standard conditions for operation in service

Clause 7 applies.

K.8 Constructional requirements

Clause 8 applies, with the following exceptions:

Replacement of 8.1.3 by:

K.8.1 Clearances and creepage distances (see Annex B)

Subclause 8.1.3 applies, the female connectors being fitted to the male tabs of the circuit-breaker.

Replacement of 8.1.5 by:

K.8.2 Terminals for external conductors

K.8.2.1 Male tabs and female connectors shall be of a metal having mechanical strength, electrical conductivity and resistance to corrosion adequate for their intended use.

NOTE Silver or tin plated copper alloys are examples of suitable solutions.

K.8.2.2 The nominal width of the male tab is 6,3 mm and the thickness 0,8 mm, applicable to rated currents up to and including 16 A.

 *Text deleted* 

The dimensions of the male tab shall comply with those specified in Table K.3 and in figures K.2, K.3, K.4 and K.5, where the dimensions A, B, C, D, E, F, J, M, N and Q are mandatory.

The dimensions of the female connector which may be fitted-on are given in Figure K.6 and in Table K.4.

NOTE The shapes of the various parts may deviate from those given in the figures, provided that the specified dimensions are not influenced and the test requirements are complied with, for example: corrugated tabs, folded tabs, etc.

Compliance is checked by inspection and by measurement.

K.8.2.3 Male tabs shall be securely retained.

Compliance is checked by the mechanical overload test of K.9.1.

K.9 Tests

Clause 9 applies, with the following exceptions:

Replacement of 9.5 by:

K.9.1 Mechanical overload-force

This test is done on 10 terminals of circuit-breakers, mounted as in normal use when wiring takes place.

The axial push force, and successively the axial pull force specified in the following Table K.2, are gradually applied to the male tab integrated in the circuit-breaker, once only with a suitable test apparatus.

Table K.2 – Overload test forces

Push N	Pull N
96	88

No damage which could impair further use shall occur to the tab or to the circuit-breaker in which the tab is integrated.

Addition to 9.8.3:

Fine-wire thermocouples shall be placed in such a way as not to influence the contact or the connection area. An example of placement is shown in Figure K.1.

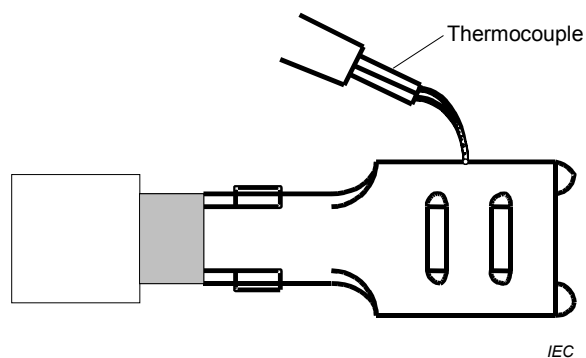

Figure K.1 – Example of position of the thermocouple for measurement of the temperature-rise

Table K.3 – Dimensions of tabs

Dimensions in millimetres

Nominal size		A	B min	C	D	E	F	J	M	N	P	Q min
6,3 × 0,8	Dimple	1,0		0,84	6,40	4,1	2,0	12°	2,5	2,0	1,8	
		0,7	7,8	0,77	6,20	3,6	1,6	8°	2,2	1,8	0,7	8,9
	Hole	1,0		0,84	6,40	4,7	2,0	12°			1,8	
		0,5	7,8	0,77	6,20	4,3	1,6	8°			0,7	8,9

NOTE 1 For the dimensions A to Q refer to figures K.2 to K.5.

NOTE 2 Where two values are shown in one column, they give the maximum and the minimum dimension.

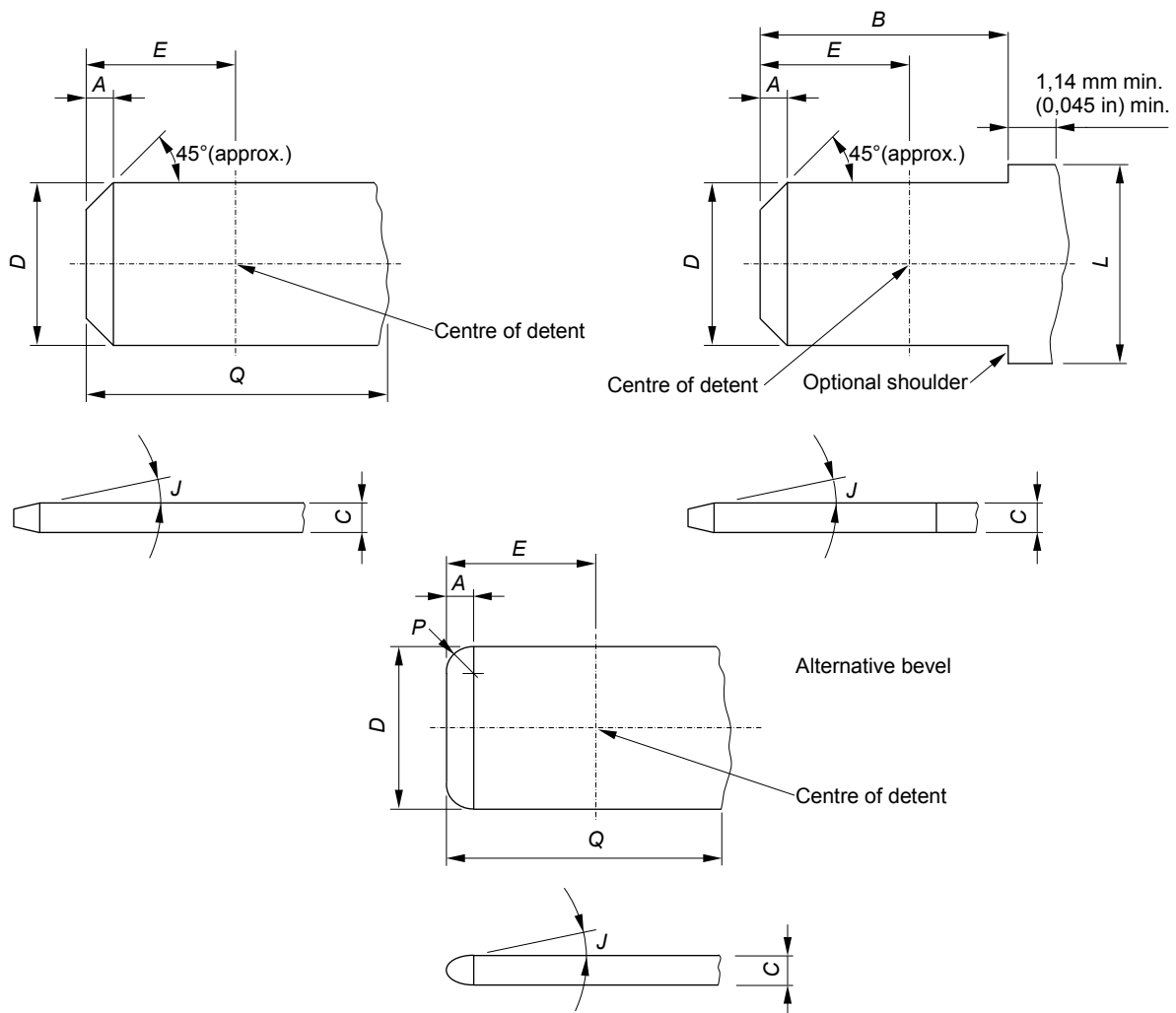

IEC

NOTE 1 Bevel A of 45° need not be a straight line if it is within the confines shown.

NOTE 2 Dimension L is not specified and may vary by the application (for example fixing).

NOTE 3 Dimension C of tabs may be produced from more than one layer of material provided that the resulting tab complies in all respects with the requirements of this standard.

A radius on the longitudinal edge of the tab is permissible.

NOTE 4 The sketches are not intended to govern the design except with regard to the dimensions shown.

NOTE 5 The thickness C of the male tab may vary beyond Q or beyond $B + 1,14 \text{ mm}$ (0,043 in)

NOTE 6 All portions of the tabs are flat and free of burrs or raised plateaus, except that there may be a raised plateau over the stock thickness of 0,025 mm (0,001 in) per side, in an area defined by a line surrounding the detent and distant from it by 1,3 mm (0,051 in).

Figure K.2 – Dimensions of male tabs

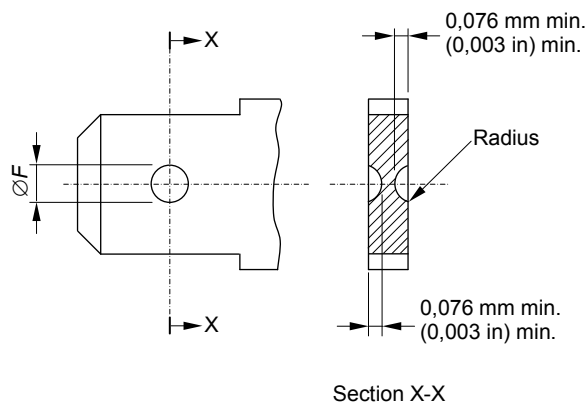

Detent shall be located within 0,076 mm (0,003 in) of the centre-line of the tab.

Figure K.3 – Dimensions of round dimple detents (see Figure K.2)

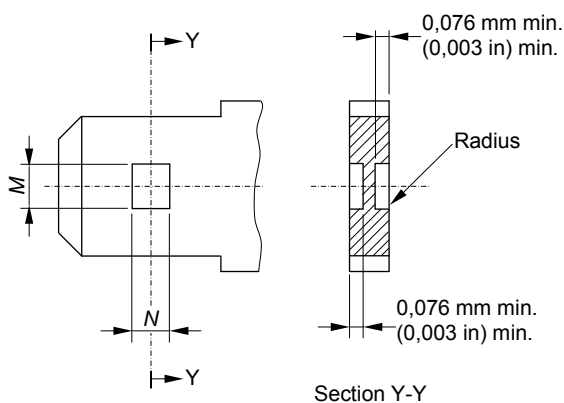

Detent shall be located within 0,13 mm (0,005 in) of the centre-line of the tab.

Figure K.4 – Dimensions of rectangular dimple detents (see Figure K.2)

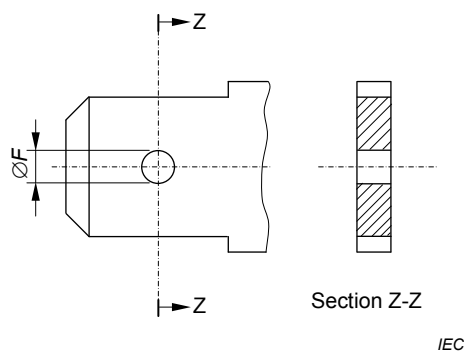

Detent shall be located within 0,076 mm (0,003 in) of the centre-line of the tab.

Figure K.5 – Dimensions of hole detents

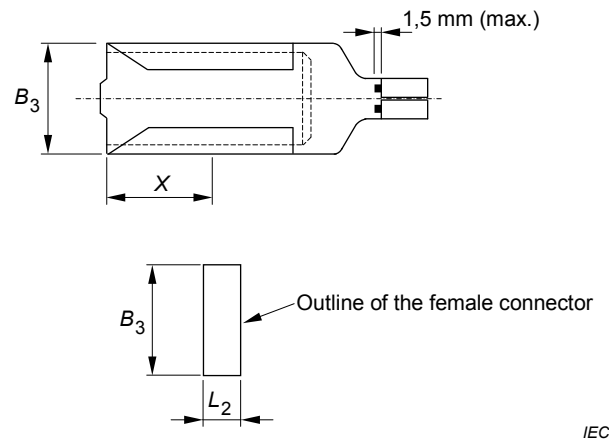

Dimensions B_3 and L_2 are mandatory.

NOTE 1 For determining female connector dimensions varying from B_3 and L_2 refer to the tab dimensions in order to ensure that in the most onerous conditions the engagement (and detent, if fitted) between tab and female connector is correct.

NOTE 2 If a detent is provided, the dimension X is at manufacturer's discretion in order to meet the requirements of the performance clauses.

NOTE 3 Female connectors are so designed that undue insertion of the conductor into the crimping area is visible or prevented by a stop in order to avoid any interference between the conductor and a fully inserted tab.

NOTE 4 The sketches are not intended to govern the design except as regards the dimensions shown.

Figure K.6 – Dimensions of female connectors

Table K.4 – Dimensions of female connectors

Tab size mm	Dimensions of female connector mm	
	B_3 max.	L_2 max.
6,3 × 0,8	7,8	3,5

K.10 Reference documents

IEC 60760:1989, *Flat, quick-connect terminations*

Annex L
(void)

☐ *Text deleted* ☐

Bibliography

IEC 60038, *IEC standard voltages*

IEC 60228A:1982, *First supplement to Publication 228, Conductors of insulated cables – Guide to the dimensional limits of circular conductors*

IEC 60060-1:1989, *High-voltage test techniques – Part 1: General definitions and test requirements*

IEC 60112, *Method for determining the comparative and the proof tracking indices of solid insulating materials under moist conditions*

IEC 60364-1, *Low-voltage electrical installations – Part 1: Fundamental principles, assessment of general characteristics, definitions*

IEC 60898-2:1996, *Circuit-breakers for overcurrent protection for household and similar installations – Part 2: Circuit-breakers for a.c. and d.c. operation*

IEC 61009-1:1996, *Residual current operated circuit-breakers with integral overcurrent protection for household and similar uses (RCBO's) – Part 1: General rules*

IEC 61009-2-1:1991, *Residual current operated circuit-breakers with integral overcurrent protection for household and similar use (RCBO's) – Part 2-1: Applicability of the general rules to RCBO's functionally independent of line voltage*

IEC 61009-2-2:1991, *Residual current operated circuit-breakers with integral overcurrent protection for household and similar uses (RCBO's) – Part 2-2: Applicability of the general rules to RCBO's functionally dependent on line voltage*

ISO 2039-2:1987, *Plastics – Determination of hardness – Part 2: Rockwell hardness*

ISO/IEC Guide 2:1991, *General terms and their definitions concerning standardization and related activities*

British Standards Institution (BSI)

BSI is the national body responsible for preparing British Standards and other standards-related publications, information and services.

BSI is incorporated by Royal Charter. British Standards and other standardization products are published by BSI Standards Limited.

About us

We bring together business, industry, government, consumers, innovators and others to shape their combined experience and expertise into standards-based solutions.

The knowledge embodied in our standards has been carefully assembled in a dependable format and refined through our open consultation process. Organizations of all sizes and across all sectors choose standards to help them achieve their goals.

Information on standards

We can provide you with the knowledge that your organization needs to succeed. Find out more about British Standards by visiting our website at bsigroup.com/standards or contacting our Customer Services team or Knowledge Centre.

Buying standards

You can buy and download PDF versions of BSI publications, including British and adopted European and international standards, through our website at bsigroup.com/shop, where hard copies can also be purchased.

If you need international and foreign standards from other Standards Development Organizations, hard copies can be ordered from our Customer Services team.

Copyright in BSI publications

All the content in BSI publications, including British Standards, is the property of and copyrighted by BSI or some person or entity that owns copyright in the information used (such as the international standardization bodies) and has formally licensed such information to BSI for commercial publication and use.

Save for the provisions below, you may not transfer, share or disseminate any portion of the standard to any other person. You may not adapt, distribute, commercially exploit, or publicly display the standard or any portion thereof in any manner whatsoever without BSI's prior written consent.

Storing and using standards

Standards purchased in soft copy format:

- A British Standard purchased in soft copy format is licensed to a sole named user for personal or internal company use only.
- The standard may be stored on more than 1 device provided that it is accessible by the sole named user only and that only 1 copy is accessed at any one time.
- A single paper copy may be printed for personal or internal company use only.
- Standards purchased in hard copy format:
- A British Standard purchased in hard copy format is for personal or internal company use only.
- It may not be further reproduced – in any format – to create an additional copy. This includes scanning of the document.

If you need more than 1 copy of the document, or if you wish to share the document on an internal network, you can save money by choosing a subscription product (see 'Subscriptions').

Reproducing extracts

For permission to reproduce content from BSI publications contact the BSI Copyright & Licensing team.

Subscriptions

Our range of subscription services are designed to make using standards easier for you. For further information on our subscription products go to bsigroup.com/subscriptions.

With **British Standards Online (BSOL)** you'll have instant access to over 55,000 British and adopted European and international standards from your desktop. It's available 24/7 and is refreshed daily so you'll always be up to date.

You can keep in touch with standards developments and receive substantial discounts on the purchase price of standards, both in single copy and subscription format, by becoming a **BSI Subscribing Member**.

PLUS is an updating service exclusive to BSI Subscribing Members. You will automatically receive the latest hard copy of your standards when they're revised or replaced.

To find out more about becoming a BSI Subscribing Member and the benefits of membership, please visit bsigroup.com/shop.

With a **Multi-User Network Licence (MUNL)** you are able to host standards publications on your intranet. Licences can cover as few or as many users as you wish. With updates supplied as soon as they're available, you can be sure your documentation is current. For further information, email subscriptions@bsigroup.com.

Revisions

Our British Standards and other publications are updated by amendment or revision.

We continually improve the quality of our products and services to benefit your business. If you find an inaccuracy or ambiguity within a British Standard or other BSI publication please inform the Knowledge Centre.

Useful Contacts

Customer Services

Tel: +44 345 086 9001

Email (orders): orders@bsigroup.com

Email (enquiries): cservices@bsigroup.com

Subscriptions

Tel: +44 345 086 9001

Email: subscriptions@bsigroup.com

Knowledge Centre

Tel: +44 20 8996 7004

Email: knowledgecentre@bsigroup.com

Copyright & Licensing

Tel: +44 20 8996 7070

Email: copyright@bsigroup.com

BSI Group Headquarters

389 Chiswick High Road London W4 4AL UK

Methods of test for mortar for masonry —

Part 4: Determination of consistence of fresh mortar (by plunger penetration)

The European Standard EN 1015-4:1998 has the status of a
British Standard

ICS 91.100.10

ICS 91.100.10

Descriptors: masonry work, mortars: materials, tests, penetration tests, determination, consistency

English version

Methods of test for mortar for masonry — Part 4: Determination of consistence of fresh mortar (by plunger penetration)

Méthodes d'essai des mortiers pour maçonnerie —
Partie 4: Détermination de la consistance des
mortiers frais (par pénétration du piston)

Prüfverfahren für Mörtel für Mauerwerk —
Teil 4: Bestimmung der Konsistenz von Frischmörtel
(mit Eindringgerät)

This European Standard was approved by CEN on 4 September 1998.

CEN members are bound to comply with the CEN/CENELEC Internal Regulations which stipulate the conditions for giving this European Standard the status of a national standard without any alteration. Up-to-date lists and bibliographical references concerning such national standards may be obtained on application to the Central Secretariat or to any CEN member.

This European Standard exists in three official versions (English, French, German). A version in any other language made by translation under the responsibility of a CEN member into its own language and notified to the Central Secretariat has the same status as the official versions.

CEN members are the national standards bodies of Austria, Belgium, Czech Republic, Denmark, Finland, France, Germany, Greece, Iceland, Ireland, Italy, Luxembourg, Netherlands, Norway, Portugal, Spain, Sweden, Switzerland and United Kingdom.

CEN

European Committee for Standardization
Comité Européen de Normalisation
Europäisches Komitee für Normung

Central Secretariat: rue de Stassart 36, B-1050 Brussels

Foreword

This European Standard has been prepared by Technical Committee CEN/TC 125, Masonry, the Secretariat of which is held by BSI.

This European Standard shall be given the status of a national standard, either by publication of an identical text or by endorsement, at the latest by April 1999, and conflicting national standards shall be withdrawn at the latest by September 2000.

This European Standard has been prepared under a mandate given to CEN by the European Commission and the European Free Trade Association and includes the performance requirements referred to in the Eurocode for masonry structures.

According to the CEN/CENELEC Internal Regulations, the national standards organizations of the following countries are bound to implement this European Standard: Austria, Belgium, Czech Republic, Denmark, Finland, France, Germany, Greece, Iceland, Ireland, Italy, Luxembourg, Netherlands, Norway, Portugal, Spain, Sweden, Switzerland and the United Kingdom.

Contents

	Page
Foreword	2
Introduction	3
1 Scope	3
2 Normative references	3
3 Principle	3
4 Apparatus	3
5 Sampling, preparation and storage of test samples	3
6 Procedure	3
7 Calculation and expression of results	4
8 Test report	4
Annex A (informative) Bibliography	5

Introduction

Fresh mortar is brought to a defined level of consistence as measured using the plunger penetration rod prior to the assessment of those properties which are used to characterize it.

Consistence is a measure of the fluidity and/or wetness of the fresh mortar and gives a measure of the deformability of the fresh mortar when subjected to a certain type of stress. The consistence however is not directly associated with the manner in which the fresh mortar handles when used by a craftsman.

Normally there will be a linear correlation between the plunger penetration value, measured according to this test method, and the flow value measured in accordance with prEN 1015-3, for the same type of mortar with increasing water content, but the slope will differ with different types of mortars.

1 Scope

This European Standard specifies a method for determining the consistence of freshly mixed mortars (in the following briefly referred to as fresh mortars) including those containing mineral binders and both dense and lightweight aggregates, which is by means of the plunger penetration value.

2 Normative references

This European Standard incorporates by dated or undated reference, provisions from other publications. These normative references are cited at the appropriate places in the text and the publications are listed hereafter. For dated references, subsequent amendments to or revisions of any of these publications apply to this European Standard only when incorporated in it by amendment or revision. For undated references the latest edition of the publication referred to applies.

EN 1015-2, *Methods of test for mortar for masonry — Part 2: Bulk sampling of mortars and preparation of test mortars.*

3 Principle

The plunger penetration value of a defined sample of fresh mortar is measured by the vertical penetration of a defined plunger rod which has been allowed to fall freely through a given height into the fresh mortar sample.

4 Apparatus

4.1 Plunger apparatus, conforming to Figure 1, and consisting of the following parts:

Plunger stand, with the base plate (A), frame, clamp with guide bushes (B) and fixing screw (C).

Cylindrical vessel, (D) secured centrally in a positioning recess.

Penetration rod, (E) with an upper scale and having a plastics plunger (F) of circular cross-section at the base and with a hemispherical lower end of the same diameter. The total mass of the penetration rod and plunger is $90 \text{ g} \pm 2 \text{ g}$. The penetration rod is fixed in an initial position 100 mm above the mortar surface, measured from the lower, hemispherical end of the plunger.

4.2 Tamper, consisting of a rigid, non-absorptive rod of circular cross-section, approximately 40 mm in diameter and approximately 200 mm long. The tamping face is flat and at right angles to the length of the tamper. The mass of the tamper is $0,250 \text{ kg} \pm 0,015 \text{ kg}$.

4.3 Trowel.

4.4 Palette knife.

5 Sampling, preparation and storage of test samples

The fresh mortar for this test shall have a minimum volume of 1,5 l and shall be obtained by reduction of the bulk test sample (see EN 1015-2) using a sample divider or by quartering.

Ready to use mortars (factory-made wet mortars which are retarded), and pre-batched air-lime/sand wet mortars when not gauged with hydraulic binders, shall be tested within their specified workable life.

Mortars that are made from dry constituents and water shall be mixed in accordance with EN 1015-2 unless otherwise specified.

The length of mixing period shall be measured from the moment all the constituents are introduced into the mixer.

Before testing, the batch shall be gently stirred by hand using a trowel (4.3) or palette knife (4.4) in 5 to 10 seconds to counteract any false setting etc., but without any additional mixing of the batch.

Any deviation from the mixing procedure shall be noted.

Two test samples shall be tested.

6 Procedure

Using the fixing screw [4.1(C)], secure the penetration rod [4.1(E)] in its initial position. Wipe the plunger [4.1(F)] clean with a damp cloth and dry before use.

Fill the vessel [4.1(D)] with mortar in two layers, each layer being compacted by 10 short strokes of the tamper (4.2), to ensure uniform filling of the vessel. Skim off the excess mortar with a palette knife leaving the mortar surface plane and level with the top rim of the vessel. Do not trowel further.

Place the filled vessel on the base plate [4.1(A)] and release the fixing screw, allowing the plunger to fall freely, starting from its initial position.

Determine the penetration of the plunger into the mortar by reading the scale on the lower side of the upper guide bush [4.1(B)] to the nearest mm.

7 Calculation and expression of results

Calculate the mean value of the plunger penetration from the individual values for each mortar test sample, to the nearest mm. If the two individual values deviate from their mean value by less than 10 % use this mean value as the plunger penetration value of the mortar. If the two individual plunger penetration values deviate from their mean value by more than 10 %, repeat the test using further mortar from the reduced bulk test sample (see clause 5) and if the results deviate from their mean value by less than 10 % use the mean value from the repeat test as the plunger penetration value of the mortar. If the results differ by more than 10 % consider the measurements unsatisfactory and take fresh test samples from the bulk test sample or laboratory prepared mortar and repeat the test.

8 Test report

The test report shall include the following information:

- a) the number, title and date of issue of this European Standard;
 - b) the place, date and time of taking the bulk test sample¹⁾;
- NOTE This is the sample taken from the bulk supply that is to be used for all of the tests in EN 1015.
- c) the method used for taking the bulk test sample (if known) and the name of the organization that took it;
 - d) the type, origin and designation of the mortar by reference to the relevant part of prEN 998;
 - e) preparation (mixing, casting) and storage (curing) conditions;
 - f) the date and time of preparing test samples for test (i.e. date and time of any mixing, casting, moulding, or demoulding procedure, if appropriate);
 - g) the date and time of testing;
 - h) test results (individual measurements and the plunger penetration values in mm for each test sample);
 - i) remarks, if any.

¹⁾ This information is contained on the certificate of sampling (see EN 1015-2).

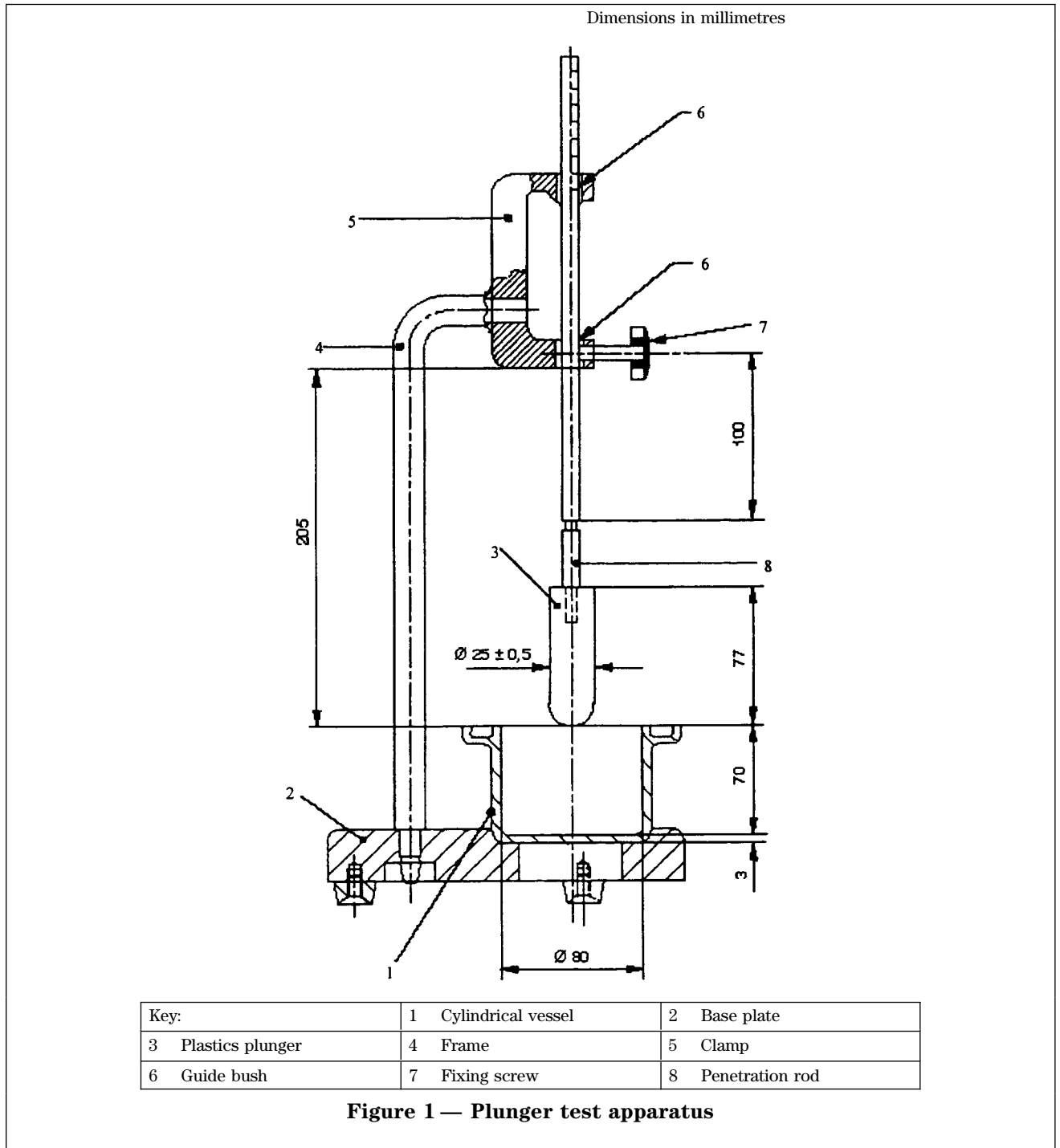

Annex A (informative)

Bibliography

The following informative reference is made in this standard:

prEN 1015-3, *Methods of test for mortar for masonry — Part 3: Determination of consistence of fresh mortar (by flow table)*.

BSI — British Standards Institution

BSI is the independent national body responsible for preparing British Standards. It presents the UK view on standards in Europe and at the international level. It is incorporated by Royal Charter.

Revisions

British Standards are updated by amendment or revision. Users of British Standards should make sure that they possess the latest amendments or editions.

It is the constant aim of BSI to improve the quality of our products and services. We would be grateful if anyone finding an inaccuracy or ambiguity while using this British Standard would inform the Secretary of the technical committee responsible, the identity of which can be found on the inside front cover. Tel: 020 8996 9000. Fax: 020 8996 7400.

BSI offers members an individual updating service called PLUS which ensures that subscribers automatically receive the latest editions of standards.

Buying standards

Orders for all BSI, international and foreign standards publications should be addressed to Customer Services. Tel: 020 8996 9001. Fax: 020 8996 7001.

In response to orders for international standards, it is BSI policy to supply the BSI implementation of those that have been published as British Standards, unless otherwise requested.

Information on standards

BSI provides a wide range of information on national, European and international standards through its Library and its Technical Help to Exporters Service. Various BSI electronic information services are also available which give details on all its products and services. Contact the Information Centre. Tel: 020 8996 7111. Fax: 020 8996 7048.

Subscribing members of BSI are kept up to date with standards developments and receive substantial discounts on the purchase price of standards. For details of these and other benefits contact Membership Administration. Tel: 020 8996 7002. Fax: 020 8996 7001.

Copyright

Copyright subsists in all BSI publications. BSI also holds the copyright, in the UK, of the publications of the international standardization bodies. Except as permitted under the Copyright, Designs and Patents Act 1988 no extract may be reproduced, stored in a retrieval system or transmitted in any form or by any means – electronic, photocopying, recording or otherwise – without prior written permission from BSI.

This does not preclude the free use, in the course of implementing the standard, of necessary details such as symbols, and size, type or grade designations. If these details are to be used for any other purpose than implementation then the prior written permission of BSI must be obtained.

If permission is granted, the terms may include royalty payments or a licensing agreement. Details and advice can be obtained from the Copyright Manager. Tel: 020 8996 7070.