



ISO 9001



ISO 14001



OHSAS 18001

LEADING THE RECYCLING ECONOMY,  
INNOVATIVE ENERGY-SAVING EMISSION REDUCTION!



Oldlang Smart Electrical



# Arc Fault Detection Device (AFDD)

MCB+RCCB+AFDD  
230VAC; 1~63A; B, C  
10, 30mA; AC,A

GB/T 31143  
GB 14287.4  
IEC/EN 62606



Gold Supplier Trade Assurance  
[Http://Smartelectrical.en.alibaba.com](http://Smartelectrical.en.alibaba.com)  
Alibaba.com Verified TrustPass



www.Oldlang.cn Oldlang\_sale@163.com



Electrical Fire Prevention

# Arc Fault Detection Device (AFDD)



Innovative Energy-Saving Emission Reduction  
Leading The Recycling Economy

www.Oldlang.cn  
Oldlang\_sale@163.com

## About Oldlang Smart Electrical

Oldlang Smart Technology Co.,Ltd. is a modern technology enterprise, committed to innovating energy conservation and emission reduction and leading the circular economy. The products focus on the original, low carbon, energy saving, collecting data, remote control and other functions are the characteristics of Oldlang's Smart electrical products. To enable users to use energy safely, reliably and efficiently is the value idea of Oldlang Smart Electrical. Therefore, the intelligent energy management is not only the inevitable development of the times, but also the direction of the development of the intelligent electrical of Oldlang's. Oldlang Smart Electrical provide wisdom into the city, the intelligent household practical products, improve people's life, improve the earth's environment, insist on sustainable development has always been the belief of Oldlang Smart Electrical.

In Oldlang smart electrical, we are always advocating:

INNOVATIVE ENERGY-SAVING EMISSION REDUCTION  LEADING THE RECYCLING ECONOMY!





Electrical Fire Prevention

# Arc Fault Detection Device (AFDD)

## CE Certificate

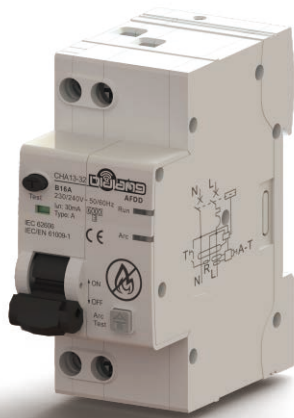

## VDA14-63 arc fault detection device with integrated MCB (2P)

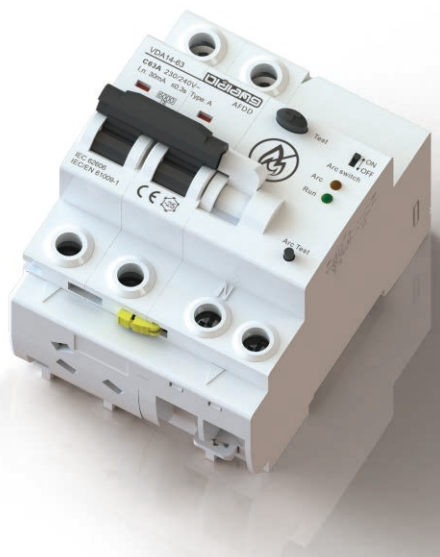

■ Each year all over Europe, over two million fires start due to faults in the electrical installation and these often occur as a result of dangerous arc faults.

■ An AFDD (Arc Fault Detection Device) according to the product standard "IEC 62606 - General requirements for Arc Fault Detection Devices" is a device intended to mitigate the effects of arcing faults by disconnecting the circuit when an arc fault is detected.

■ AFDD are the new 1P+N arc fault detection devices with integrated miniature circuit breaker (MCB) in 10kA breaking capacity respectively: in only three modules width, these devices provide protection against overcurrents and arc faults.

■ AFDD are the new 2P arc fault detection devices with integrated miniature circuit breaker (MCB) in 10kA breaking capacity respectively: in only four modules width, these devices provide protection against overcurrents and arc faults.

■ Combined with a Residual Current Circuit Breaker (RCCB) as upstream device, the CHA13-63 and VDA14-63 series provides the best solution for complete protection in the switchboard, for people, buildings, and irreplaceable goods.

■ CHA13-32 and CHA13-32G are the new 1P+N arc fault detection devices with Residual Current Circuit Breaker with Overload protection (RCBO) in 6kA breaking capacity respectively: in only three modules width, these devices provide protection against overcurrents and arc faults.



2 million fires  
In Europe per year



80 %  
of these fires occurred in private households



20 %  
of these fires in the commercial sector



33 %  
of these fires occur due to faults in the electrical installation



Electrical Fire Prevention

# Arc Fault Detection Device (AFDD)

The majority of fires in buildings are caused by faults in the electrical installation. These fires are mainly caused by dangerous arc faults.

**The solution: AFDD.**

■ AFDD provides maximum safety in all buildings, thus protecting people and valuable assets. By early detecting arc faults and disconnecting the affected circuit the AFDD with integrated MCB or RCBO offers reliable and complete protection in any type of building.

## ■ Recommendation for any room

The use of the AFDD is additionally recommended in any rooms with sleeping facilities in private apartments, houses, hospitals (does not apply in medically used areas) and hotels. This also includes places with a pre-disseminating structure, such as the chimney effect in high-rise buildings or final circuits with high connected load, e.g. dishwashers, washing machines or dryers.

## ■ Safety in many building types

According to the standard IEC 60364-4-42, an arc fault detection device is strongly recommended in particular applications, as per example:

- Sleeping and common rooms
  - in nurseries
  - in senior and care homes
  - in equipment for disabled persons
- Places and rooms with existing fire risks and flammable materials, such as for example in production facilities, barns, carpenter workshops, paper manufacturing plants or printing shops where the fire risk is high
- Places and rooms with prevalently flammable building materials like wood houses, flammable buildings or forced ventilation systems
- Places and rooms with irreplaceable goods (cultural assets), such as those in museums, libraries, galleries, archives or architectural monuments.





# Arc Fault Detection Device (AFDD)

## Early detection for extended protection against fires

AFDD closes the protection gap against arc faults

■ The arc fault detection device (AFDD) detects series arc faults (current is flowing within one conductor of the Pnal circuit), parallel arc faults (current is flowing between active conductors in parallel with the load of the circuit) and earth arc faults (current is flowing from active conductor to the earth).

■ Disruptions in the electrical installation Serial arc faults occur when a conductor is disrupted, parallel arc faults in the case of contact between phase and neutral conductors or in the case of contact between phase and protective conductors.

### ■ The most frequent causes of the development of arc faults are:

- Damaged insulation, e.g. by screws or nails
- Trapped cables in doors and windows
- Incorrect installation
- Cable breakage due to e.g. bend radii which are too narrow and mounting clips which are too tight
- UV radiation and rodent damage to cables in the outdoor areas
- Loose contacts and connections, for example in poorly installed switches/outlets or multiple sockets
- Snapped plugs and cables, e.g. due to carelessly moved furniture

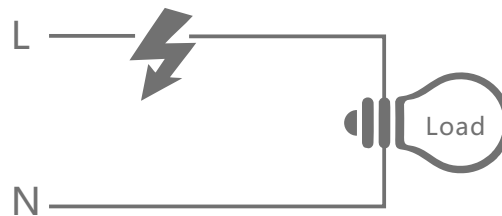
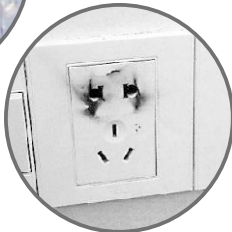
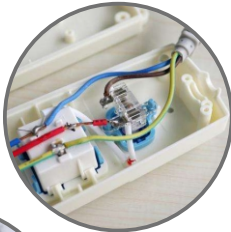

Series Arc fault  $\geq 5A$

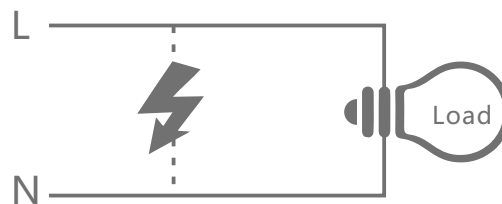

Parallel arc fault  $\geq 75A$

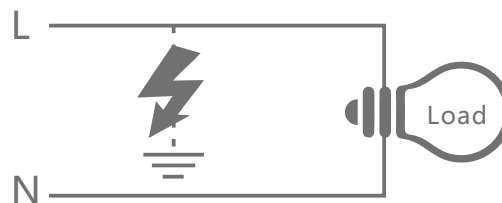

Earth arc fault



Electrical Fire Prevention

# CHA13 (AFDD) Arc Fault Detection Device

### Guaranteed security readability over time.

Contact position indicator (CPI) to always know the status of the contacts (red: closed; green: open). Independent from the toggle position.

### Easy to install

Twin terminals for separate feeding with busbar and cables. Connection possible both from top and bottom side.

### Handle position for troubleshooting

Handle position troubleshooting indicator to monitor the operation of the AFDD and give indication of the cause of the trip.



Normal

Short circuit or overload protection

Fault arc protection

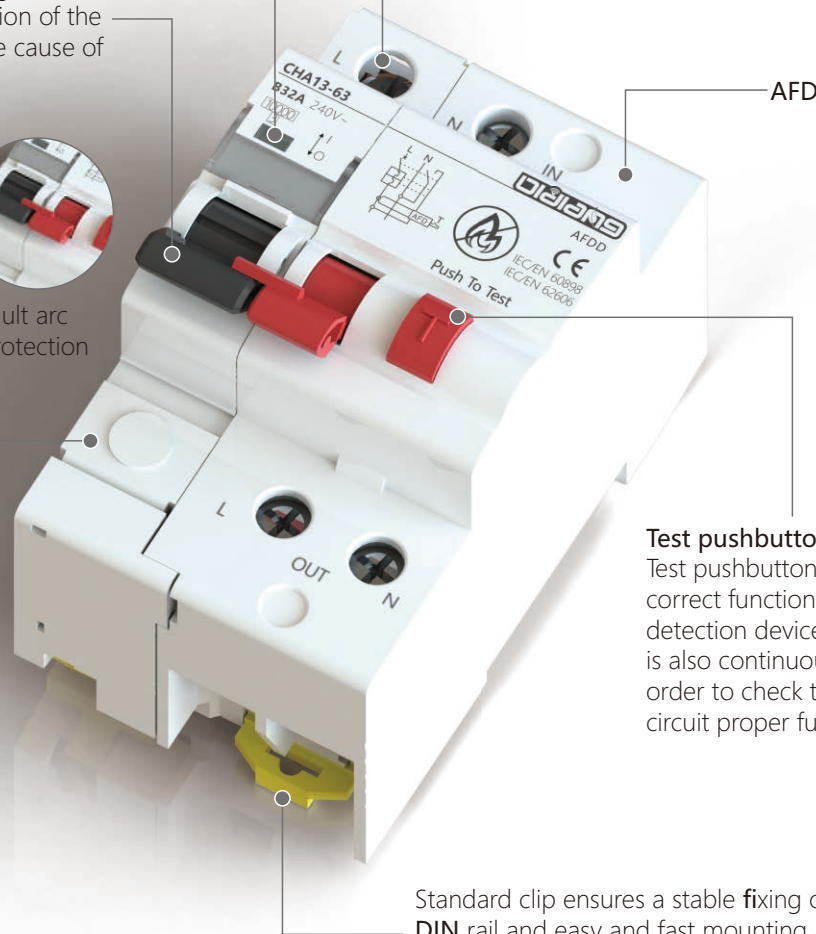

AFD

### Test pushbutton and self test

Test pushbutton to verify the correct functioning of the arc fault detection device. Internal self test is also continuously running in order to check the arc detection circuit proper functioning.

Standard clip ensures a stable fixing on DIN rail and easy and fast mounting and dismantling operations

MCB 1P(18mm): CHA13-63  
MCB 2P(36mm): CHA13-63/2  
RCBO 1P+N(18mm): CHA13-32G



MCB 1P



MCB 2P

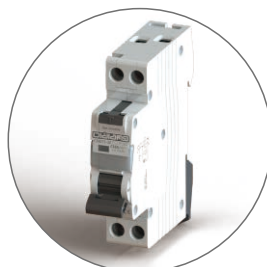

RCBO 1P+N



Electrical Fire Prevention

# CHA13 (AFDD) Arc Fault Detection Device

CHA13-63 (AFDD)  
Arc Fault Detection Device

MCB(1P,18mm) +AFD(36mm)

IEC/EN 60898  
IEC/EN 62606

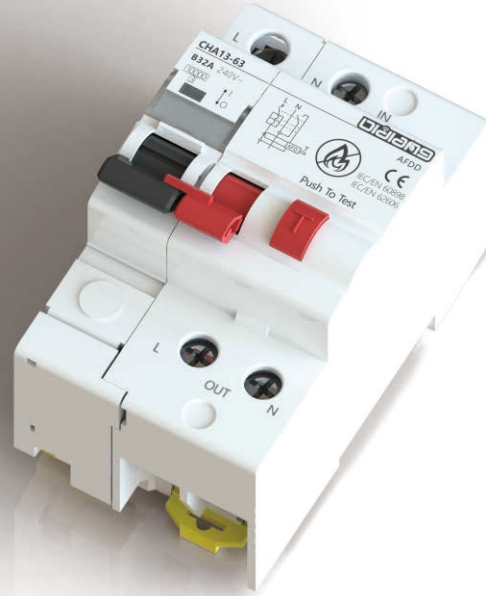
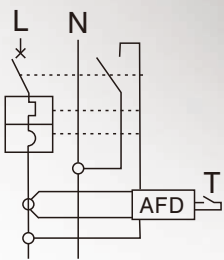

## Technical data

Main characteristics						
Tripping time/arc current value with $U_n = 230 \text{ V AC}$ (to IEC/EN 62606)	Arc current	3A	6A	13A	20A	25A
	Max. operating time	1s	0.5s	0.25s	0.15s	0.14s
Overtoltage tripping time (neutral conductor break)		400 V AC, 200 ms				
Insulation voltage ( $U_i$ )		400 V AC				
Degree of pollution		2				
Rated impulse withstand voltage ( $U_{imp}$ )		4kV				
Rated making and breaking capacity ( $I_m$ )		500A				
Overtoltage category		III				
Characteristic	Max. rating	32A				
	Curve	B or C				
	Residual operating current ( $I_{r,n}$ )					
	Type					
	Boost voltage	Electronic				
	Rated breaking capacity ( $I_{cn}$ )	10,000A				
Additional characteristics						
Degree of protection	Device alone	IP20				
	Device in a modular enclosure	IP40 Insulation class II				
Endurance (O-C)	Electrical	≤20 A	20,000 cycles			
		25 A	10,000 cycles			
	Mechanical	20,000 cycles				
Operating temperature		-25°C to +60°C				
Storage temperature		-45°C to +85°C				
Tropicalization (to IEC/EN 62606)		Severity B (to IEC 60068-2-30) during 28 days				



Electrical Fire Prevention

# CHA13 (AFDD) Arc Fault Detection Device

CHA13-63/2 (AFDD)  
Arc Fault Detection Device

MCB(2P,36mm) +AFD(36mm)

IEC/EN 60898  
IEC/EN 62606

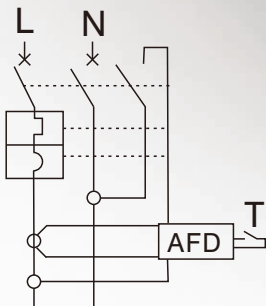

## Technical data

Main characteristics						
Tripping time/arc current value with $U_n = 230 \text{ V AC}$ (to IEC/EN 62606)	Arc current	3A	6A	13A	20A	25A
	Max. operating time	1s	0.5s	0.25s	0.15s	0.14s
Oversvoltage tripping time (neutral conductor break)		400 V AC, 200 ms				
Insulation voltage ( $U_i$ )		400 V AC				
Degree of pollution		2				
Rated impulse withstand voltage ( $U_{imp}$ )		4kV				
Rated making and breaking capacity ( $I_m$ )		500A				
Oversvoltage category		III				
Characteristic	Max. rating	32A				
	Curve	B or C				
	Residual operating current ( $I_{\Delta n}$ )					
	Type					
	Boost voltage	Electronic				
	Rated breaking capacity ( $I_{cn}$ )	10,000A				
Additional characteristics						
Degree of protection	Device alone	IP20				
	Device in a modular enclosure	IP40 Insulation class II				
Endurance (O-C)	Electrical	$\leq 20 \text{ A}$	20,000 cycles			
		25 A	10,000 cycles			
	Mechanical	20,000 cycles				
Operating temperature		-25°C to +60°C				
Storage temperature		-45°C to +85°C				
Tropicalization (to IEC/EN 62606)		Severity B (to IEC 60068-2-30) during 28 days				



Electrical Fire Prevention

# CHA13 (AFDD) Arc Fault Detection Device

CHA13-32G(AFDD)  
Arc Fault Detection Device

RCBO(1P+N,18mm) +AFD(36mm)

IEC/EN 61009  
IEC/EN 62606

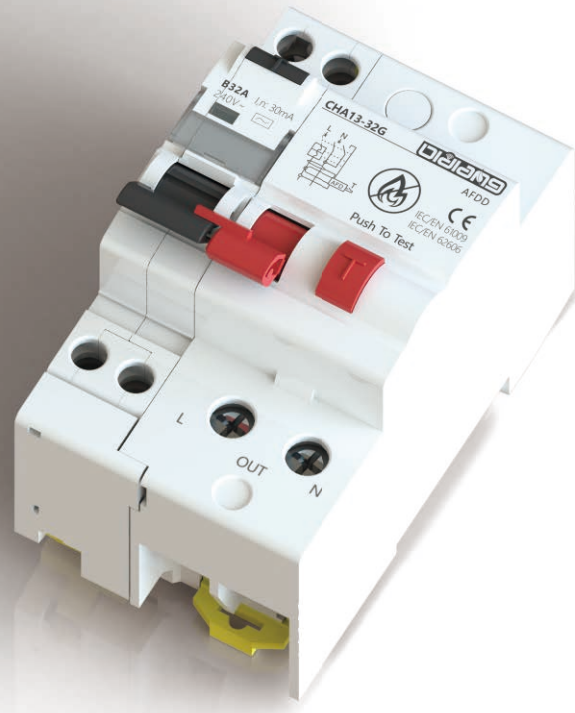
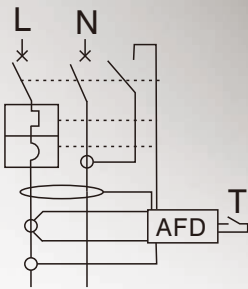

## Technical data

Main characteristics						
Tripping time/arc current value with $U_n = 230 \text{ V AC}$ (to IEC/EN 62606)	Arc current	3A	6A	13A	20A	25A
	Max. operating time	1s	0.5s	0.25s	0.15s	0.14s
Overtoltage tripping time (neutral conductor break)		400 V AC, 200 ms				
Insulation voltage ( $U_i$ )		400 V AC				
Degree of pollution		2				
Rated impulse withstand voltage ( $U_{imp}$ )		4kV				
Rated making and breaking capacity ( $I_m$ )		500A				
Overtoltage category		III				
Characteristic	Max. rating	32A				
	Curve	B or C				
	Residual operating current ( $I_{\Delta n}$ )	10, 30mA				
	Type	AC, A				
	Boost voltage	Electronic				
	Rated breaking capacity ( $I_{cn}$ )	6,000A				
Additional characteristics						
Degree of protection	Device alone	IP20				
	Device in a modular enclosure	IP40 Insulation class II				
Endurance (O-C)	Electrical	$\leq 20 \text{ A}$	20,000 cycles			
		25 A	10,000 cycles			
	Mechanical	20,000 cycles				
Operating temperature		-25°C to +60°C				
Storage temperature		-45°C to +85°C				
Tropicalization (to IEC/EN 62606)		Severity B (to IEC 60068-2-30) during 28 days				



# CHA13-32 (AFDD) Arc Fault Detection Device



CHA13-32 is an arc fault detection device which aims to reduce the risk of electrical fire.

By continuously analyzing a large number of electrical parameters, it detects the appearance of electric arcs that are responsible for starting fires. It isolates the circuit concerned which reduce flame appearance occurrence.

The European installation standard IEC 60364-4-42, recommends the use of AFDD to protect against arc fault in Pnal circuit:

- in locations with sleeping accommodations (e.g., hotels, nursing homes, bedrooms in homes)
- in locations with risks of fire due to high quantities of flammable materials (e.g., barns, wood-working shops, stores of combustible materials)
- in locations with combustible constructional materials (e.g., wooden buildings)
- in Pre propagating structures (e.g. high rise buildings)
- in locations where irreplaceable goods are housed (e.g., museums).

More specifically, the installation of CHA13-32 is highly recommended to protect circuits with highest risk of Pre, such as:

- protruding cables (risk of knocks)
- outside cables (greater risk of deterioration)
- unprotected cables in secluded areas (like storage rooms)
- aging, deteriorating wiring or wiring for which the connection boxes are inaccessible.

CHA13-32 itself has the function of MCB+RCCB+AFDD.

GB/T 31143 (China)  
GB 14287.4 (China)  
IEC/EN 62606 (Europe)

General requirements for arc detection devices.

■ CHA13-32 monitors electric arcs that occur in cables and connections and cause a fire.

These arcs are the result of localised cable deterioration or loose connections

■ It is used for three types of situations that can result in a fire:

□ parallel arc: insulation problems between two live conductors that cause a resistive short-circuit, too weak to be detected by a circuit breaker and with no earth leakage that would be detected by an earth-leakage protection device,

□ series arc: a damaged conductor or connection that causes part of the current to pass into its carbonised insulation due to a local rise in temperature,

□ overheating of electronic components in loads, when exposed to an overvoltage for several seconds.

■ It combines the following functions:

- protection against Pre hazards by detection of abnormal electric arcs,
- protection against load Pre hazards due to slow overvoltages,
- circuit opening and positive break indication (green strip),
- fire hazard tripping indication via the front panel indicator,
- device self-diagnostics via the test button.

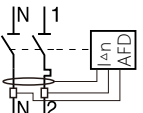

■ CHA13-32 is a MCB + RCBO + AFDD, max. 32A, it protects Phase-Neutral or Phase-Phase circuits, in full coordination under short-circuit conditions up to a rated breaking capacity (Icn) of 6,000 A.

## Operating frequency

CHA13-32			
Arc Fault Detection Device (AFDD) to IEC/EN 62606	Model	Width in 9 mm modules	
1P+N			
	Rating 32A (In)	CHA13-32	4
Operating voltage	230 V AC		
Operating frequency	50 Hz		

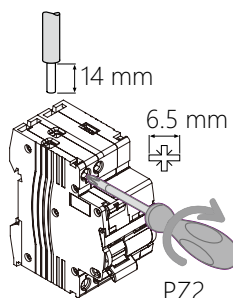
## Connection



Tightening torque	Copper cables only	
	Rigid	Flexible or with ferrule
2 N.m		
	1X1 to 16mm <sup>2</sup> 2X1 to 2.5mm <sup>2</sup>	1X1 to 10mm <sup>2</sup> 2X1 to 2.5mm <sup>2</sup>



Electrical Fire Prevention

# CHA13-32 (AFDD) Arc Fault Detection Device

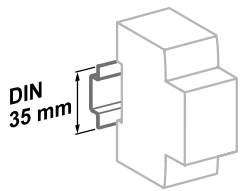
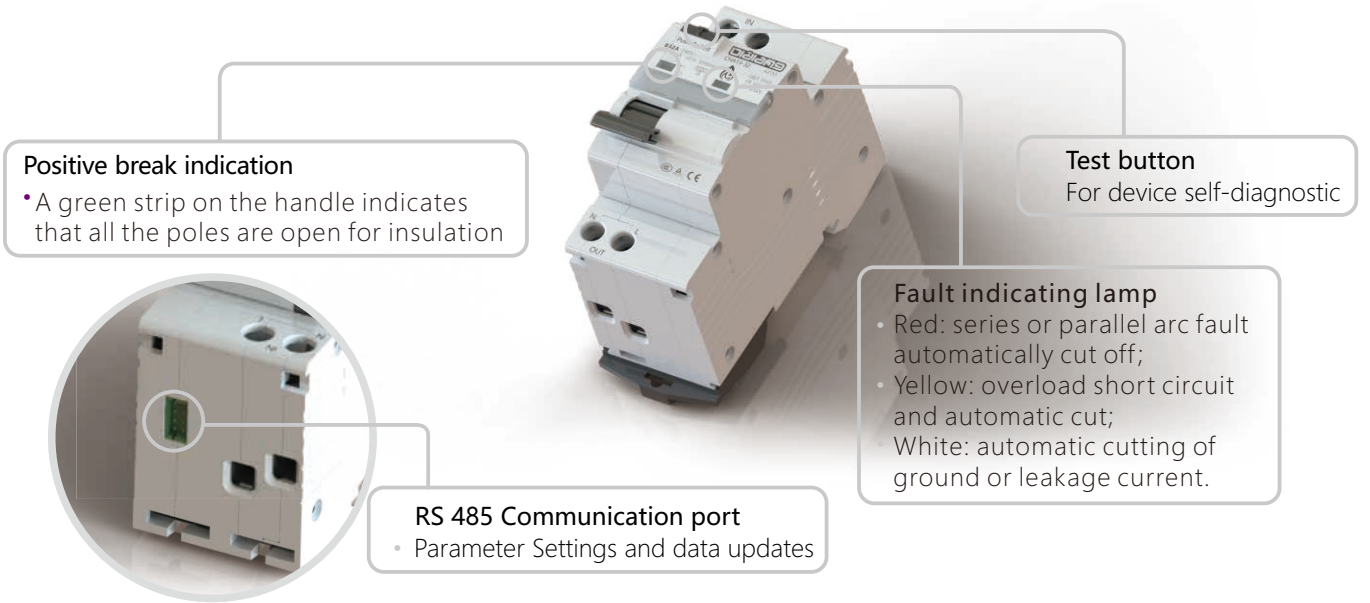

Clip on DIN rail 35 mm.

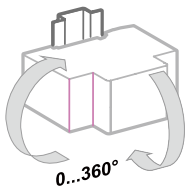

Indifferent position of installation.

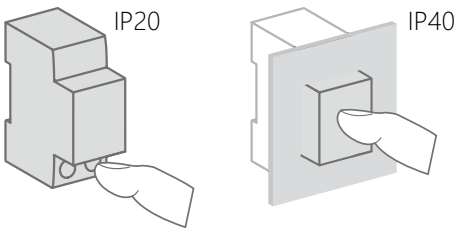

## Technical data

Main characteristics						
Tripping time/arc current value with $U_n = 230\text{ V AC}$ (to IEC/EN 62606)	Arc current	3A	6A	13A	20A	25A
	Max. operating time	1s	0.5s	0.25s	0.15s	0.14s
Oversvoltage tripping time (neutral conductor break)		400 V AC, 200 ms				
Insulation voltage ( $U_i$ )		400 V AC				
Degree of pollution		2				
Rated impulse withstand voltage ( $U_{imp}$ )		4kV				
Rated making and breaking capacity ( $I_m$ )		500A				
Oversvoltage category		III				
Characteristic of RCBO	Max. rating	32A				
	Curve	B or C				
	Residual operating current ( $I_{\Delta n}$ )	10, 30mA				
	Type	AC, A				
	Boost voltage	Electronic				
	Rated breaking capacity ( $I_{cn}$ )	6,000A				
Additional characteristics						
Degree of protection	Device alone	IP20				
	Device in a modular enclosure	IP40 Insulation class II				
Endurance (O-C)	Electrical	$\leq 20\text{ A}$	20,000 cycles			
		25 A	10,000 cycles			
	Mechanical	20,000 cycles				
Operating temperature		-25°C to +60°C				
Storage temperature		-45°C to +85°C				
Tropicalization (to IEC/EN 62606)		Severity B (to IEC 60068-2-30) during 28 days				



Electrical Fire Prevention

# CHA13-32 (AFDD) Arc Fault Detection Device

## Weight (g)

Arc fault detection device	
Type	CHA13-32
1P+N	200

## Outline Size And Connection Diagram (mm)

Arc fault detection device	
Undimensioned tolerance	Mounting hole size tolerance
< 1mm: ±0.2mm	±0.4mm
1~5mm: ±0.3mm	
> 5mm: ±0.5mm	

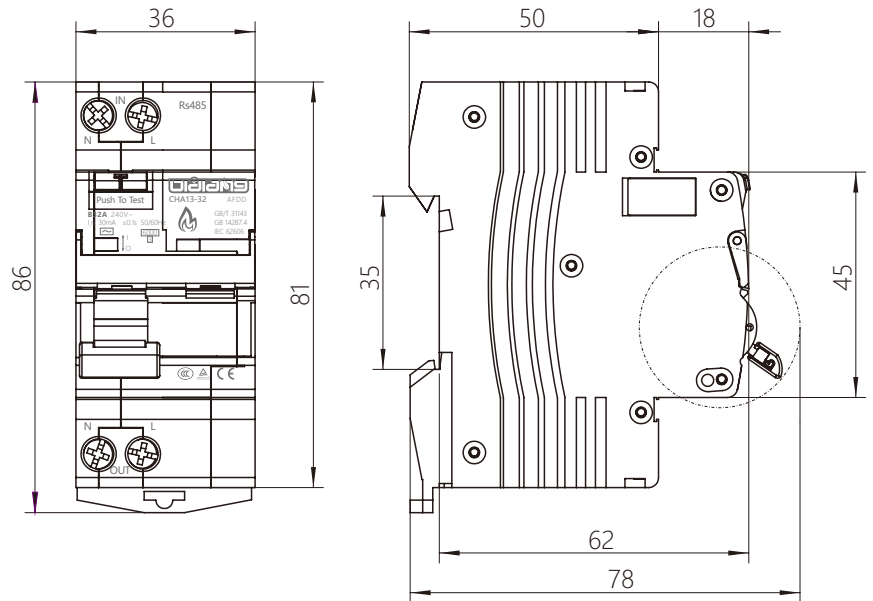
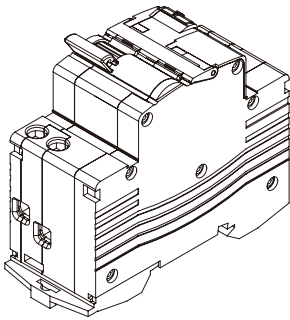



Electrical Fire Prevention

# VDA14-63 (AFDD) Arc Fault Detection Device

**Guaranteed security readability over time.**  
Contact position indicator (CPI) to always know the status of the contacts (red: closed; green: open).  
Independent from the toggle position.

**Easy to install**  
Twin terminals for separate feeding with busbar and cables.  
Connection possible both from top and bottom side.

**Handle position for troubleshooting**  
Handle position troubleshooting indicator to monitor the operation of the AFDD and give indication of the cause of the trip.



Normal

Short circuit or overload protection

Fault arc protection

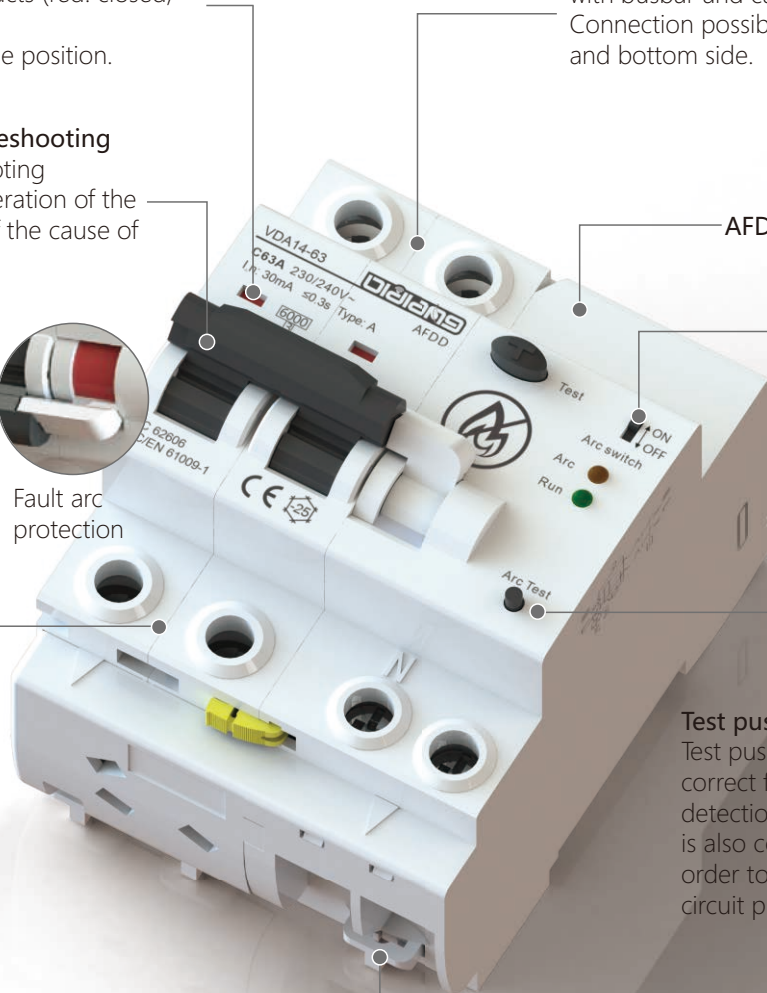

**Test pushbutton and self test**  
Test pushbutton to verify the correct functioning of the arc fault detection device. Internal self test is also continuously running in order to check the arc detection circuit proper functioning.

- MCB 1P(18mm): CHA13-63
- MCB 2P(36mm): CHA13-63/2
- RCBO 1P+N(18mm): CHA13-32G



MCB 1P



MCB 2P

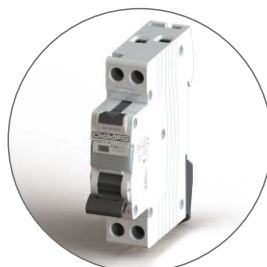

RCBO 1P+N



Electrical Fire Prevention

# VDA14-63 (AFDD) Arc Fault Detection Device

VDA14-63/2 (AFDD)  
Arc Fault Detection Device

MCB(2P,36mm) +AFD(36mm)

IEC/EN 60898  
IEC/EN 62606

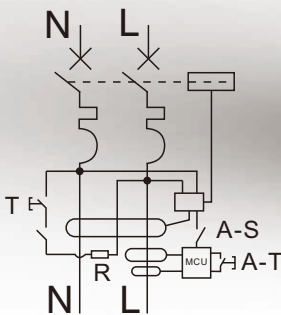

## Technical data

Main characteristics						
Tripping time/arc current value with $U_n = 230 \text{ V AC}$ (to IEC/EN 62606)	Arc current	3A	6A	13A	20A	25A
	Max. operating time	1s	0.5s	0.25s	0.15s	0.14s
Overvoltage tripping time (neutral conductor break)		400 V AC, 200 ms				
Insulation voltage ( $U_i$ )		400 V AC				
Degree of pollution		2				
Rated impulse withstand voltage ( $U_{imp}$ )		4kV				
Rated making and breaking capacity ( $I_m$ )		500A				
Overvoltage category		III				
Characteristic	Max. rating	63A				
	Curve	B or C				
	Residual operating current ( $I_{\Delta n}$ )					
	Type					
	Boost voltage	Electronic				
	Rated breaking capacity ( $I_{cn}$ )	10,000A				
Additional characteristics						
Degree of protection	Device alone	IP20				
	Device in a modular enclosure	IP40 Insulation class II				
Endurance (O-C)	Electrical	$\leq 20 \text{ A}$	20,000 cycles			
		25 A	10,000 cycles			
	Mechanical	20,000 cycles				
Operating temperature		-25°C to +60°C				
Storage temperature		-45°C to +85°C				
Tropicalization (to IEC/EN 62606)		Severity B (to IEC 60068-2-30) during 28 days				



Electrical Fire Prevention

# VDA14-63 (AFDD) Arc Fault Detection Device

## Weight (g)

Arc fault detection device	
Type	CHA13-32
1P+N	200

## Outline Size And Connection Diagram (mm)

Arc fault detection device	
Undimensioned tolerance	Mounting hole size tolerance
< 1mm: $\pm 0.2\text{mm}$	$\pm 0.4\text{mm}$
1~5mm: $\pm 0.3\text{mm}$	
> 5mm: $\pm 0.5\text{mm}$	

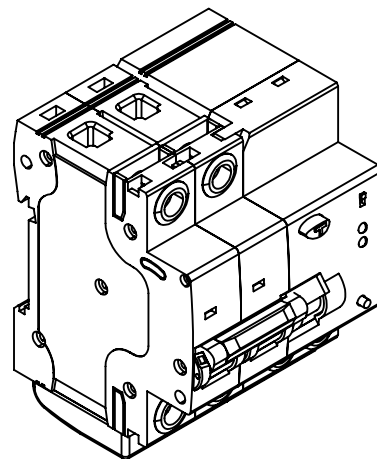
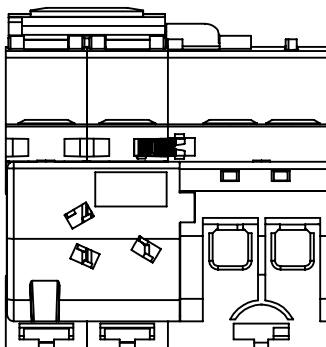
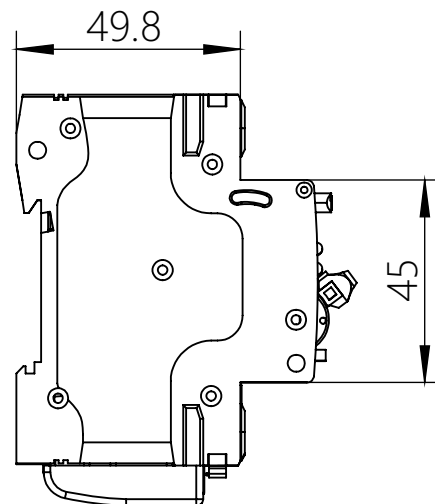
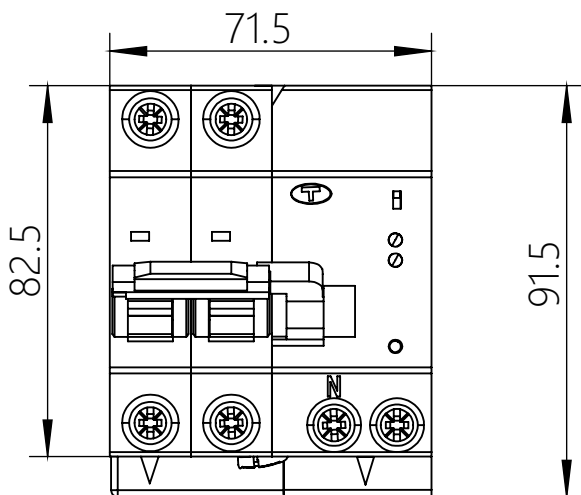



# VDA14-32 (AFDD) Arc Fault Detection Device

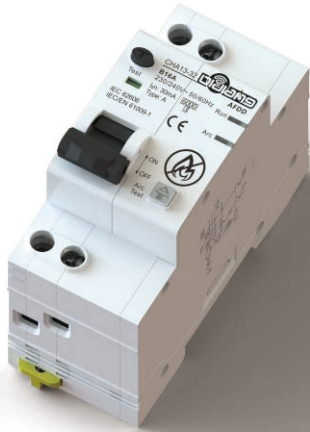

VDA14-32 is an arc fault detection device which aims to reduce the risk of electrical fire.

By continuously analyzing a large number of electrical parameters, it detects the appearance of electric arcs that are responsible for starting fires. It isolates the circuit concerned which reduce flame appearance occurrence.

The European installation standard IEC 60364-4-42, recommends the use of AFDD to protect against arc fault in Pnal circuit:

- in locations with sleeping accommodations (e.g., hotels, nursing homes, bedrooms in homes)
- in locations with risks of fire due to high quantities of flammable materials (e.g., barns, wood-working shops, stores of combustible materials)
- in locations with combustible constructional materials (e.g., wooden buildings)
- in Pre propagating structures (e.g. high rise buildings)
- in locations where irreplaceable goods are housed (e.g., museums).

More specifically, the installation of VDA14-32 is highly recommended to protect circuits with highest risk of Pre, such as:

- protruding cables (risk of knocks)
- outside cables (greater risk of deterioration)
- unprotected cables in secluded areas (like storage rooms)
- aging, deteriorating wiring or wiring for which the connection boxes are inaccessible.

VDA14-32 itself has the function of MCB+RCCB+AFDD.

GB/T 31143 (China)  
GB 14287.4 (China)  
IEC/EN 62606 (Europe)

General requirements for arc detection devices.

■ VDA14-32 monitors electric arcs that occur in cables and connections and cause a fire.

These arcs are the result of localised cable deterioration or loose connections

■ It is used for three types of situations that can result in a fire:

□ parallel arc: insulation problems between two live conductors that cause a resistive short-circuit, too weak to be detected by a circuit breaker and with no earth leakage that would be detected by an earth-leakage protection device,

□ series arc: a damaged conductor or connection that causes part of the current to pass into its carbonised insulation due to a local rise in temperature,

□ overheating of electronic components in loads, when exposed to an overvoltage for several seconds.

■ It combines the following functions:

- protection against Pre hazards by detection of abnormal electric arcs,
- protection against load Pre hazards due to slow overvoltages,
- circuit opening and positive break indication (green strip),
- fire hazard tripping indication via the front panel indicator,
- device self-diagnostics via the test button.

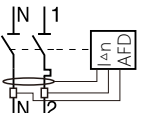

■ VDA14-32 is a MCB + RCBO + AFDD, max. 32A, it protects Phase-Neutral or Phase-Phase circuits, in full coordination under short-circuit conditions up to a rated breaking capacity (Icn) of 6,000 A.

## Operating frequency

VDA14-32			
Arc Fault Detection Device (AFDD) to IEC/EN 62606	Model	Width in 9 mm modules	
1P+N			
	Rating 32A (In)	VDA14-32	4
Operating voltage	230 V AC		
Operating frequency	50 Hz		

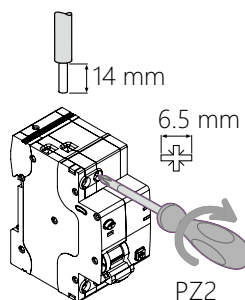
## Connection



Tightening torque	Copper cables only	
	Rigid	Flexible or with ferrule
2 N.m		
	1X1 to 16mm <sup>2</sup> 2X1 to 2.5mm <sup>2</sup>	1X1 to 10mm <sup>2</sup> 2X1 to 2.5mm <sup>2</sup>



# VDA14-32 (AFDD) Arc Fault Detection Device

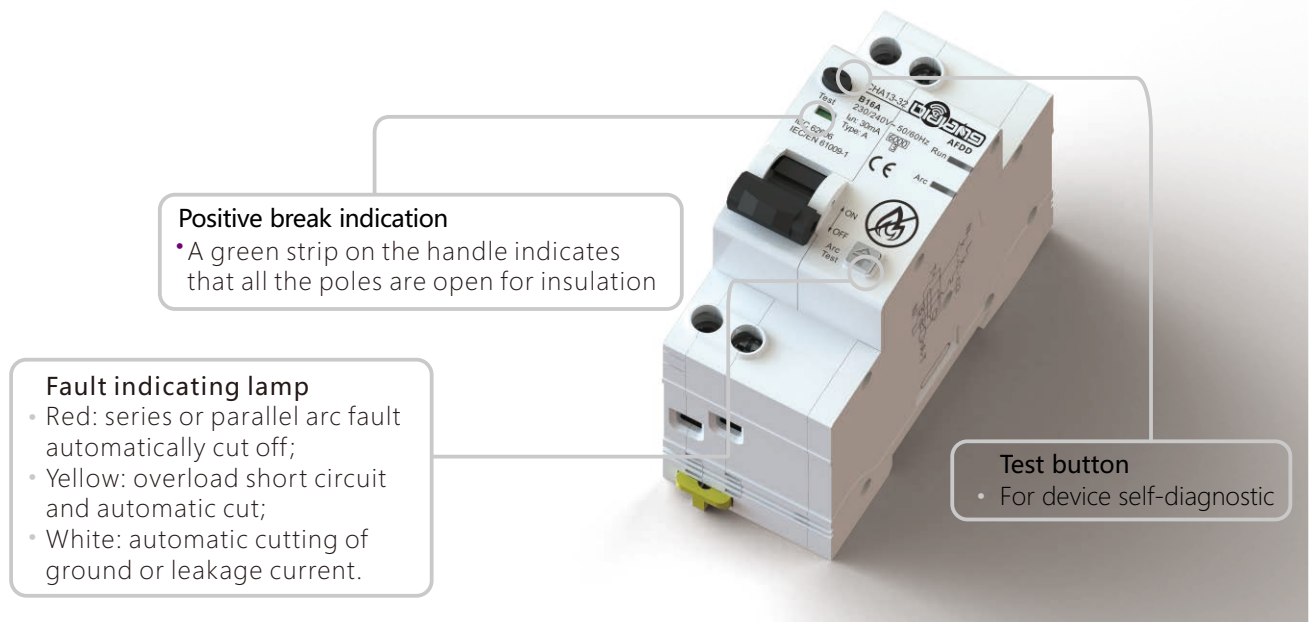

**Positive break indication**

- A green strip on the handle indicates that all the poles are open for insulation

**Fault indicating lamp**

- Red: series or parallel arc fault automatically cut off;
- Yellow: overload short circuit and automatic cut;
- White: automatic cutting of ground or leakage current.

**Test button**

- For device self-diagnostic

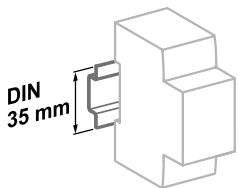

Clip on DIN rail 35 mm.

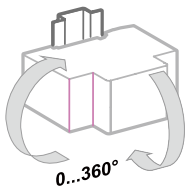

Indifferent position of installation.

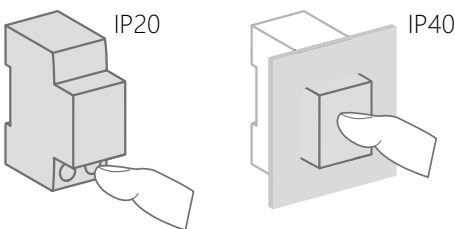

## Technical data

Main characteristics						
Tripping time/arc current value with $U_n = 230\text{ V AC}$ (to IEC/EN 62606)	Arc current	3A	6A	13A	20A	25A
	Max. operating time	1s	0.5s	0.25s	0.15s	0.14s
Oversvoltage tripping time (neutral conductor break)		400 V AC, 200 ms				
Insulation voltage ( $U_i$ )		400 V AC				
Degree of pollution		2				
Rated impulse withstand voltage ( $U_{imp}$ )		4kV				
Rated making and breaking capacity ( $I_m$ )		500A				
Oversvoltage category		III				
Characteristic of RCBO	Max. rating	32A				
	Curve	B or C				
	Residual operating current ( $I_{\Delta n}$ )	10, 30mA				
	Type	AC, A				
	Boost voltage	Electronic				
	Rated breaking capacity ( $I_{cn}$ )	6,000A				
Additional characteristics						
Degree of protection	Device alone	IP20				
	Device in a modular enclosure	IP40 Insulation class II				
Endurance (O-C)	Electrical	$\leq 20\text{ A}$	20,000 cycles			
		25 A	10,000 cycles			
	Mechanical	20,000 cycles				
Operating temperature		-25°C to +60°C				
Storage temperature		-45°C to +85°C				
Tropicalization (to IEC/EN 62606)		Severity B (to IEC 60068-2-30) during 28 days				



# VDA14-32 (AFDD) Arc Fault Detection Device

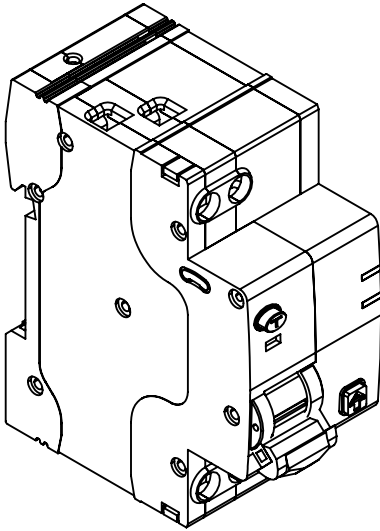

## Weight (g)

Arc fault detection device	
Type	VDA14-32
1P+N	200

## Outline Size And Connection Diagram (mm)

Arc fault detection device	
Undimensioned tolerance	Mounting hole size tolerance
< 1mm:±0.2mm	±0.4mm
1~5mm:±0.3mm	
> 5mm:±0.5mm	

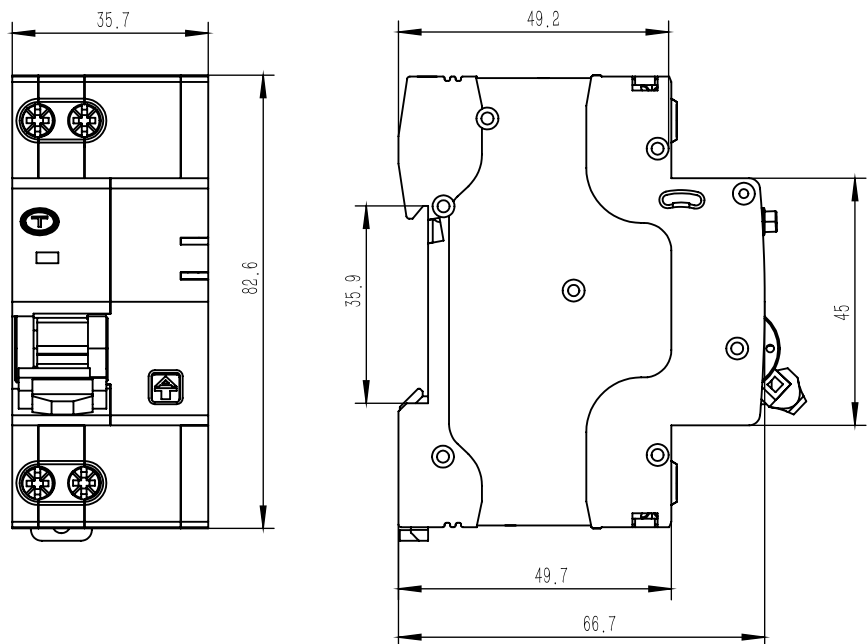



SAVE ON ENERGY, STARTS FROM ME !



TrustPass Gold Supplier Trade Assurance



**Gold Supplier** Trade Assurance  
[Http://Smartelectrical.en.Alibaba.com](http://Smartelectrical.en.Alibaba.com)  
**Alibaba.com** **Verified** TrustPass



[www.Oldlang.cn](http://www.Oldlang.cn) [Oldlang\\_sale@163.com](mailto:Oldlang_sale@163.com)